

Conveyor & Elevator Belts

High Performance Belting for Tough Applications



GOODYEAR
RUBBER PRODUCTS, INC.

📞 727-342-5088

You can also email us at
GRP@goodyearrubberproducts.com

High Quality Belting

GRT Rubber Technologies offers the most extensive line of sheet rubber and conveyor belt products in the industry. Our top quality products are made with pride at our state of the art facility in Paragould, Arkansas. We manufacture our modern belting products efficiently and cost effectively, to provide you with years of high performance bulk haulage at the lowest cost per ton.

The success of GRT Rubber Technologies is founded on experience, innovation, cutting-edge technology and dedication to quality. Our technical lab is one of the industry's most advanced; we rigorously test the physical, chemical and component properties of raw materials and finished products. Our computer-controlled manufacturing equipment ensures the tightest possible gauge tolerances and highest quality control. Technology combined with extensive training and experience means our quality is guaranteed.

Our experienced engineering and field support staff are available to help you decide which products are best for your job requirements. We have a wide range of made-to-order capabilities so we can customize a product to meet your special needs.



Contents

Conveyor Belt Components.....	1
Fabrics	2
Cover Compounds	2
Product Overview	4
FlexKing® Belts	5
FlexKing® Elevator Belts	8
DuraKing® Belts	9
TechFlex® Conveyor Belts	10
HeatKing® Belts	14
Proper Belt Selection	16
Conveyor Belt Data Form	17
Metric Conversions	18
Notes	19
Chute Lining and Skirtboard	20
Belt Roll Diameters.....	21
Conveyor System Components	21

Conveyor Belt Components

Conveyor belts have two basic components: the carcass, or strength member, and the rubber which protects the carcass.

Most belt carcasses are produced from fabrics that use polyester or nylon fibers, or a combination of the two. These fabrics are completely resistant to the deteriorating effects of moisture, and are resistant to most chemicals. The inherent strength of the fabrics give exceptional resistance to cutting and snagging by abrasive or gritty materials, and retain their strength indefinitely.

The rubber used in conveyor belting whether natural or synthetic is compounded to protect the carcass from the material being conveyed, and from any external conditions which could shorten the belt's useful life. The conveyor belt design seeks to ensure comparable service life for both the cover and the carcass, so that they wear out at the same rate, regardless of conditions.

GRT Rubber Technologies conveyor belt cover compounds are outlined on pages 2 and 3.

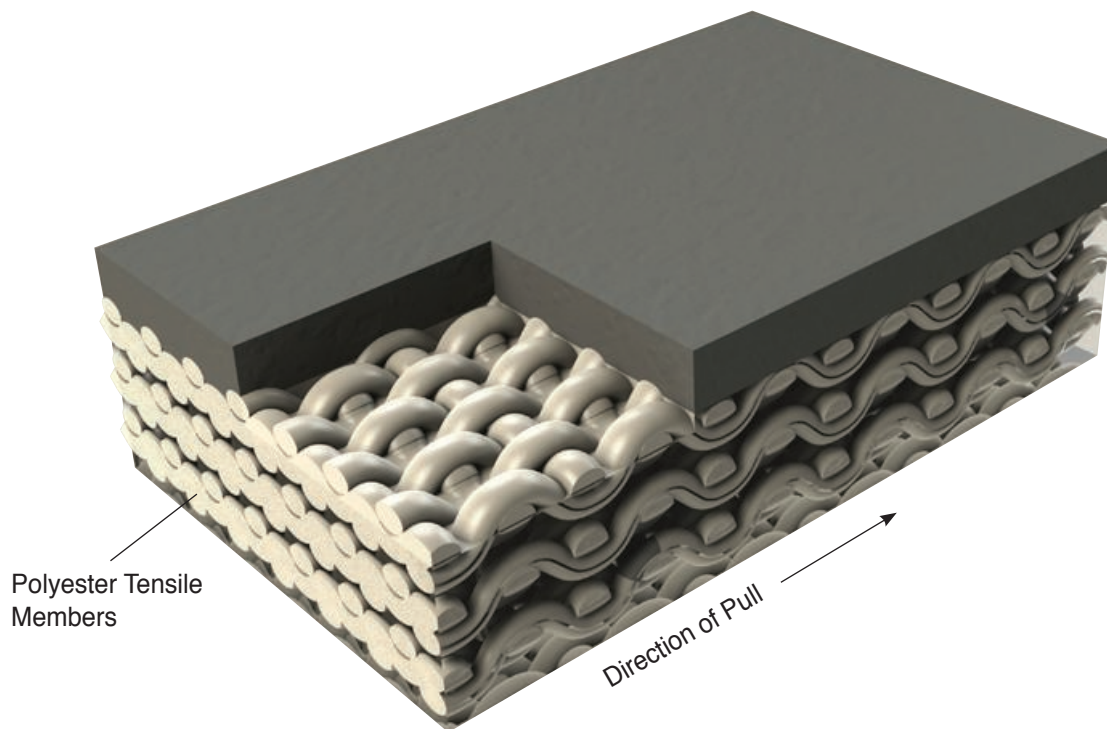

GRT Fabrics

Dependable and Durable

GRT Rubber Technologies belts are constructed of polyester or nylon fabrics. Tough polyester filament yarns give GRT belts high tensile strength. The longitudinal warp yarns carry the tension, and the transverse fill yarns hold the wrap in place and retain the mechanical fasteners. The crimp in the fabric acts as a shock absorber, permitting the fabric to deflect and adjust itself during impact shock.

Benefits

- Controlled stretch provided for by Polyester's low stretch and shrink properties reduce take-up and time needed for drive adjustments
- Resistance to mildew and rot means that wet applications will not affect the belt
- Low moisture absorption ensures better dimensional stability in wet or dry applications
- Excellent resistance to chemicals and acids allows a wide range of uses in a variety of environments
- High adhesion between plies and outstanding flexibility allow the use of smaller pulleys, yielding longer service life
- Excellent resistance to stretch and breakdown due to heat means consistent service in high temperature applications
- Superior fastener holding ability

General Purpose

DULON® CG RMA Grade 1

- Super cut and gouge resistant
- Good abrasion resistance
- Recommended for the most severe cut and gouge applications, including glass, scrap metal, ballast and hard ores.

DULON® SAR RMA Grade 1

- Specially compounded for the most abrasive applications
- Recommended for conveying smaller material not requiring the cut and gouge resistance of Dulon CG or Dulon 600 but where more abrasion resistance is needed.

WARNING

Properties/applications shown throughout this brochure are typical. Your specific application should not be undertaken without independent study and evaluation for suitability. Performance data published in this brochure has been developed from filed testing, customer filed reports and/or in house testing. While the utmost care has been used in compiling this brochure, we assume no responsibility for errors. Specifications subject to change without notice. This edition cancels all previous issues.

Cover Compounds

DULON® 600 Grade I

- RMA Grade I rubber compound
- Superior resistance to cutting, gouging and tearing from the impact of large materials
- High abrasion resistance and excellent low temperature flexibility
- Recommended for service with all kinds of hard sharp ores, quartz, trap rock, riprap, granite, glass cullet, scrap metal, ballast, etc.

DULON® Grade II

- RMA Grade II rubber compound
- Durable and long-lasting in abrasive environments
- Resistant to cut and gouges, flexible at lower temperatures
- Recommended in rugged applications not requiring the superior resistance of DULON® 600
- Ideal for conveying sand and gravel, limestone, crushed rock, slag, coke, coal, cement rock, phosphate rock and most material weighing between 50 and 120 lbs. per cubic foot

Cold Weather

ARCTIC® 600

- Specially compounded to retain flexibility in extremely low temperatures — down to -60°F (-51°C)
- Excellent cut and gouge resistance, superior abrasion resistance

Fire Resistant

FLAMEOUT® SBR

- Static conductive*†
- Designated safe in mining applications**

* According to Rubber Manufacturers Association Test 808.1

** Mine Safety and Health Administration designation 28-9

† Meets OSHA Requirements

Cover Compounds

Fire and Oil Resistant

FAVOR®

- Flame-out, oil-resistant and abrasion-resistant
- Static conductive*†
- Oil resistance ideal for milo, corn, whole soybeans, linseed, cottonseed and peanuts. Also ideal in conveying coal where some oil resistance is required.
- Designated safe in mining applications**

FAVOR® O.R.2

- Flame-out and oil-resistant
- Static conductive*†
- Formulated for conveying grain products where dust suppression systems are utilized
- Designated safe in mining applications**

FLAMEOUT® O.R.2

- Increased resistance to the deteriorating effect of materials such as coal treated lightly with oil
- Static conductive*†
- Designated safe in mining applications**

FLAMEOUT® Neoprene

- Neoprene compounds for cover and carcass
- Oil-resistant, abrasion resistant, flame-out and static conductive*†
- Designated safe in mining applications**

* According to Rubber Manufacturers Association Test 808.1

** Mine Safety and Health Administration designation 28-9

† Meets OSHA Requirements

Oil Resistant

VOR®

- Economical, static conductive and moderately oil and abrasion resistant
- Recommended for handling grain, wood chips and other lightweight materials

ROR®

- Excellent oil resistance, withstands deterioration
- Ideal for applications involving wood pitch and high terpene southern pine chips, oily grains such as flaxseed, soybeans, rice, milo, corn, cottonseed, or oil-treated materials

NITRILE

- Oil resistance prevents sponginess and swelling caused by oily materials such as petroleum based oils, sludge, sewage, and waste materials

Heat Resistant

HeatKing® RA

- Economical and long lasting
- For service handling rough abrasive materials up to 300°F (150°C): fertilizer, salt, cement, coke, slag, and steel processing

Super HeatKing® BT

- Top quality, heat-resistant compound for temperatures up to 450°F (232°C)
- Ideal to withstand the baking and cracking action of hot fine materials such as salt, ash, carbon black, foundry sand, coke, cinders, castings and slag

EPDM Hot Service

- Designed for maximum resistance to the effects of hot abrasive loads
- Recommended for hot fines to 400°F (204°C) or loads of course material to 450°F (232°C) such as clinker, calcined lime, carbon black, and foundry sand

HeatKing® OR

- A premium cover with heat and oil resistance
- Good abrasion resistance to 350°F (177°C)
- Recommended for hot asphalt paving mix, carbon pitch mixes, and hot service conditions involving petroleum-based products

Product Overview

FLEXKING®

Premium Conveyor Belts

- High quality conveyor belt for a wide variety of service applications
- Designed for use in hard rock mining, log handling, aggregate, minerals, and other critical applications
- Manufactured in widths to 72" (1800 mm)
- Tension ratings from 160 PIW* to 1250 PIW*
- Available as a made-to-order product using the cover compounds listed on page 2 and 3

DURAKING®

Rugged Dependable Conveyor Belts

- General purpose, high performance conveyor belt
- Available in two-, three-, and four-ply construction with covers of RMA Grade II rubber
- Designed primarily to convey light aggregate, coal, wood chips, and other materials that do not require high impact resistance
- Available with cover compounds Grade 2 or MOR

TECHFLEX®

Problem Solver Conveyor Belts

- Straight warp single or dual unit construction provides flexibility and superior rip and impact resistance
- Tension ratings are 220, 330 and 440 PIW* single unit, and 600, 800, and 1,000 PIW dual unit
- Ideal for applications such as log handling, riprap, ballast, hard rock, heavy ores and other difficult conditions
- Available as a made-to-order product using the cover compounds listed on page 2 and 3

HEATKING®

Hot Service Belts

- All synthetic fabrics specially woven from polyester fibers for maximum strength and minimum stretch
- Ideal for applications with constant material temperatures over 150°F (66°C)
- Widths available to 60" (1500 mm)
- Various FlexKing carcass types available; see Table I on page 5

* PIW = per inch of width



FLEXKING® Belts

GRT Rubber Technologies FLEXKING® premium conveyor belting is durable and long-lasting. The all-polyester or polyester/nylon carcass with superior adhesion skim compounds can

be vulcanized with any GRT cover compound for extra resistance in demanding applications.

Table 1 FlexKing® Belt Data

Fabrics	FlexKing Carcass	No. of Plies	Tension Ratings (lbs per inch)		Carcass Weight per linear ft. (lb. per 1 in. width)		Approx. Carcass Gauge (inches)	Belt Modulus	Recomm. Fastener FLEXCO or Equal†	
			Mech.	Vulc.	Style A*	Style B**			Plate	Hinge
80 PIW/PLY	CE1602	2	160	160	0.0475	0.0528	3/32 9/64	10,000 15,000	140	R5
	CE2403	3	240	240	0.0632	0.0699			190	R5
110 PIW/PLY	CE2202	2	220	220	0.0550	0.0603	1/8	18,000	140	R5
	CE3303	3	330	330	0.0845	0.0928	3/16	27,000	190	R5
	CE4404	4	440	440	0.1216	0.1340	17/64	36,000	190	R6
	CE5505	5	550	550	0.1587	0.1752	11/32	45,000	2	R6
125 PIW/PLY	CE6606	6	660	660	0.1957	0.2164	27/64	54,000	BR10	R6
	CE2502	2	250	250	0.0580	0.0630	9/64	19,000	190	R5
	CE3753	3	375	375	0.0889	0.0966	13/64	27,000	BR10	R5
150 PIW/PLY	CE5004	4	500	500	0.1280	0.1391	9/32	37,000	BR10	R6
	CE3002	2	300	300	0.0798	0.0728	11/64	30,000	190	R5
	CE4503	3	450	450	0.1044	0.0960	15/64	45,000	1-1/2	R6
200 PIW/PLY	CE6004	4	600	600	0.1489	0.1363	21/64	60,000	BR10	R6
	CE7505	5	750	750	0.1934	0.1766	13/32	70,000	BR10	R6
	CE4002	2	400	400	0.0897	0.0980	3/16	28,000	190	R5
250 PIW/PLY	CE6003	3	600	600	0.1060	0.1139	1/4	42,000	BR10	R6
	CE8004	4	800	800	0.1498	0.1618	3/8	55,000	BR14	R6
	CE10005	5	1000	1000	0.1937	0.2096	15/32	70,000	BR14S	R AR 8 S
	CE12006	6	1200	1200	0.2376	0.2575	1/2	84,000	NR	R AR 8 S
250 PIW/PLY	CE7503	3	750	750	0.1126	0.1210	17/64	38,000	BR14	R6
	CE10004	4	1000	1000	0.1622	0.1752	13/32	50,500	NA	R AR 8 S
	CE12505	5	1250	1250	0.2195	0.2375	17/32	62,000	NA	R AR 8 S

* Style A
DULON®
DULON® 600
HEATKING® RA
HEATKING® BT
HEATKING® EPDM
HEATKING® OR
ROR®
VOR®
NITRILE
SAR
CG

** Style B
FAVOR®
FAVOR® O.R.2
FLAMEOUT® SBR
FLAMEOUT® O.R.2
FLAMEOUT®
NEOPRENE

• New Offerings

† Fastener size recommendations may vary due to cover gauges. Consult GRT Rubber Technologies or fastener manufacturer for additional information.

* PIW = per inch of width

Table 2 FlexKing® Troughability and Load Support

Operating Conditions	Loaded or Empty		Condition A Material Weighs Less than 44 PCF††			Condition B Material Weighs 50-45-74 PCF			Condition C Material Weighs 75-99 PCF			Condition D Material Weighs 100-150 PCF		
	FlexKing Carcass	Minimum Width Troughability (inches)	Maximum Width Load Support (inches)			Maximum Width Load Support (inches)			Maximum Width Load Support (inches)			Maximum Width Load Support (inches)		
Idlers	20-35°	45°	20°	35°	45°	20°	35°	45°	20°	35°	45°	20°	35°	45°
1602	14	18	42	48	36	36	36	30	36	30	24	30	24	18
2403	20	30	60	60	48	60	48	42	42	42	36	42	36	30
2202	18	24	54	48	42	42	42	36	42	36	30	36	30	24
3303	24	30	72	72	54	60	54	48	54	48	42	48	42	36
4404	30	36	72	72	66	72	66	60	72	60	54	60	54	48
5505	30	36	72	72	66	72	66	60	72	60	54	60	54	48
6606	36	42	72	72	66	72	66	60	72	60	54	66	54	48
2502	18	30	54	48	48	48	42	36	42	36	30	36	30	24
3753	24	36	72	60	54	60	54	48	54	48	42	48	42	36
5004	30	42	72	72	72	72	72	60	72	60	54	60	54	48
3002	18	24	72	60	60	60	54	48	54	48	42	48	42	36
4503	24	30	72	66	60	66	60	54	60	54	48	54	48	42
6004	30	36	72	72	66	72	66	54	66	60	54	60	54	48
7505	36	42	72	72	72	72	72	66	72	72	66	72	60	48
4002	24	30	66	66	60	66	60	54	54	54	48	48	48	42
6003	30	36	72	72	66	72	66	60	72	60	54	60	54	48
8004	36	42	72	72	72	72	72	66	72	72	66	72	66	60
10005	42	48	72	72	72	72	72	72	72	72	72	72	72	66
12006	48	54	72	72	72	72	72	72	72	72	72	72	72	72
7503	30	36	72	72	72	72	72	60	72	60	54	60	54	48
10004	36	42	72	72	72	72	72	72	72	72	60	72	60	54

Cover Weights

Approximate weight in lbs. per 1/32" cover gauge in PIW:

DULON®, DULON® 600, VOR®, HKRA®, HKB®, EPDM, ARCTIC® 600 = 0.0167

FAVOR®, FAVOR® O.R.2, FLAMEOUT® SBR, FLAMEOUT® O.R.2, FLAMEOUT® NEOPRENE = 0.0197

HKOR®, ROR®, Nitrile = 0.0180

• New Offerings

FLEXKING® Belts

FlexKing® Impact Resistance

Conditions at the point of loading have the greatest effect on belt life and performance. The variables which determine the amount of impact on a belt include:

- Material density
- Free fall
- Lump size
- Contact speed

The impact conditions plus the speed of the belt determine the:

- Abrasion
- Cutting
- Wear forces

Table 3 FlexKing® Maximum Recommended Impact

(Free fall in inches without impact idlers or breakers)

Lump Size Carcass	4 Inch Condition*			6 Inch Condition*			8 Inch Condition*			10 Inch Condition*			12 Inch Condition*			14 Inch Condition*			16 Inch Condition*			
	Style	B	C	D	B	C	D	B	C	D	B	C	D	B	C	D	B	C	D	B	C	D
1602 2403	144 144	87 137	58 91	68	41	27	29	17	27													
2202 3303 4404 5505 6606	144	125 144 144	83 116 133 144	62 86 98 123 144	37 52 59 74 88	25 35 39 49 59	36 42 52 62	22 25 31 38	35 39 49 59	21	13	9	12	7	5							
2502 3753 5004	144	125 144 144	83 125 140	70 95 106	45 60 65	33 43 45	44 50	30 33	17 20	15 25	4 15	10	13	8	6							
3002 4503 6004 7505	144	142 144	110 140 144	81 105 142 144	48 63 85 105	33 42 57 70	34 45 60 75	20 27 36 45	33 42 57 70	31	23	14	9	13	8	5						
4002 6003 8004 10005 12006		144	127 144	94 142 144 144	57 85 113 142 144	38 57 76 94 113	40 60 80 100 120	24 36 48 60 72	38 57 76 94 113	20 31 41 51 61	12 18 25 31 37	8	18	11	7	11	7	5				
7503 10004 12505				144	118 144	88 104 144	92 124 136	72 88 124	88 104 144	56 75 88	34 60 76	20 35 40	24 36 48	20 18 26	12 14 17	18 20 30	12 14 24	8 12 16	12 18 24	8 10 12	6 8 10	

With impact idlers and/or breakers, increase the maximum recommended impact (free fall in inches) by this amount:

Add 5" Rubber Impact Idlers	499	299	199	148	89	59	62	37	25	32	19	13	19	11	7	12	7	5	8	5	3
Add for Nylon Breaker	69	42	28	21	12	8	9	5	3.5	4	2.5	2	3	1.5	1	1.5	1	0.5	1	0.5	0.5

Table 4 Equivalent Chute Free fall (inches)

Chute Angle	Belt Speed (ft./min.)						
	100	200	300	400	500	600	800
30°	0.26	1	2.3	4	6.5	9.3	16.5
45°	0.50	2	4	8	13	18.6	33
Over 45°	Total vertical height of chute in inches						

Impact and abrasion are equal to free fall in inches:

Impact = drop in inches from the end of the chute to the belt plus the equivalent free fall inside the chute

If the chute angle is either 30° or 45° from the horizontal, an equivalent chute free fall calculation can be assigned for different belt speeds. (See Table 4, below.)

The length of low-angle chutes is not a factor, since friction restricts the speed of the material to a fairly constant level, regardless of length.

However, if a chute angle with the horizontal is over 45°, the impact (free fall in inches) equals the vertical distance from the top of the chute to the surface of the belt.

(See page 13 for more information on impact resistance)

FLEXKING® Belts

FlexKing® Specifications

Table 5 FlexKing® Minimum Recommended Pulley Diameter (inches)

FlexKing Carcass	Tension Rating (lb./inch)	Tandem or Dual Drive	Head or Single Drive				Tail and Snubs
			Over 80% of Rating	60-80% of Rating	40-60% of Rating	Under 40% of Rating	
1602	160	18	16	14	12	10	10
2403	240	20	18	16	14	12	12
2202	220	18	16	14	12	10	10
3303	330	20	18	16	14	12	12
4404	440	30	24	20	18	16	16
5505	550	36	30	24	20	18	18
6606	660	42	36	30	24	20	20
2502	250	18	16	14	12	10	10
3753	375	20	18	16	14	12	12
5004	500	30	24	20	18	16	16
3002	300	24	18	16	14	12	12
4503	450	30	24	20	18	16	16
6004	600	36	30	24	20	18	18
7505	750	42	36	30	24	20	20
4002	400	24	20	18	16	14	14
6003	600	30	24	20	18	16	16
8004	800	36	30	24	20	18	18
10005	1000	42	36	30	24	20	20
12006	1200	48	42	36	30	24	24
7503	750	36	30	24	20	18	18
10004	1000	42	36	30	24	20	20
12505	1250	48	42	36	30	24	24

Table 6 Recommended thickness of FlexKing® Belt Top Cover (inches)

Belt Cycle 2L+S	Moderately Abrasive Materials				Abrasive Materials				Heavy Abrasive Materials			
	Sand, loam, grains, soft coal, crushed coke cinders, gravel, wood chips				Hard coal, limestone, crushed ores, slag, sinter, coarse gravel				Rock, heavy ores, slate, trap rock			
	Lump Size (inches)				Lump Size (inches)				Lump Size (inches)			
	To 1/2"	1/2" - 2"	2" - 6"	Over 6"	To 1/2"	1/2" - 2"	2" - 6"	Over 6"	To 1/2"	1/2" - 2"	2" - 6"	Over 6"
4.0	1/8	3/16	3/16	1/4	3/16	3/16	1/4	5/16	3/16	3/16	1/4	5/16
2.0	1/8	3/16	3/16	1/4	3/16	3/16	1/4	5/16	3/16	3/16	1/4	3/8
1.0	1/8	3/16	1/4	1/4	3/16	3/16	5/16	3/8	3/16	1/4	3/8	3/8
0.5	1/8	3/16	1/4	5/16	3/16	1/4	5/16	3/8	5/16	3/8	3/8	3/8
0.2	3/16	1/4	5/16	5/16	3/16	5/16	3/8	3/8	5/16	3/8	3/8	3/8

* L = Center to center of conveyor terminals in feet

S = Belt speed in feet per minute

FlexKing® Belt Bottom and Pulley Covers

Bottom cover for all belts will be 1/16" unless otherwise specified. 1/16" bottom covers are preferable for belts with top covers 1/8" thick and over.

Where special heavy cover impact belts are required or where

sharp or abrasive materials, 3/32" or 1/8" pulley covers may be specified. If further protection is desired, a nylon leno breaker may be included in either or both covers 3/32" or thicker.

FLEXKING® Belts for Elevator Service

Benefits

- Superior service life and hazard resistance
- Excellent bucket holding capability, flexing strength, and small pulley flexing capability
- Wide range of configurations — can be custom-designed and special ordered

Table 7 Carcass Selection — Maximum Elevator Bucket Projection (inches)

Carcass	1602	2403	2202	3303	4404	5505	6606	3002	4503	6004	7505	4002	6003	8004	10005	12006	7503	10004	12505	
Elevator Tension Rating PIW*	140	210	160	240	320	400	480	220	330	440	560	300	465	620	775	930	650	910	1130	
Grain Service	5"	8"	6"	9"	10"	10"	10"	7"	10"	10"	11"	8"	10"	12"	16"	20"	12"	14"	16"	
Industrial: 100 PCF** or less Lump Size 1" and under	Spaced	5"	7"	6"	8"	10"	10"	12"	7"	9"	10"	11"	8"	10"	11"	12"	14"	12"	14"	16"
Industrial: 100 PCF** or less Lump Size 2" and under	Continuous	NR	7"	5"	8"	10"	10"	11"	7"	9"	12"	13"	8"	10"	14"	16"	20"	12"	14"	16"
Industrial: 100 PCF** or less Lump Size 2" and under	Spaced	NR	6"	5"	7"	9"	9"	9"	6"	9"	9"	9"	7"	9"	10"	11"	12"	10"	12"	12"
Industrial: 100 PCF** or less Lump Size 2" and under	Continuous	NR	5"	NR	7"	9"	9"	9"	6"	9"	9"	10"	7"	9"	11"	14"	16"	12"	14"	16"
Industrial: 100 PCF** or less Lump Size 2" and under	Spaced	NR	5"	NR	6"	8"	8"	8"	6"	8"	9"	8"	6"	8"	9"	10"	11"	9"	11"	11"
Industrial: 100 PCF** or less Lump Size 2" and under	Continuous	NR	NR	NR	7"	8"	8"	8"	6"	8"	8"	9"	6"	8"	10"	12"	14"	10"	12"	14"
Industrial: 100 PCF** or less Lump Size 2" and under	Spaced	NR	NR	NR	NR	8"	8"	8"	NR	8"	8"	8"	NR	8"	8"	9"	10"	10"	12"	14"
Industrial: 100 PCF** or less Lump Size 2" and under	Continuous	NR	NR	NR	NR	8"	8"	8"	NR	8"	8"	8"	NR	8"	9"	10"	12"	9"	11"	11"
Approximate Carcass Gauge	3/32	9/64	1/8	3/16	17/64	11/32	27/64	11/64	15/64	21/64	13/32	3/16	1/4	3/8	15/32	1/2	17/64	13/32	17/32	
Flexco Fastener	Plate †	140	190	140	190	190	2	BR10	190	1-1/2	BR10	BR10	190	BR10	BR14	NR	NR	BR14	NA	NA
Recommended	Hinged †	R5	R5	R5	R5	R6	R6	R6	R5	R6	R6	R6	R5	R6	R6	NR	NR	R6	RAR8S	RAR8S
Min. Head Pulley at 100% Tension		16	18	16	18	24	30	36	18	24	30	36	20	30	36	42	48	30	36	48
Min. Head Pulley at 80% Tension		14	16	14	16	20	24	30	16	20	24	30	18	24	30	36	42	24	30	42
Min. Head Pulley at 60% Tension		12	14	12	14	18	20	24	14	18	20	24	16	20	24	30	36	20	24	36

* PIW = per inch of width

** PCF = Pounds per cubic foot

† Fastener size recommendation may vary due to cover gauges. Consult GRT or the fastener manufacturer for additional information.

Note: The selection of appropriate cover compound and gauge of elevator belts is the same as for conventional belts.

The minimum ply-construction of FlexKing elevator belts is thinner than that of conventional belts which FlexKing may be replacing; therefore careful selection of bucket bolts is critical. The "A" dimension (see drawing) should be at least 1/16" (1.6 mm) shorter than the total gauge of FlexKing belt. The "B" dimension (see drawing) should be at least 1/16" (1.6mm) shorter than the total dimension of the belt, bucket wall and washers.

You should tighten the nuts to ensure good set and proper compression; then retighten after elevator operations begin — at least once in the first 24 hours.

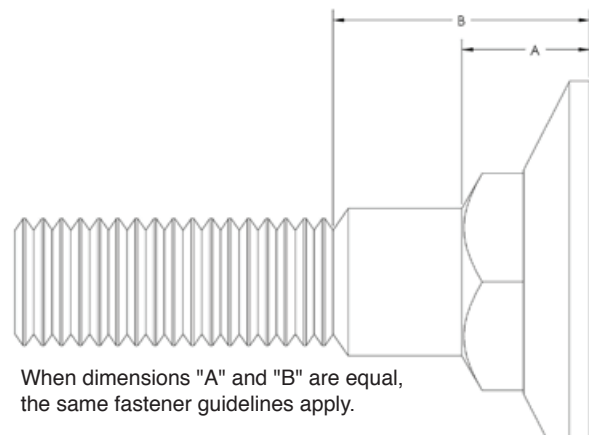

When dimensions "A" and "B" are equal, the same fastener guidelines apply.

DURAKING® Belts

Construction

Specifications	Style 220	Style 330	Style 440	
Number of plies	2	3	4	
Vulcanized Rating (PIW)	220	330	440	
Mechanical Rating (PIW)	220	330	440	
Approx. carcass gauge (inch)	7/64	5/32	7/32	
Approx. carcass weight (lbs./sq.ft)	0.56	0.89	1.25	
Cover weight (lbs./sq.ft, 1/32" thick)	0.20	0.20	0.20	
Recommended Fasteners	Plate	140R	190E	2E
	Hinge	R5	R5	R5 1/2

Load Support (Maximum Belt Width)

Material Weight	Idlers	Style 220	Style 330	Style 440
1 to 60 PCF**	20°	42"	60"	66"
	35°	42"	54"	60"
	45°	36"	48"	54"
61 to 120 PCF	20°	42"	54"	54"
	35°	36"	48"	48"
	45°	30"	42"	42"

**PCF = the weight of the material the belt will carry, stated in pounds per cubic foot

Minimum Recommended Pulley Diameters

Tension Rating	Style 220	Style 330	Style 440
Over 80%	16"	18"	24"
60-80%	14"	16"	20"
40-60%	12"	14"	18"
Below 40%, tails, snubs	10"	12"	16"

Technical Data

Cover: Grade II rubber (standard)
 Carcass: All polyester
 Service
 Standard: Aggregates, clay, coal, ore, phosphates, sand, salt
 Available with MOR compound for: oil resistance, wood chips, wood bark, sawdust, whole grains

Troughability

Idlers	Style 220	Style 330	Style 440
20"	15"	24"	24"
35"	18"	24"	24"
45"	24"	30"	30"

WARNING

Properties/applications shown throughout this brochure are typical. Your specific application should not be undertaken without independent study and evaluation for suitability. Performance data published in this brochure has been developed from field testing, customer field reports and/or in-house testing. While the utmost care has been used in compiling this brochure, we assume no responsibility for errors. Specifications subject to change without notice. This edition cancels all previous issues.

TECHFLEX® Belts

High Strength Carcass Construction

Benefits

- Straight warp yarns in parallel planes with special binder provide extra strength
- Strong mechanical and chemical bonding between compound and textile increases strength
- Reinforcing eliminates need for multiple plies, resulting in a thinner and more flexible belt

Extra Flexibility

- Allows belt to operate over smaller pulleys
- Resists flex fatigue, lasts longer
- Easier to install in hard to access areas

Excellent rip and impact resistance

- Special weave design with fill yarns above and below warp yarns increases rip resistance
- Planes of straight fibers offer additional resistance of lump impact

Low Stretch

- Straight warp weave stretches less than crimped weaves fabric
- Longer belt life

Superior troughing and load support

- Flexibility in carcass design ensures excellent empty belt troughing
- Parallel planes of straight crosswise members give strength and stability to bridge the idler roll gaps under full load

WARNING

Properties/applications shown throughout this brochure are typical. Your specific application should not be undertaken without independent study and evaluation for suitability. Performance data published in this brochure has been developed from field testing, customer field reports and/or in-house testing. While the utmost care has been used in compiling this brochure, we assume no responsibility for errors. Specifications subject to change without notice. This edition cancels all previous issues.

TECHFLEX® I

Technical Data

Construction: Straight warp single unit
Material: All polyester
Tension Ratings: 220-440 PIW*
Applications: Log handling, riprap, ballast, hard rock, heavy ores, etc.

TECHFLEX® II

Technical Data

Construction: Straight warp double unit
Material: Polyester and Nylon
Tension Ratings: 600-1500 PIW*
Applications: Log handling, riprap, ballast, hard rock, heavy ores, etc.

*PIW = per inch

TECHFLEX® II Dual Unit Straight Warp Carcass

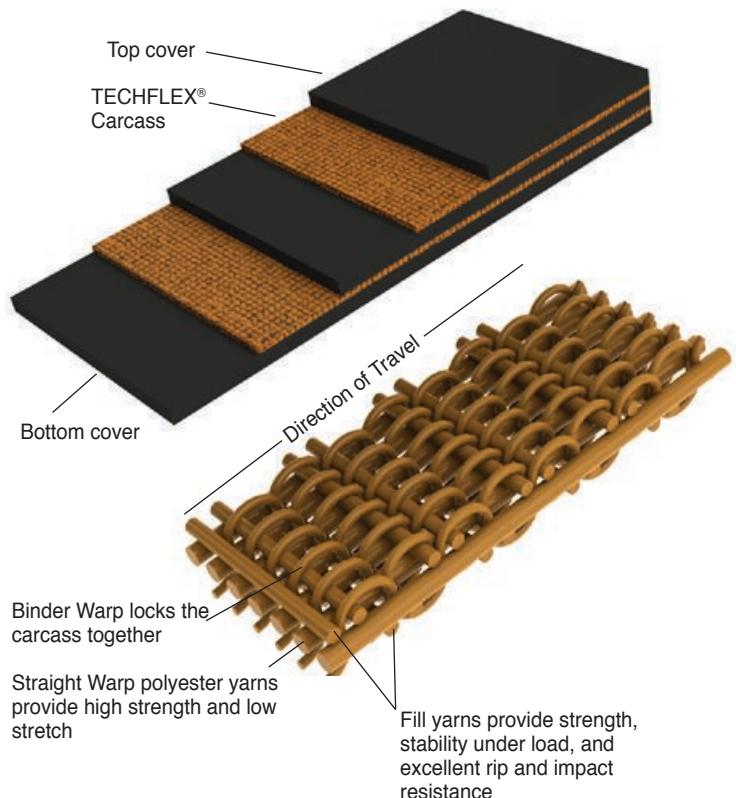

TECHFLEX® Specifications

Rated Operating Tension (PIW - Pounds per inch of width)

Belt Type	GRT TechFlex® I			GRT TechFlex® II		
	220	330	440	600	800	1000
Mechanical Fastener	220	330	440	600	800	900
Vulcanized Splice	220	330	440	600	800	1000

CAUTION: The failure to select the proper fasteners and to install them correctly could result in a splice failure, causing belt and material to roll back or fall, with the potential to damage equipment and cause serious injury or death.

Mechanical splice - recommended fasteners

Fastener choice is dependent on belt tension, belt thickness, pulley diameters and operating conditions. Consult the fastener manufacturer's catalog for fastener recommendations and installation procedures.

Cover Gauges

1/16" = 0.062" 1/4" = 0.250"
 3/32" = 0.094" 5/16" = 0.312"
 1/8" = 0.125" 3/8" = 0.375"
 5/32" = 0.156" 7/16" = 0.438"
 3/16" = 0.188" 1/2" = 0.500"

TechFlex® Belt Thickness (inches)

Belt Type	GRT TechFlex® I			GRT TechFlex® II		
	220	330	440	600	800	1000
Carcass Gauge	0.110	0.131	0.140	0.250	0.290	0.310

Recommended Thickness of TechFlex® Belt Top Cover (inches)

Belt Type	Moderately Abrasive Materials				Abrasive Materials				Heavy Abrasive Materials			
	Sand, loam, grains, soft coal, crushed coke cinders, gravel, wood chips				Hard coal, limestone, crushed ores, slag, sinter, coarse gravel				Rock, heavy ores, slate, trap rock			
	Lump Size (inches)				Lump Size (inches)				Lump Size (inches)			
	To 1/2"	1/2" - 2"	2" - 6" ^{***}	Over 6"	To 1/2"	1/2" - 2"	2" - 6" ^{***}	Over 6"	To 1/2"	1/2" - 2"	2" - 6" ^{***}	Over 6" [†]
TechFlex® I*												
Top cover (min.)	1/8	3/16	1/4	1/4	3/16	3/16	5/16	5/16	3/16	1/4	5/16	3/8
Bottom cover (min.)	1/16	3/32	1/8	1/8	3/32	3/32	5/32	3/16	3/32	1/8	5/32	3/16
TechFlex® II**												
Top cover (min.)	1/8	3/16	1/4	1/4	3/16	3/16	5/16	3/8	3/16	1/4	5/16	3/8
Bottom cover (min.)	1/16	1/16	3/32	3/32	1/16	1/16	3/32	1/8	1/16	3/32	3/32	1/8

* Manufactured with a minimum top to bottom cover thickness ratio of 2:1.

** Manufactured with a minimum top to bottom cover thickness ratio of 3:1.

† DULON® 600 covers are recommended.

NOTE: When special heavy cover impact belts are required, or where pulley cover wear may be a problem because of wet, sticky, sharp or abrasive materials, covers heavier than the minimum thickness above may be specified.

TechFlex® Belt Weight (PIW per linear foot)

Add carcass weight to cover weight to obtain belt weight. Multiply by belt width in inches to obtain weight per foot.

Carcass Weights (approximate)

Belt Type	GRT TechFlex® I			GRT TechFlex® II		
	220	330	440	600	800	1000
Carcass Weight	.03	.041	.052	.101	.115	.135

Cover Weights (approximate)

Cover Thickness	1/16"	3/32"	1/8"	5/32"	3/16"	1/4"	5/16"	3/8"	7/16"	1/2"
Cover Weight	0.037	0.056	0.075	0.094	0.112	0.150	0.188	0.225	0.263	0.300

TECHFLEX® Specifications

TechFlex® Troughability and Load Support

Operating Conditions	Empty Belt			Condition A Material Weighs Less than 44 PCF††			Condition B Material Weighs 45-74 PCF			Condition C Material Weighs 75-99 PCF			Condition D Material Weighs 100-150 PCF		
	Minimum Width Troughability (inches)			Maximum Width Load Support (inches)			Maximum Width Load Support (inches)			Maximum Width Load Support (inches)			Maximum Width Load Support (inches)		
GRT TechFlex® Belt	20°	35°	45°	20°	35°	45°	20°	35°	45°	20°	35°	45°	20°	35°	45°
Idlers	20°	35°	45°	20°	35°	45°	20°	35°	45°	20°	35°	45°	20°	35°	45°
220	14	20	24	66	54	48	54	42	36	48	36	30	42	36	30
330	18	24	24	72	60	48	60	54	42	54	42	36	48	42	36
440	18	24	24	72	66	54	72	60	48	66	54	42	60	48	42
600	30	36	42	72	72	72	72	72	72	72	72	72	72	72	72
800	30	36	42	72	72	72	72	72	72	72	72	72	72	72	72
1000	30	36	42	72	72	72	72	72	72	72	72	72	72	72	72

Recommended Minimum Pulley Diameters - For vulcanized splice in inches

TechFlex®	Tension Rating (lb./inch)	Head or Single Drive			
		Over 80%	60-80%	40-60%	Under 40%
220	220	16	14	12	10
330	330	20	18	16	14
440	400	24	20	18	16
600	600	30	24	20	18
800	800	36	30	24	20
1000	1000	42	36	30	24

CAUTION: The failure to select the proper fasteners and to install them correctly could result in a splice failure, causing belt and material to roll back or fall, with the potential to damage equipment and cause serious injury or death.

Belt Modulus of Elasticity (PIW)

Belt Type	Modulus
TechFlex® I 220	24,500
330	26,500
440	28,000
TechFlex® II 600	60,000
800	66,500
1000	71,500

CAUTION: FOR MECHANICAL SPLICE

The table rates are for vulcanized spliced belts only. The use of mechanical fasteners may increase the required minimum pulley diameters. Fastener choice is dependent on belt tension, belt thickness, minimum pulley diameter and operating conditions. Consult the fastener manufacturer for recommendations and installation procedures.

WARNING

Properties/applications shown throughout this brochure are typical. Your specific application should not be undertaken without independent study and evaluation for suitability. Performance data published in this brochure has been developed from field testing, customer field reports and/or in-house testing. While the utmost care has been used in compiling this brochure, we assume no responsibility for errors. Specifications subject to change without notice. This edition cancels all previous issues.

TECHFLEX® Impact Resistance

Maximum Recommended Impact (Free fall in inches)

Max. Lump Size TechFlex® I Style	10 Inch Condition*			12 Inch Condition*			14 Inch Condition*			16 Inch Condition*			18 Inch Condition*		
	B	C	D	B	C	D	B	C	D	B	C	D	B	C	D
220	83	62	42	48	36	24	34	25	17	23	17	11	16	12	8
330	•	113	76	87	66	44	62	46	31	41	31	21	29	22	15
440	•	124	83	95	72	48	67	50	34	45	34	23	32	24	16
Max. Lump Size TechFlex® II Style	10 Inch Condition*			12 Inch Condition*			14 Inch Condition*			16 Inch Condition*			18 Inch Condition*		
	B	C	D	B	C	D	B	C	D	B	C	D	B	C	D
600	•	•	125	144	108	72	101	76	51	68	51	34	48	36	24
800	•	•	143	•	123	82	116	87	58	78	58	39	55	41	37
1000	•	•	•	•	•	101	142	106	71	95	71	48	67	50	43

- * Condition B: Material weighs up to 74 pounds per cubic foot (PCF)
- Condition C: Material weighs 75-99 pounds per cubic foot (PCF)
- Condition D: Material weighs 100-150 pounds per cubic foot (PCF)
- Greater than 144" free fall

CAUTION: The failure to follow industry-accepted design practices[†] to lessen the impact of falling materials, or the failure to use impact reduction equipment such as impact idlers may result in:

1. Premature belt failure resulting from impact damage and/or fastener pullout
2. Damage to idlers and other conveyor components

[†] Source: National Industrial Belting Association (NIBA), NIBA Tech-Notes #10, Impact Resistance of Belting.

Impact Guidelines

The impact resistance based on inches of free fall is calculated assuming the use of impact reduction equipment such as impact idlers. If impact reduction equipment is not used, free fall inches must be reduced by one-half. Ratings are based on 10% lumps and 90% fines which includes material sizes up to 4 inches.

Optimum loading and material transfer design can lessen the force of impacting lumps on the belt and extend belt life.

Follow these industry accepted design practices where applicable:

1. Reduce the size or weight of the material
2. Break the fall of lumps with bars, chains or chutes to reduce impact
3. Design loading system to insure the material is loaded in the same direction as the belt travel
4. Load lumps on a bed of fines to reduce impact
5. Do not load in transition areas
6. Use impact idlers and if possible design the loading area to strike the belt between idlers in an open unsupported span
7. Increase the belt cover thickness and use breakers in the cover or an extra ply for increased impact resistance

HEATKING® Belts

Benefits

Ideal for applications with constant material temperatures over 150°F (66°C)

All synthetic fabrics specially woven from polyester fibers for excellent dimensional stability - minimal strength loss or stretch in high temperatures

Highly resistant to chemicals and acids, even in hot environments

Low moisture absorption ensures reliable service in wet applications

Widths available to 60" (1500 mm)

A wide range of FlexKing® carcass types are available



HEATKING® RA (HKRA)

SBR compound designed specifically for abrasion resistance and heat resistance up to 300°F (149°C)

Proven economical and long lasting

Ideal for conveying coke, steel, slag, cement, salt and fertilizer

HEATKING® OR (HKOR)

High quality nitrile elastomer compound is heat and oil resistant to temperatures up to 350°F (177°C)

Excellent service handling hot asphalt paving mix, carbon pitch mixes, and other hot petroleum-based products

Super HEATKING® BT (HKBT)

Top quality heat resistant chlorobutyl compound

Resists the baking and cracking action of hot materials up to 450°F (232°C)

Suited for applications such as salt, ash, carbon black, foundry sand, cement clinker, and calcined lime

*Production widths available in rolls to 60" wide. Cover compounds may be used on standard 110 PIW/PLY fabric belts and other GRT carcasses on request as made to order. Call Customer Service at: 800.643.0134.

WARNING

Properties/applications shown throughout this brochure are typical. Your specific application should not be undertaken without independent study and evaluation for suitability. Performance data published in this brochure has been developed from field testing, customer field reports and/or in-house testing. While the utmost care has been used in compiling this brochure, we assume no responsibility for errors. Specifications subject to change without notice. This edition cancels all previous issues.

HEATKING® EPDM

- Provides maximum resistance to hot, abrasive loads
- Recommended for hot fines to 400°F (204°C) or loads of course materials to 450°F (232°C)
- Ideal for clinker, calcined lime, carbon black and foundry sand

HEATKING® SG

- Designed to perform reliably under the most adverse temperature conditions
- EPDM cover compounds handles temperatures up to 450°F (232°C)
- Proprietary carcass gives structural integrity and prevents burn-through or distortion in high temperatures up to 1000°F (538°C)
- Typical applications include cement, clinker, calcined lime and foundry sand

HEATKING® Belts



HEATKING® RA

HEATKING® OR

HEATKING® BT

HEATKING® EPDM

HEATKING® SG Carcass integrity to 1000°F (538°C)

Service Class I

Fully enclosed belts (all materials, high ambient temperatures)

HEATKING® RA

HEATKING® OR

HEATKING® BT

HEATKING® EPDM

HEATKING® SG Carcass integrity to 1000°F (538°C)

Service Class II

Fines or fines and course material (Normal ambient temperatures)

HEATKING® RA

HEATKING® OR

HEATKING® BT

HEATKING® EPDM

HEATKING® SG Carcass integrity to 1000°F (538°C)

Service Class III

Course material only - 2-inch and over (Normal ambient temperatures)

HEATKING® Data

Fabrics	Carcass	Ply	Tension Ratings (lbs per inch)		Belt wt. per linear ft. in lb. per 1in. width HEATKING® RA, OR, BT, EPDM	Approximate Carcass Gauge (inches)	Belt Modulus	Recommended Fastener FLEXCO or =	
			Mech.	Vulc.				Plate	Hinge
110 PIW/PLY	Polyester	2	220	220	0.1886	1/8	18,000	140	R5
	Polyester	3	330	330	0.2515	3/16	27,000	190	R5

* For SG specifications contact Customer Service at: 800.643.0134.

Recommended Minimum Pulley Diameter (inches)

Ply	Tension Rating (lb./inch)	Tandem or Dual Drive	Head or Single Drive				Tail and Snubs
			Over 80% of Rating	60-80% of Rating	40-60% of Rating	Under 40% of Rating	
2	220	18	16	14	12	10	10
3	330	20	18	16	14	12	12

* Wing pulleys not recommended

CAUTION: Heat resistance temperatures are intended as a guide and are not absolute or guaranteed. As recommended maximum temperatures are reached or exceeded, belt life will decrease on an accelerated basis unless effective measures are taken to cool the belt.

Proper Belt Selection

A Combination of Key Operating Factors

Since the belt itself is one of the most costly components of a typical conveyor system, it is obviously important to select the right GRT Rubber Technologies belt for the job.

When recommending a belt, whether on a new system or as a replacement on an existing system, an objective study of the system and all the relevant operating conditions is of utmost importance. Belt selection must take into account six key criteria: system tension, load support, troughability, impact rating, pulley diameters, and covers (compound and thickness).

Tension

The tension members in a belt carcass provide the longitudinal strength to move the load and also withstand torque from the system start up. Belt tension is normally defined as required PIW (pounds per inch of width) and can be calculated using the following quick method:

$$PIW = \frac{HP (1+K) 33,000}{S \times W}$$

PIW - Unit Tension
 HP - System Motor Horsepower
 K - Drive Factor
 S - Belt Speed (Foot per Minute)
 W - Width of Belt
 33,000 - Constant

K. Drive Factor

Drive Pulley Degree of Wrap	Screw Take up		Counterweight Take up	
	Bare Pulley f=0.20	Lagged Pulley f=0.25	Bare Pulley f=0.30	Lagged Pulley f=0.35
180°	1.00	.84	.64	.50
200°	.86	.72	.54	.42
210°	.80	.67	.50	.38
220°	.74	.64	.46	.35
240°	.66	.54	.40	.30
300°	.46	.37	.26	.19
360°	.33	.26	.18	.13
420°	.25	.19	.12	.08
480	.19	.14	.09	.06

While this method is quick, it does not represent the most accurate method for belt tension selection. A more precise and exact calculation can be made using the Conveyor Belt Data Form supplied on the next page. Completely fill in the form and send to the factory for review and recommendations of a proper GRT belt for your use.

Load Support

Proper carcass traverse rigidity must be maintained throughout the belt life to support the load capacity of the belt and bridge the idler junction gaps. Load support values for GRT belts based on the number of plies and the type of belt are provided in the preceding pages and stated as a maximum width in inches.

Troughability

In addition to having adequate load support, the belt must still be flexible enough to make proper contact with all three troughing idler rolls when the belt is empty. If not, proper belt training cannot be accomplished. Troughability values for GRT belts are provided in the preceding pages and states as a minimum width in inches.

Impact Rating

The type of fiber, or tension member, weave design, and number of plies determines the impact rating of a belt and its ability to absorb impact energy. This information in addition to knowledge of the size and type of material to be conveyed, how the material is to be loaded and the conveyor's system's impact arrangement allows us to choose the proper GRT belt. Impact rating of a belt carcass as stated in drop to belt in inches must not be exceeded.

Pulley Diameters

Proper sized pulleys allow the belt to operate at its full tension rating without additional stress and compression on the inner plies. Minimum pulley diameters for conveyor systems are stated in inches for various belt carcasses and differing tension ratings.

Covers

Covers are compounded for a wide variety of applications and are selected to be compatible with the actual materials that are to be conveyed. GRT offers a full line of cover compounds, as explained in the previous pages that will handle almost any conveying applications. Cover thickness for a specified compound is also a function of the application, the type of material to be conveyed, and the frequency of the loading cycle. A chart has been provided on page 10 for recommended thickness of a GRT belt cover.

Conveyor Belt Data Form

Sketch conveyor configuration, locating drive, take-up, curves and tripper limits.

Sheet No.: _____ Date: _____ Salesman: _____
 Customer: _____
 Distributor Engineering Company Equipment Manufacturer
 Conveyor no. or description: _____

Conveyor Belt Operating Data and Recommendations

<p style="text-align: center;">Material Data</p> <p>Material: _____ Max. lump size: _____ inches Average Size: _____ inches *Maximum capacity: _____ tons/hour Average capacity: _____ tons/hour Oil: <input type="checkbox"/> None <input type="checkbox"/> Some <input type="checkbox"/> A lot</p> <p style="text-align: center;">Drive Data</p> <p>Location: <input type="checkbox"/> Head <input type="checkbox"/> Tail <input type="checkbox"/> Between Type: <input type="checkbox"/> Single <input type="checkbox"/> Tandem <input type="checkbox"/> Dual Motor horsepower: _____ *Lagged: <input type="checkbox"/> Yes <input type="checkbox"/> No *Wrap angle: _____</p> <p style="text-align: center;">Pulley Diameters</p> <p>Drive pulley dia.: _____ inches Head pulley dia.: _____ inches Tail pulley dia.: _____ inches Take-up pulley dia.: _____ inches Snub pulley dia.: _____ inches Bend pulley dia.: _____ inches Wing tail: <input type="checkbox"/> Yes <input type="checkbox"/> No</p>	<p style="text-align: center;">Operating Data</p> <p>*Belt Width _____ inches *Belt Speed _____ feet Temperature: _____ <input type="checkbox"/> Wet <input type="checkbox"/> Dry</p> <p>Length</p> <p>*Conveyor center: _____ feet Installed belt length: _____ feet</p> <p>Elevation</p> <p>*Vertical lift: _____ feet Angle on incline: _____</p> <p style="text-align: center;">Take-up</p> <p>Type: <input type="checkbox"/> Gravity <input type="checkbox"/> Screw <input type="checkbox"/> Auto Travel: _____ feet _____ inches Location from head: _____ feet From tail: _____ feet Counterweight: _____ lbs.</p> <p style="text-align: center;">Loading Data</p> <p>Direction in line: <input type="checkbox"/> Side <input type="checkbox"/> Vertical Type Loader: _____ *Drop to belt _____ feet Chute Angle _____ Loading idlers: <input type="checkbox"/> Impact <input type="checkbox"/> Plain Space at loading: _____ inches Impact station length: _____ feet</p>
<p>Splice: <input type="checkbox"/> Mech. <input type="checkbox"/> Vulc. Idler Spacing: _____ inches Trough angle: _____ *Tripper <input type="checkbox"/> Yes <input type="checkbox"/> No Lift: _____ feet Fixed: _____ Transition distance: Head: _____ inches Tail: _____ Inches Previous or current belt specification: _____ Belt recommendation: _____</p>	

Belt Selection Data

<p style="text-align: center;">Horsepower Data</p> <p>HPX: _____ HPY: _____ HPZ: _____ Tripper Horsepower: _____ Total Horsepower: _____</p>	<p style="text-align: center;">Tension Data</p> <p>Effective belt tension: _____ lbs Slack side tension T (2): _____ lbs Maximum belt tension: _____ lbs Tension per inch of belt: _____ lbs</p>
---	--

* MUST be completed

Metric Conversion Charts

Metric Conversion Table

Millimeters x .03937 = inches	Liters + 28.316 = cubic feet
Millimeters + 25.4 = inches	Hectoliters x 3.531 = cubic feet
Centimeters x 0.3937 = inches	Hectoliters x 2.84 = bushels (2150.42 cubic inches)
Centimeters 2.54 = inches	Hectoliters x .131 =cubic yards
Meters x 39.37 = inches	Hectoliters + 26.42 = gallons (231 cubic inches)
Meters x 3.281 =feet	Grams x 15.432 = grains
Meters x 1.094 = yards	Grams + 981 = dynes
Kilometers x .621 = miles	Grams (water) + 29.57 = fluid ounces
Kilometers = 1.6093 = miles	Grams + 28.35 = ounces avoirdupois
Kilometers x 3280.8693 = feet	Grams per Cu. Cent. + 27.7 = pounds per cubic inch
Square Millimeters x .00155 = square inches	Joule x .7373 = foot pounds
Square Millimeters + 645.1 = square inches	Kilograms x 2.2046 = pounds
Square Centimeters x .155 = square inches	Kilograms x 35.3 = avoirdupois
Square Centimeters + 6.451 = square inches	Kilograms + 907.2 = tons (2,000 pounds)
Square Meters x 10.764 = square feet	Kilograms per Sq. Cent. x 14.223 = pounds per square inch
Square Kilometers x 247.1 = acres	Kilogram meters x 7.233 = foot pounds
Hectare x 2.471 = acres	Kilograms per Meter x .062 = pounds per foot
Cubic Centimeters 16.383 = cubic inches	Kilograms per Cu. Meter x .062 = pounds per cubic foot
Cubic Centimeters + 3.69 = foot drams (USP)	Tonneau x 1.1023 = tons (2,000 pounds)
Cubic Centimeters + 29.57 = fluid ounces (USP)	Kilowatts x 1.34 = horse power
Cubic Meters x 35.315 = cubic feet	Watts + 746 = horse power
Cubic Meters x 1.308 = cubic yards	Watts x.7373 = foot pounds per second
Cubic Meters x 264.2 = gallons (213 cubic inches)	Calorie x 3.968 = BTU
Liters x 61.022 = cu. in.	Cheval Vapeau +.9863 = horse power
Liters x 33.84 = fluid ounces (USP)	(Centigrade x 1.8) + 32 = degrees Fahrenheit
Liters x .2642 =gallons (231 cubic inches)	
Liters + 3.78 = gallons (231 cubic inches)	

Millimeter to Inch Conversion 1" = 25.4mm

mm	inch	mm	inch	mm	inch	mm	inch	mm	inch	mm	inch	mm	inch
1	0.039370	26	1.023622	51	2.007874	76	2.992126	101	3.976378	126	4.960630	151	5.944882
2	0.078740	27	1.062992	52	2.047244	77	3.031496	102	4.015748	127	5.000000	152	5.984252
3	0.118110	28	1.102362	53	2.086614	78	3.070866	103	4.055118	128	5.039370	153	6.023622
4	0.157480	29	1.141732	54	2.125984	79	3.110236	104	4.094488	129	5.078740	154	6.062992
5	0.196850	30	1.181102	55	2.165354	80	3.149606	105	4.133858	130	5.118110	155	6.102362
6	0.236220	31	1.220472	56	2.204724	81	3.188976	106	4.173228	131	5.157480	156	6.141732
7	0.275591	32	1.259843	57	2.244094	82	3.228346	107	4.212599	132	5.196851	157	6.181102
8	0.314961	33	1.299213	58	2.283465	83	3.267717	108	4.251969	133	5.236221	158	6.220473
9	0.354331	34	1.338583	59	2.322835	84	3.307087	109	4.231339	134	5.275591	159	6.259843
10	0.393701	35	1.377953	60	2.362205	85	3.346457	110	4.330709	135	5.314961	160	6.299213
11	0.433071	36	1.417323	61	2.401575	86	3.385827	111	4.370079	136	5.354331	161	6.338583
12	0.472441	37	1.456693	62	2.440945	87	3.425197	112	4.409449	137	5.393701	162	6.377953
13	0.511811	38	1.496063	63	2.480315	88	3.464567	113	4.448819	138	5.433071	163	6.417323
14	0.551181	39	1.535433	64	2.519685	89	3.503937	114	4.488189	139	5.472441	164	6.456693
15	0.590551	40	1.574803	65	2.559055	90	3.543307	115	4.527559	140	5.511811	165	6.496063
16	0.629921	41	1.614173	66	2.598425	91	3.582677	116	4.566929	141	5.551181	166	6.535433
17	0.669291	42	1.653543	67	2.637795	92	3.622047	117	4.606299	142	5.590551	167	6.574803
18	0.708661	43	1.692913	68	2.677165	93	3.661417	118	4.645669	143	5.629921	168	6.614173
19	0.748031	44	1.732283	69	2.716535	94	3.700787	119	4.685039	144	5.669291	169	6.653543
20	0.787402	45	1.771654	70	2.755906	95	3.740157	120	4.724410	145	5.708662	170	6.692914
21	0.826772	46	1.811024	71	2.795276	96	3.779528	121	4.763780	146	5.748032	171	6.732284
22	0.866142	47	1.850394	72	2.834646	97	3.818898	122	4.803150	147	5.787402	172	6.771654
23	0.905512	48	1.889764	73	2.874016	98	3.858268	123	4.842520	148	5.826772	173	6.811024
24	0.944882	49	1.929134	74	2.913386	99	3.897638	124	4.881890	149	5.866142	174	6.850394
25	0.984252	50	1.968504	75	2.952756	100	3.937008	125	4.921260	150	5.905512	175	6.889764
												180	7.074016

Chute Lining and Skirtboard Rubber

Super RINOHIDE® 7160

- Made of specially compounded SBR to withstand severe impact and abrasion
- Suitable for chute lining, skirtboards, belt wipers, impact pads, scraper stock, bumper pads, tumbler liners, and sand and shot curtains

Tan Gum Style 135

- Made of pure gum rubber for highest tensile strength
- Ideal for skirtboard, bumper stock, laundry lining, sand and shot blast curtains, scraper stock and tumbler liners

Style 7164

- Made of SBR with optional duck fabric backing available on minimum quantity orders
- Most suitable for chute lining as well as belt wipers and laundry lining

Extruded Skirtboard Rubber

- Tough SBR construction
- Ideal for seals on skirtboard to help prevent spillage and contain loads on conveyor systems

CAUTION: Strips of old rubber belting should never be used for edging skirtboards, since the fabric will pick up and retain abrasive particles which will abrade the belt cover.

Product	Elastomer	Color	Finish	Durometer (Shore A)	Width* (Inches)	Stock Gauge* (inches)	Approx. Weight (lbs./sq.yd, 1/4" thick)	Temp Range	Typical & (Minimum) Tensile (psi)	Ultimate Elongation (% min.)
Super RINOHIDE™	SBR	Black	Smooth	55-65	48	1/8, 1/4, 3/8, 1/2, 3/4, 1	1.5	-20°F to +200°F	2,800 (2,500)	500
Tan Gum Style 135	Natural	Tan	Smooth	35-45	36, 48	1/4, 3/8, 1/2, 3/4, 1	1.28	-20°F to +180°F	3,400 (3,000)	600
Style 7164	SBR	Black	Smooth	55-65	48	1/8, 1/4, 3/8, 1/2, 3/4, 1	1.70	-20°F to +200°F	2,400 (2,000)	300
Extruded Skirtboard	SBR	Black	Smooth	55-65	4, 5, 6, 8, 10, 12	1/4, 3/8, 1/2, 3/4, 1	1.62	-20°F to +180°F	1,800 (1,500)	300

Conveyor System Components

Belt Roll Diameters Based on 8" Core Diameters

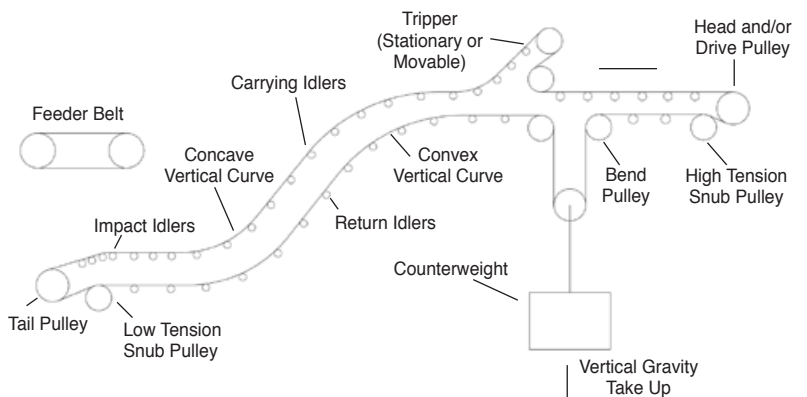
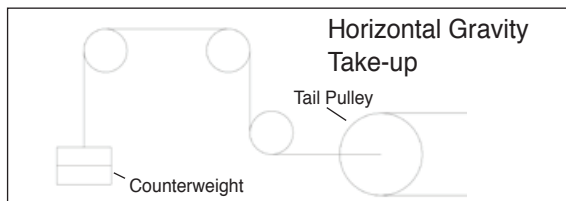
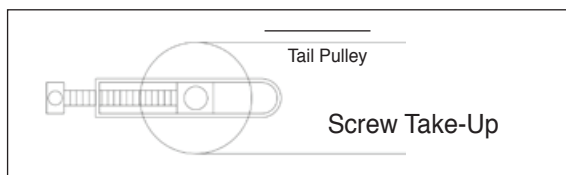
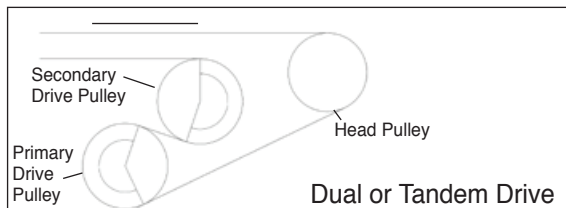
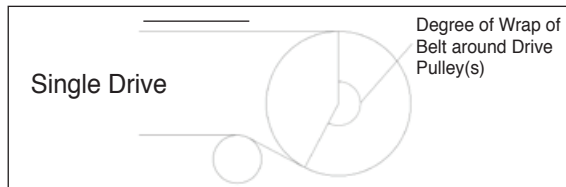
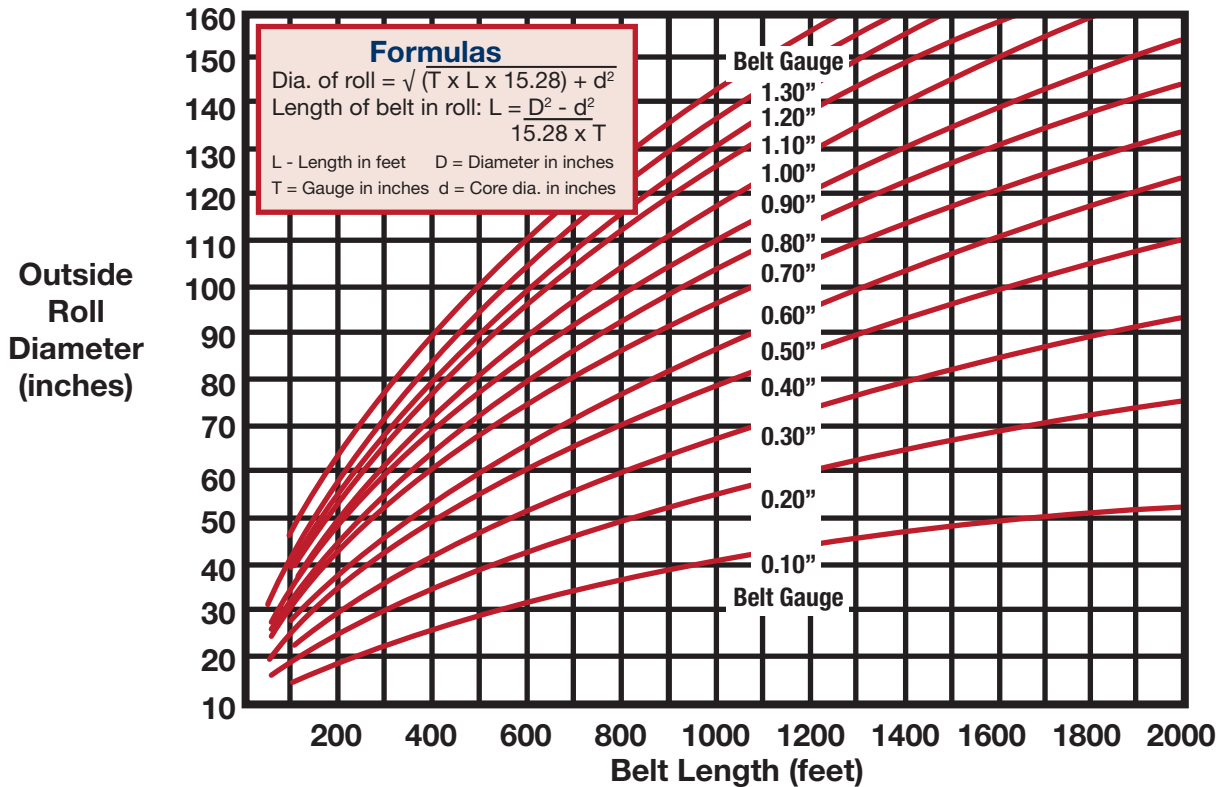

More than just great products...

Beyond offering you a wide range of rubber, conveying and sealing, GRT enhances the value of its products with technical services and comprehensive training programs:

- A global network of stocking Authorized GRT Rubber Technologies Distributors.
- Factory sales representatives and applications engineers available for problem solving when and where it is needed.
- Toll-free 800 telephone and fax numbers for immediate product information.
- In-plant surveys of equipment and processes, providing the customer with recommendations to identify and eliminate conveying and sealing problems before they start.
- The most sophisticated and most comprehensive test facilities available.
- Technical field seminars on all GRT products
- Factory-sponsored product training programs, including hands-on seminars, to ensure that GRT representatives and their distributor personnel are the best in the industry.
- Technical Bulletins to keep you up-to-date on product enhancements and changes.

Customers who specify GRT Rubber Technologies products get, at no extra cost, the high quality support needed to run a profitable operation.



GRT Rubber Technologies
201 Dana Drive
Paragould, AR 72450, USA
Phone: 1-800-643-0134
Fax: 1.800.325.0506

www.grtrubber.com

WARNING:

Properties/applications shown throughout this brochure are typical. Your specific application should not be undertaken without independent study and evaluation for suitability. For specific application recommendations consult GRT.

Performance data published in this brochure has been developed from field testing, customer field reports and/or in-house testing.

While the utmost care has been used in compiling this brochure, we assume no responsibility for errors. Specifications subject to change without notice. This edition cancels all previous issues. Subject to change without notice.

GRT is a registered trademark for engineered sheet rubber products.

GOODYEAR
RUBBER PRODUCTS, INC.

 **727-342-5088**

You can also email us at
GRP@goodyearrubberproducts.com