

# PROCO

*The Expansion Joint and Check Valve People*



RUBBER EXPANSION JOINT SERIES 230

**GOODYEAR**  
RUBBER PRODUCTS, INC.

☎ 727-342-5088

You can also email us at  
[GRP@goodyearrubberproducts.com](mailto:GRP@goodyearrubberproducts.com)

# Proco Series 230 Rubber Joints

**Proco Series 230** Rubber Expansion Joints are designed for piping systems to absorb pipe movements, relieve stress, reduce system noise/vibration, compensate for misalignment/offset and to protect rotating mechanical equipment against start-up surge forces.

**The Style 231 and FA231:** Single wide-arch product and work horse for industrial applications available in open arch and filled arch configurations.

**The Style 232 and FA232:** Double wide-arch product where more movement is needed. Available in open arch and filled arch configurations.

**The Style 233 and FA233:** Triple wide-arch product where most movement is needed. Available in open arch and filled arch configurations.

## Features and Benefits:

### Absorbs Directional Movement

Thermal movements appear in any rigid pipe system due to temperature changes. The Series 230 wide arch expansion joints allow for axial compression or axial extension, lateral deflection as well as angular and torsional movements. (Note: Rated movements in this publication are based on one plane movements. Multiple movement conditions are based on a multiple movement calculation.)

### Less Turbulence or Material Entrapment

The Series 230 expansion joints are manufactured with the integral rubber flange joining the body at a true 90° angle. This ensures the product will install snug against the mating pipe flange free of voids creating less turbulence in the pipe system. The Series 230 is also available with a filled arch for applications that have 20% or more solids in the process.

### Absorbs Vibration, Noise and Shock

The Proco Series 230 rubber expansion joints effectively dampen and insulate downstream piping against the transmission of noise and vibration generated by mechanical equipment. Noise and vibrations caused by equipment can cause stress in pipe, pipe guides, anchors and other equipment downstream. The Series 230 expansion joints will help relieve noise and vibration occurrences in a pipe system. Water hammer and pumping impulses can also cause strain, stress or shock to a piping system. Install the Series 230 to help compensate for these system pressure spikes.

### Compensates for Misalignment

Rubber expansion joints are commonly used by contractors and plant personnel to allow for slight pipe misalignment during installation of new piping and or replacement applications. (Although rubber expansion joints can be made with permanent offsets, it is suggested that piping misalignments be limited to no more than 1/8" per the Fluid Sealing Association Piping Expansion Technical Handbook [www.fluidsealing.com](http://www.fluidsealing.com).)

### Wide Service Range and Less Weight

Engineered to operate up to 200 PSIG (nominal size dependent) Or up to 250°F (elastomer dependent), the Series 230 can be specified for a wide range of piping system requirements. The Series 230 rubber expansion joints are constructed in various elastomers with rubber impregnated polyester tire cord and reinforced with wire to create a product with greater operating performance.

### Material Identification

All Series 230 expansion joints are strip branded with cure dates and elastomer designations.

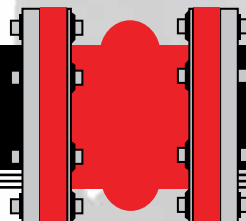
All Neoprene Tube/Neoprene Cover (NN) and Nitrile Tube/Neoprene Cover (NP) elastomer designated joints meet the Coast Guard Requirements and conform to ASTM F 1123-87. EE-NSF/61 - ANSI/NSF Standard 61 standards were developed by the National Sanitation Foundation (NSF), and the American National Standards Institute (ANSI) and relates to water treatment which establishes stringent requirements for the control of equipment that comes in contact with either potable water or products that support the production of potable water



### Large Inventory

Proco Products, Inc. maintains one of the largest inventories of rubber expansion joints in the world. Please contact us for price and availability.

**Protecting Piping and Equipment Systems from Stress/Motion**



Information subject to change without notice.

**Table 1: Available Materials • Temperatures**

For Specific Chemical Compatibilities, See: PROCO "Chemical To Elastomer Guide"					
Material Code	Cover <sup>1,2</sup> Elastomer	Tube <sup>1,2</sup> Elastomer	Maximum Operating Temp. °F (°C)	Branding Label Color	F.S.A. Material Class
<b>BB</b>	Chlorobutyl	Chlorobutyl	250° (121°)	Black	STD. III
<b>EE</b>	EPDM	EPDM	250° (121°)	Red	STD. III
<b>EE-NSF61<sup>6</sup></b>	EPDM	EPDM	250° (121°)	Red	STD. III
<b>EQ</b>	EPDM	FDA-EPDM	250° (121°)	Red <sup>3</sup>	STD. II
<b>NH</b>	Neoprene	CSM	212° (100°)	Green	STD. II
<b>NN</b>	Neoprene	Neoprene	225° (107°)	Blue	STD. II
<b>NF</b>	Neoprene	FDA-Neoprene	225° (107°)	Blue <sup>3</sup>	STD. II
<b>NP</b>	Neoprene	Nitrile	212° (100°)	Yellow	STD. II
<b>NR</b>	Neoprene	Natural Rubber	180° (82°)	White	STD. I
<b>NG</b>	Neoprene	Natural Gum	180° (82°)	Tan	STD. I

Notes: All Products are reinforced with Polyester Tire Cord  
 1. Expansion Joint "Cover" can be coated with CSM UV Resistant Coating.  
 2. All NN & NP elastomer designated joints meet the Coast Guard Requirements

# Style 231 Performance Data

**Table 2: Sizes • Movements • Design Pressures • Weights**

Expansion Joint Size Nom. I.D. Inch / (mm)		Neutral <sup>10</sup> Length Inch / (mm)		231 Movement Capability: <sup>1, 2</sup> From Neutral Position (Non-Concurrent)					Operating Conditions <sup>3</sup>			Weights lbs / (kgs) <sup>4</sup>				
				Axial Compression Inch / (mm)	Axial Extension Inch / (mm)	Lateral Deflection Inch / (mm)	Angular Deflection <sup>5</sup> (Degrees)	Torsional Rotation <sup>6</sup> (Degrees)	Thrust Factor <sup>7</sup> In <sup>2</sup> / (cm <sup>2</sup> )	Positive PSIG (Bar)	Vacuum Inches of Hg / (mm of Hg) <sup>8</sup>	Expansion Joint	Retaining Ring Set	Control Rod Assembly <sup>9</sup>		
<b>1</b>	(25)	<b>6</b>	(152)	<b>0.6</b> (20)	<b>0.4</b> (10)	<b>0.5</b> (12)	<b>50.4</b>	<b>2</b>	<b>5.31</b> (35)	<b>200</b> (14)	<b>26</b> (660)	<b>2.0</b> (0.8)	<b>2.0</b> (0.8)	<b>2.3</b> (1.0)		
<b>1.25</b>	(32)	<b>6</b>	(152)	<b>0.8</b> (20)	<b>0.4</b> (10)	<b>0.5</b> (12)	<b>43.1</b>	<b>2</b>	<b>6.38</b> (42)	<b>200</b> (14)	<b>26</b> (660)	<b>2.5</b> (1.1)	<b>2.5</b> (1.1)	<b>2.3</b> (1.0)		
<b>1.5</b>	(40)	<b>6</b>	(152)	<b>0.8</b> (20)	<b>0.4</b> (10)	<b>0.5</b> (12)	<b>38.1</b>	<b>2</b>	<b>7.55</b> (49)	<b>200</b> (14)	<b>26</b> (660)	<b>3.0</b> (1.4)	<b>2.5</b> (1.1)	<b>2.3</b> (1.0)		
<b>2</b>	(50)	<b>6</b>	(152)	<b>1.4</b> (35)	<b>0.7</b> (17)	<b>0.6</b> (16)	<b>34.2</b>	<b>2</b>	<b>12.57</b> (81)	<b>200</b> (14)	<b>26</b> (660)	<b>4.0</b> (1.8)	<b>4.0</b> (1.8)	<b>2.8</b> (1.3)		
		<b>7</b>	(178)													
		<b>8</b>	(203)													
		<b>9</b>	(229)													
<b>2.5</b>	(65)	<b>6</b>	(152)	<b>1.4</b> (35)	<b>0.7</b> (17)	<b>0.6</b> (16)	<b>27.6</b>	<b>2</b>	<b>15.90</b> (103)	<b>200</b> (14)	<b>26</b> (660)	<b>4.5</b> (2.0)	<b>4.5</b> (2.0)	<b>2.8</b> (1.3)		
		<b>7</b>	(178)													
		<b>8</b>	(203)													
		<b>9</b>	(229)													
<b>3</b>	(80)	<b>6</b>	(152)	<b>1.4</b> (35)	<b>0.7</b> (17)	<b>0.6</b> (16)	<b>23.0</b>	<b>2</b>	<b>19.64</b> (127)	<b>200</b> (14)	<b>26</b> (660)	<b>5.5</b> (2.5)	<b>5.5</b> (2.5)	<b>2.8</b> (1.3)		
		<b>7</b>	(178)													
		<b>8</b>	(203)													
		<b>9</b>	(229)													
<b>4</b>	(100)	<b>6</b>	(152)	<b>1.4</b> (35)	<b>0.7</b> (17)	<b>0.6</b> (16)	<b>18.8</b>	<b>2</b>	<b>28.27</b> (182)	<b>200</b> (14)	<b>26</b> (660)	<b>8.0</b> (3.6)	<b>8.0</b> (3.6)	<b>2.8</b> (1.3)		
		<b>7</b>	(178)													
		<b>8</b>	(203)													
		<b>9</b>	(229)													
<b>5</b>	(125)	<b>6</b>	(152)	<b>1.6</b> (40)	<b>0.8</b> (20)	<b>0.7</b> (18)	<b>15.2</b>	<b>2</b>	<b>43.01</b> (277)	<b>190</b> (13)	<b>26</b> (660)	<b>9.0</b> (4.1)	<b>8.5</b> (3.9)	<b>4.0</b> (1.8)		
		<b>7</b>	(178)													
		<b>8</b>	(203)													
		<b>9</b>	(229)													
		<b>10</b>	(254)													
		<b>12</b>	(305)													

# Style 231 Performance Data continued...

**Table 2: Sizes • Movements • Design Pressures • Weights**

Expansion Joint Size Nom. I.D. Inch / (mm)		Neutral <sup>10</sup> Length Inch / (mm)		231 Movement Capability: <sup>1, 2</sup> From Neutral Position (Non-Concurrent)					Operating Conditions <sup>3</sup>			Weights lbs / (kgs) <sup>4</sup>		
				Axial Compression Inch / (mm)	Axial Extension Inch / (mm)	Lateral Deflection Inch / (mm)	Angular Deflection <sup>5</sup> (Degrees)	Torsional Rotation <sup>6</sup> (Degrees)	Thrust Factor <sup>7</sup> In <sup>2</sup> / (cm <sup>2</sup> )	Positive PSIG (Bar)	Vacuum Inches of Hg / (mm of Hg) <sup>8</sup>	Expansion Joint	Retaining Ring Set	Control Rod Assembly <sup>9</sup>
6	(150)	6	(152)	1.6 (40)	0.8 (20)	0.7 (18)	12.8	2	55.42 (358)	190 (13)	26 (660)	11.0 (5.0)	9.5 (4.3)	4.0 (1.8)
		7	(178)											
		8	(203)											
		9	(229)											
		10	(254)											
8	(200)	6	(152)	1.6 (40)	0.8 (20)	0.7 (18)	9.7	2	89.95 (580)	190 (13)	26 (660)	15.0 (6.8)	14.5 (6.6)	8.0 (3.6)
		7	(178)											
		8	(203)											
		9	(229)											
		10	(254)											
10	(250)	8	(203)	1.6 (40)	0.8 (20)	0.7 (18)	9.1	2	120.76 (779)	190 (13)	26 (660)	23.0 (10.4)	17.0 (7.7)	10.0 (4.5)
		9	(229)											
		10	(254)											
		12	(305)											
		14	(356)											
12	(300)	8	(203)	1.6 (40)	0.8 (20)	0.8 (20)	7.6	2	172.03 (1110)	190 (13)	26 (660)	34.0 (15.4)	24.5 (11.0)	10.0 (4.5)
		9	(229)											
		10	(254)											
		12	(305)											
		14	(356)											
14	(350)	8	(203)	1.6 (40)	0.8 (20)	0.8 (20)	6.5	2	221.67 (1430)	130 (9.0)	26 (660)	40.0 (18.1)	27.0 (12.3)	12.0 (5.4)
		9	(229)											
		10	(254)											
		12	(305)											
		14	(356)											
16	(400)	8	(203)	1.6 (40)	0.8 (20)	0.8 (20)	5.7	2	277.59 (1791)	115 (8.0)	26 (660)	47.0 (21.3)	33.5 (15.2)	15.0 (6.8)
		9	(229)											
		10	(254)											
		12	(305)											
		14	(356)											
18	(450)	8	(203)	1.6 (40)	0.8 (20)	0.8 (20)	5.1	2	339.80 (2192)	115 (8.0)	26 (660)	56.0 (25.4)	34.0 (15.5)	16.0 (7.2)
		9	(229)											
		10	(254)											
		12	(305)											
		14	(356)											
20	(500)	8	(203)	1.6 (40)	0.8 (20)	0.8 (20)	5.7	2	408.28 (2634)	115 (8.0)	26 (660)	67.0 (30.4)	38.0 (17.3)	16.0 (7.2)
		9	(229)											
		10	(254)											
		12	(305)											
		14	(356)											

**Table 2: Sizes • Movements • Design Pressures • Weights**

Expansion Joint Size Nom. I.D. Inch / (mm)		Neutral <sup>10</sup> Length Inch / (mm)		231 Movement Capability: <sup>1, 2</sup> From Neutral Position (Non-Concurrent)					Operating Conditions <sup>3</sup>			Weights lbs / (kgs) <sup>4</sup>		
				Axial Compression Inch / (mm)	Axial Extension Inch / (mm)	Lateral Deflection Inch / (mm)	Angular Deflection <sup>5</sup> (Degrees)	Torsional Rotation <sup>6</sup> (Degrees)	Thrust Factor <sup>7</sup> In <sup>2</sup> / (cm <sup>2</sup> )	Positive PSIG (Bar)	Vacuum Inches of Hg / (mm of Hg) <sup>8</sup>	Expansion Joint	Retaining Ring Set	Control Rod Assembly <sup>9</sup>
22	(550)	10	(254)	2.0 (50)	1.0 (25)	0.9 (23)	5.2	2	498.76 (3218)	100 (7.0)	26 (660)	70.0 (31.8)	44.0 (20.0)	19.0 (8.6)
		12	(305)											
		14	(356)											
24	(600)	10	(254)	2.0 (50)	1.0 (25)	0.9 (23)	4.8	2	581.76 (3749)	100 (7.0)	26 (660)	79.0 (35.8)	48.0 (21.8)	20.0 (9.0)
		12	(305)											
		14	(356)											
26	(650)	10	(254)	2.0 (50)	1.0 (25)	0.9 (23)	4.4	2	669.66 (4320)	90 (6.0)	26 (660)	100.0 (45.4)	51.0 (23.1)	20.0 (9.0)
		12	(305)											
		14	(356)											
28	(700)	10	(254)	2.0 (50)	1.0 (25)	0.9 (23)	4.1	2	764.54 (4933)	90 (6.0)	26 (660)	102.0 (46.3)	55.0 (25.0)	28.0 (12.6)
		12	(305)											
		14	(356)											
30	(750)	10	(254)	2.0 (50)	1.0 (25)	0.9 (23)	2.2	2	865.70 (5585)	90 (6.0)	26 (660)	117.0 (53.1)	63.0 (28.6)	29.5 (13.3)
		12	(305)											
		14	(356)											
32	(800)	10	(254)	2.0 (50)	1.0 (25)	0.9 (23)	3.6	2	973.14 (6278)	90 (6.0)	26 (660)	120.0 (54.4)	68.0 (30.8)	33.0 (14.9)
		12	(305)											
		14	(356)											
34	(850)	10	(254)	2.0 (50)	1.0 (25)	0.9 (23)	3.4	2	1086.87 (7012)	90 (6.0)	26 (660)	122.0 (55.3)	72.0 (32.7)	43.0 (19.5)
		12	(305)											
		14	(356)											
36	(900)	10	(254)	2.0 (50)	1.0 (25)	0.9 (23)	3.2	2	1206.87 (7786)	90 (6.0)	26 (660)	143.0 (64.9)	76.0 (34.5)	43.0 (19.5)
		12	(305)											
		14	(356)											
38	(950)	10	(254)	2.0 (50)	1.0 (25)	0.9 (23)	3.0	2	1333.16 (8601)	90 (6.0)	26 (660)	162.0 (73.5)	86.0 (39.0)	43.0 (19.5)
		12	(305)											
		14	(356)											
40	(1000)	10	(254)	2.0 (50)	1.0 (25)	0.9 (23)	2.9	2	1465.74 (9456)	90 (6.0)	26 (660)	173.0 (78.5)	100.0 (45.5)	43.0 (19.5)
		12	(305)											
		14	(356)											
42	(1050)	12	(305)	2.4 (60)	1.2 (30)	1.1 (28)	3.3	2	1661.90 (10722)	80 (5.5)	26 (660)	193.0 (87.5)	100.0 (45.5)	44.0 (20.0)
		14	(356)											
44	(1100)	12	(305)	2.4 (60)	1.2 (30)	1.1 (28)	3.1	2	1809.56 (11675)	80 (5.5)	26 (660)	198.0 (89.8)	104.0 (37.2)	44.0 (20.0)
		14	(356)											
46	(1150)	12	(305)	2.4 (60)	1.2 (30)	1.1 (28)	3.0	2	1963.50 (12668)	80 (5.5)	26 (660)	205.0 (93.0)	127.0 (57.6)	44.0 (20.0)
		14	(356)											

# Style 231 Performance Data continued...

Table 2: Sizes • Movements • Design Pressures • Weights														
Expansion Joint Size Nom. I.D. Inch / (mm)		Neutral <sup>10</sup> Length Inch / (mm)		231 Movement Capability: <sup>1, 2</sup> From Neutral Position (Non-Concurrent)					Operating Conditions <sup>3</sup>			Weights lbs / (kgs) <sup>4</sup>		
				Axial Compression Inch / (mm)	Axial Extension Inch / (mm)	Lateral Deflection Inch / (mm)	Angular Deflection <sup>5</sup> (Degrees)	Torsional Rotation <sup>6</sup> (Degrees)	Thrust Factor <sup>7</sup> In <sup>2</sup> / (cm <sup>2</sup> )	Positive PSIG (Bar)	Vacuum Inches of Hg / (mm of Hg) <sup>8</sup>	Expansion Joint	Retaining Ring Set	Control Rod Assembly <sup>9</sup>
<b>48</b>	(1200)	<b>12</b>	(305)	2.4	1.2	1.1	2.9	2	2123.72	80	26	211.0	132.0	44.0
		<b>14</b>	(356)	(60)	(30)	(28)			(13700)	(5.5)	(660)	(95.7)	(59.9)	(20.0)
<b>50</b>	(1250)	<b>12</b>	(305)	2.4	1.2	1.1	2.8	2	2290.72	80	26	240.0	134.0	44.0
		<b>14</b>	(356)	(60)	(30)	(28)			(14776)	(5.5)	(660)	(108.8)	(60.0)	(20.0)
<b>52</b>	(1300)	<b>12</b>	(305)	2.4	1.2	1.1	2.6	2	2463.00	80	26	256.0	136.0	60.0
		<b>14</b>	(356)	(60)	(30)	(28)			(15890)	(5.5)	(660)	(116.1)	(61.7)	(27.0)
<b>54</b>	(1350)	<b>12</b>	(305)	2.4	1.2	1.1	2.6	2	2715.47	80	26	265.0	150.0	63.0
		<b>14</b>	(356)	(60)	(30)	(28)			(17519)	(5.5)	(660)	(120.1)	(68.0)	(28.6)
<b>56</b>	(1400)	<b>12</b>	(305)	2.4	1.2	1.1	2.5	2	2903.33	80	26	288.0	165.0	63.0
		<b>14</b>	(356)	(60)	(30)	(28)			(18731)	(5.5)	(660)	(130.6)	(70.8)	(28.6)
<b>58</b>	(1450)	<b>12</b>	(305)	2.4	1.2	1.1	2.4	2	3097.48	80	26	300.0	190.0	66.2
		<b>14</b>	(356)	(60)	(30)	(28)			(19984)	(5.5)	(660)	(136.1)	(86.2)	(30.0)
<b>60</b>	(1500)	<b>12</b>	(305)	2.4	1.2	1.1	2.3	2	3297.92	80	26	310.0	200.0	68.3
		<b>14</b>	(356)	(60)	(30)	(28)			(21277)	(5.5)	(660)	(140.6)	(90.7)	(31.2)
<b>66</b>	(1650)	<b>12</b>	(305)	2.4	1.2	1.1	2.1	2	3936.92	80	26	350.0	240.0	71.0
		<b>14</b>	(356)	(60)	(30)	(28)			(25399)	(5.5)	(660)	(158.7)	(108.8)	(32.2)
<b>68</b>	(1700)	<b>12</b>	(305)	2.4	1.2	1.1	2.0	2	4162.48	70	26	368.8	227.0	76.3
		<b>14</b>	(356)	(60)	(30)	(28)			(26855)	(5.0)	(660)	(166.9)	(103.0)	(34.6)
<b>72</b>	(1800)	<b>12</b>	(305)	2.4	1.2	1.1	1.9	2	4632.47	70	26	390.0	290.0	87.0
		<b>14</b>	(356)	(60)	(30)	(28)			(29887)	(5.0)	(660)	(176.9)	(131.5)	(39.4)
<b>78</b>	(1950)	<b>12</b>	(305)	2.3	1.2	1.1	1.8	2	5410.60	85	26	410.0	315.0	103.0
		<b>14</b>	(356)	(57)	(30)	(28)			(34907)	(6.0)	(660)	(186.0)	(142.9)	(46.7)
<b>84</b>	(2100)	<b>12</b>	(305)	2.3	1.2	1.1	1.6	2	6221.13	85	26	440.0	350.0	113.0
		<b>14</b>	(356)	(57)	(30)	(28)			(40136)	(6.0)	(660)	(200.0)	(158.0)	(51.3)
<b>90</b>	(2250)	<b>12</b>	(305)	2.3	1.2	1.1	1.6	2	7088.11	85	26	448.0	363.0	125.0
		<b>14</b>	(356)	(57)	(30)	(28)			(45730)	(6.0)	(660)	(203.1)	(164.6)	(56.7)
<b>96</b>	(2400)	<b>12</b>	(305)	2.3	1.2	1.1	1.4	2	8011.85	85	26	466.0	367.0	125.0
		<b>14</b>	(356)	(57)	(30)	(28)			(51689)	(6.0)	(660)	(211.3)	(170.5)	(56.7)
<b>102</b>	(2550)	<b>12</b>	(305)	2.3	1.2	1.1	1.3	2	8992.02	85	26	485.8	395.0	137.0
		<b>14</b>	(356)	(57)	(30)	(28)			(58013)	(6.0)	(660)	(220.0)	(179.1)	(62.1)
<b>108</b>	(2700)	<b>12</b>	(305)	2.3	1.2	1.1	1.2	2	10028.75	85	26	510.0	425.0	139.0
		<b>14</b>	(356)	(57)	(30)	(28)			(64702)	(6.0)	(660)	(231.3)	(192.7)	(63.0)
<b>120</b>	(3000)	<b>12</b>	(305)	2.3	1.2	1.1	1.1	2	12271.84	85	26	540.0	565.0	151.0
		<b>14</b>	(356)	(57)	(30)	(28)			(79173)	(6.0)	(660)	(244.9)	(256.2)	(65.8)

Neutral lengths in RED are the recommended minimum lengths.

Metric Conversion Formula: Nominal I.D. : in. x 25 = mm; Neutral length: in. x 25.4 = mm

NOTES:

1. **Concurrent Movements** - Concurrent movements are developed when two or more movements in a pipe system occur at the same time. If multiple movements exceed single arch design there may be a need for additional arches. To perform calculation for concurrent movement when a pipe system design has more than one movement, please use the following formula:  
$$\frac{\text{Actual Axial Compression} + \text{Actual Axial Extension} + \text{Actual Lateral (X)} + \text{Actual Lateral (Y)}}{\text{Rated Axial Compression} + \text{Rated Axial Extension} + \text{Rated Lateral (X)} + \text{Rated Lateral (Y)}} = / < 1$$
Calculation must be equal to or less than 1 for expansion joint to operate within concurrent movement capability.
2. **Filled Arch Rubber Expansion Joints** - Known as Style FA 231. The Series FA230 rubber expansion joints should be selected when there are 20% or more solids being conveyed in the pipe system. The filled arch products are manufactured with seamless tube filled with a lower durometer rubber in the arch core. The filled arch product will have a 50% reduced movement capability from the information provided in Table 2.
3. Pressure rating is based on 170° F operating temperature with a 4:1 safety factor. At higher temperatures, the pressure rating is reduced slightly. Hydrostatic testing at 1.5 times rated maximum catalogue pressure or design working pressure of pipe system for 10 minutes is available upon request.
4. Weights are approximate and vary due to length.
5. The degree of angular movement is based on the maximum rated extension.
6. Torsional movement is expressed when the expansion joint is at neutral length.
7. **Calculation of Thrust (Thrust Factor)**. When expansion joints are installed in the pipeline, the static portion of the thrust is calculated as a product of the area of the I.D. of the arch of the expansion joint times the maximum pressure (design, test or surge) that will occur in the line. The result is a force expressed in pounds.  
**Take Design, surge or test pressure X thrust factor to calculate end thrust.**
8. Parts listed at 26" Hg / 660 mm Hg vacuum have a design rating of 30" Hg / 762 mm Hg (full vacuum). Vacuum rating is based on neutral installed length, without external load. Products should not be installed "extended" on vacuum applications.
9. Limit rod unit weight consists of one rod with washers, nuts and two limit rod plates. Multiply number of limit rods needed for the application (as specified in the Fluid Sealing Association's Technical Handbook, Seventh Edition or table 4 in this manual) to determine correct weights.
10. Shorter neutral lengths available in style 221 for sizes 10", 12", 24" & 30".

"Effective Area"

Thrust Factor=

$$T = \frac{\pi}{4} (D)^2 (P)$$

T= Thrust  
P= PSI (Design, Test or Surge)  
D= Arch I.D.



# Style 232 Performance Data

**Table 3: Sizes • Movements • Design Pressures • Weights**

Expansion Joint Size Nom. I.D. Inch / (mm)		Neutral Length Inch / (mm)		232 Movement Capability: <sup>1, 2</sup> From Neutral Position (Non-Concurrent)					Operating Conditions <sup>3</sup>			Weights lbs / (kgs) <sup>4</sup>		
				Axial Compression Inch / (mm)	Axial Extension Inch / (mm)	Lateral Deflection Inch / (mm)	Angular Deflection <sup>5</sup> (Degrees)	Torsional Rotation <sup>6</sup> (Degrees)	Thrust Factor <sup>7</sup> In <sup>2</sup> / (cm <sup>2</sup> )	Positive PSIG (Bar)	Vacuum Inches of Hg / (mm of Hg) <sup>8</sup>	Expansion Joint	Retaining Ring Set	Control Rod Assembly <sup>9</sup>
1.5	(40)	10	(254)	1.6 (40)	0.8 (20)	0.9 (24)	58.0	2	7.44 (48)	200 (14.0)	26 (660)	3.0 (1.4)	2.5 (1.1)	2.3 (1.0)
2	(50)	10	(254)	2.8 (70)	1.4 (35)	1.2 (32)	58.0	2	12.40 (80)	200 (14.0)	26 (660)	4.0 (1.8)	4.0 (1.8)	2.8 (1.3)
2.5	(65)	10	(254)	2.8 (70)	1.4 (35)	1.2 (32)	47.4	2	15.66 (101)	200 (14.0)	26 (660)	4.5 (2.0)	4.5 (2.0)	2.8 (1.3)
3	(80)	10	(254)	2.8 (70)	1.4 (35)	1.2 (32)	42.2	2	19.36 (125)	200 (14.0)	26 (660)	6.0 (2.7)	5.5 (4.3)	2.8 (1.3)
4	(100)	10	(254)	2.8 (70)	1.4 (35)	1.2 (32)	34.2	2	27.90 (180)	200 (14.0)	26 (660)	8.5 (3.9)	8.0 (3.6)	2.8 (1.3)
5	(125)	10	(254)	3.2 (80)	1.6 (40)	1.4 (36)	28.6	2	38.13 (246)	190 (13.0)	26 (660)	9.5 (4.3)	8.5 (3.9)	4.0 (1.8)
6	(150)	10 12	(254) (305)	3.2 (80)	1.6 (40)	1.4 (36)	24.4	2	49.91 (322)	190 (13.0)	26 (660)	11.5 (5.2)	9.5 (4.3)	4.0 (1.8)
8	(200)	10 12	(254) (305)	3.2 (80)	1.6 (40)	1.4 (36)	18.8	2	77.97 (503)	190 (13.0)	26 (660)	16.0 (7.3)	14.5 (6.6)	8.0 (3.6)
10	(250)	14	(356)	3.2 (80)	1.6 (40)	1.4 (36)	17.8	2	119.97 (774)	190 (13.0)	26 (660)	29.0 (13.2)	17.0 (7.7)	10.0 (4.5)
12	(300)	14	(356)	3.2 (80)	1.6 (40)	1.6 (40)	14.9	2	161.98 (1045)	190 (13.0)	26 (660)	36.0 (16.3)	24.5 (11.0)	10.0 (4.5)
14	(350)	14 16	(356) (406)	3.2 (80)	1.6 (40)	1.6 (40)	12.9	2	210.18 (1356)	130 (9.0)	26 (660)	44.0 (20.0)	27.0 (12.3)	12.0 (5.4)
16	(400)	14 16	(356) (406)	3.2 (80)	1.6 (40)	1.6 (40)	11.3	2	264.74 (1708)	115 (8.0)	26 (660)	53.0 (24.0)	33.5 (15.2)	15.0 (6.8)
18	(450)	14 16	(356) (406)	3.2 (80)	1.6 (40)	1.6 (40)	10.1	2	325.50 (2100)	115 (8.0)	26 (660)	61.0 (27.7)	34.0 (15.5)	16.0 (7.2)
20	(500)	14 16	(356) (406)	3.2 (80)	1.6 (40)	1.6 (40)	9.1	2	392.62 (2533)	115 (8.0)	26 (660)	73.0 (33.1)	38.0 (17.2)	16.0 (7.2)
24	(600)	16	(406)	4.0 (100)	2.0 (50)	1.8 (46)	9.5	2	562.03 (3626)	100 (7.0)	26 (660)	88.0 (40.0)	48.0 (21.8)	20.0 (9.1)
30	(750)	16	(406)	4.0 (102)	2.0 (50)	1.8 (46)	7.6	2	842.27 (5434)	90 (6.0)	26 (660)	127.0 (57.6)	63.0 (28.6)	29.5 (13.3)
34	(850)	16	(406)	4.0 (102)	2.0 (50)	1.8 (46)	6.7	2	1060.51 (6842)	90 (6.0)	26 (660)	134.8 (60.8)	72.0 (32.7)	43.0 (19.5)
36	(900)	16	(406)	4.0 (102)	2.0 (50)	1.8 (46)	6.3	2	1179.09 (7607)	90 (6.0)	26 (660)	156.0 (70.8)	76.0 (34.5)	45.0 (20.4)
42	(1050)	16	(406)	4.8 (120)	2.4 (60)	2.2 (56)	6.5	2	1628.28 (10505)	80 (5.5)	26 (660)	211.0 (95.7)	100.0 (45.4)	47.0 (21.3)
48	(1200)	16	(406)	4.8 (120)	2.4 (60)	2.2 (56)	5.7	2	2085.53 (13455)	80 (5.5)	26 (660)	222.8 (101.0)	132.0 (59.9)	49.0 (22.2)

Neutral lengths in RFD are the recommended minimum lengths



**Table 3: Sizes • Movements • Design Pressures • Weights**

Expansion Joint Size Nom. I.D. Inch / (mm)		Neutral Length Inch / (mm)		232 Movement Capability: 1, 2 From Neutral Position (Non-Concurrent)					Operating Conditions 3			Weights lbs / (kgs) 4		
				Axial Compression Inch / (mm)	Axial Extension Inch / (mm)	Lateral Deflection Inch / (mm)	Angular Deflection 5 (Degrees)	Torsional Rotation 6 (Degrees)	Thrust Factor 7 In <sup>2</sup> / (cm <sup>2</sup> )	Positive PSIG (Bar)	Vacuum Inches of Hg / (mm of Hg) <sup>8</sup>	Expansion Joint	Retaining Ring Set	Control Rod Assembly 9
<b>54</b>	(1350)	<b>16</b>	(406)	4.8 (120)	2.4 (60)	2.2 (56)	5.0	2	2599.53 (16770)	80 (5.5)	26 (660)	281.5 (127.7)	150.0 (162.7)	67.0 (30.4)
<b>60</b>	(1500)	<b>18</b>	(450)	4.8 (120)	2.4 (60)	2.2 (56)	4.5	2	3208.97 (20703)	80 (5.5)	26 (660)	358.7 (162.7)	200.0 (90.7)	72.0 (32.7)
<b>66</b>	(1650)	<b>18</b>	(450)	4.8 (120)	2.4 (60)	2.2 (56)	4.1	2	3839.51 (24771)	80 (5.5)	26 (660)	419.0 (190.1)	240.0 (108.8)	75.0 (34.0)
<b>72</b>	(1800)	<b>18</b>	(450)	4.8 (120)	2.4 (60)	2.2 (56)	3.8	2	4526.62 (29244)	70 (5.0)	26 (660)	478.8 (217.2)	290.0 (131.5)	94.0 (42.6)
<b>78</b>	(1950)	<b>18</b>	(450)	4.5 (112)	2.5 (64)	2.0 (51)	5.2	2	5410.60 (34907)	85 (6.0)	26 (660)	754.0 (342.0)	315.0 (142.9)	111.0 (50.3)
<b>84</b>	(2100)	<b>18</b>	(450)	4.5 (112)	2.5 (64)	2.0 (51)	4.6	2	6221.13 (40136)	85 (6.0)	26 (660)	819.0 (371.5)	350.0 (158.0)	121.0 (54.9)
<b>96</b>	(2400)	<b>18</b>	(450)	4.5 (112)	2.5 (64)	2.0 (51)	4.0	2	8011.85 (51689)	85 (6.0)	26 (660)	1300.0 (589.7)	367.0 (170.5)	134.0 (60.8)
<b>108</b>	(2700)	<b>18</b>	(450)	4.5 (112)	2.5 (64)	2.0 (51)	3.4	2	10029.75 (64702)	85 (6.0)	26 (660)	1462.0 (663.2)	425.0 (192.7)	153.0 (69.4)
<b>120</b>	(3000)	<b>18</b>	(450)	4.5 (112)	2.5 (64)	2.0 (51)	3.0	2	12271.84 (79173)	85 (6.0)	26 (660)	1820.0 (825.5)	565.0 (256.2)	167.0 (75.7)

**NOTES:**

1. Concurrent Movements - Concurrent movements are developed when two or more movements in a pipe system occur at the same time. If multiple movements exceed single arch design there may be a need for additional arches. To perform calculation for concurrent movement when a pipe system design has more than one movement, please use the following formula:  

$$\frac{\text{Actual Axial Compression} + \text{Actual Axial Extension} + \text{Actual Lateral (X)} + \text{Actual Lateral (Y)}}{\text{Rated Axial Compression} + \text{Rated Axial Extension} + \text{Rated Lateral (X)} + \text{Rated Lateral (Y)}} = / < 1$$
 Calculation must be equal to or less than 1 for expansion joint to operate within concurrent movement capability.
2. Filled Arch Rubber Expansion Joints - Known as Style FA 232. The Series FA230 rubber expansion joints should be selected when there are 20% or more solids being conveyed in the pipe system. The filled arch products are manufactured with seamless tube filled with a lower durometer rubber in the arch core. The filled arch product will have a 50% reduced movement capability from the information provided in Table 3.
3. Pressure rating is based on 170° F operating temperature with a 4:1 safety factor. At higher temperatures, the pressure rating is reduced slightly. Hydrostatic testing at 1.5 times rated maximum catalogue pressure or design working pressure of pipe system for 10 minutes is available upon request.
4. Weights are approximate and vary due to length.
5. The degree of angular movement is based on the maximum rated extension.
6. Torsional movement is expressed when the expansion joint is at neutral length.
7. Calculation of Thrust (Thrust Factor). When expansion joints are installed in the pipeline, the static portion of the thrust is calculated as a product of the area of the I.D. of the arch of the expansion joint times the maximum pressure (design, test or surge) that will occur in the line. The result is a force expressed in pounds. Take Design, surge or test pressure X thrust factor to calculate end thrust.
8. Parts listed at 26" Hg / 660 mm Hg vacuum have a design rating of 30" Hg / 762 mm Hg (full vacuum). Vacuum rating is based on neutral installed length, without external load. Products should not be installed "extended" on vacuum applications.
9. Limit rod unit weight consists of one rod with washers, nuts and two limit rod plates. Multiply number of limit rods needed for the application (as specified in the Fluid

**"Effective Area"**

Thrust Factor=

$$T = \frac{\pi}{4} (D)^2 \cdot (P)$$

T= Thrust  
 P= PSI (Design, Test or Surge)  
 D= Arch I.D.

# Style 233 Performance Data

**Table 4: Sizes • Movements • Design Pressures • Weights**

Expansion Joint Size Nom. I.D. Inch / (mm)		Neutral Length Inch / (mm)		233 Movement Capability: <sup>1,2</sup> From Neutral Position (Non-Concurrent)					Operating Conditions <sup>3</sup>			Weights lbs / (kgs) <sup>4</sup>		
				Axial Compression Inch / (mm)	Axial Extension Inch / (mm)	Lateral Deflection Inch / (mm)	Angular Deflection <sup>5</sup> (Degrees)	Torsional Rotation <sup>6</sup> (Degrees)	Thrust Factor <sup>7</sup> In <sup>2</sup> / (cm <sup>2</sup> )	Positive PSIG (Bar)	Vacuum Inches of Hg / (mm of Hg) <sup>8</sup>	Expansion Joint	Retaining Ring Set	Control Rod Assembly <sup>9</sup>
<b>1.5</b>	(40)	<b>14</b>	(356)	2.4 (60)	1.2 (30)	1.4 (36)	67.4	2	7.44 (48)	200 (14.0)	26 (660)	4.0 (1.8)	2.5 (1.1)	6.0 (2.7)
<b>2</b>	(50)	<b>14</b>	(356)	4.1 (105)	2.0 (52)	1.9 (48)	63.9	2	12.40 (80)	200 (14.0)	26 (660)	5.5 (2.5)	4.0 (1.8)	7.0 (3.2)
<b>2.5</b>	(65)	<b>14</b>	(356)	4.1 (105)	2.0 (52)	1.9 (48)	58.5	2	15.66 (101)	200 (14.0)	26 (660)	6.0 (2.7)	4.5 (2.0)	7.0 (3.2)
<b>3</b>	(80)	<b>14</b>	(356)	4.1 (105)	2.0 (52)	1.9 (48)	53.4	2	19.38 (125)	200 (14.0)	26 (660)	7.0 (3.2)	5.5 (4.3)	7.3 (3.4)
<b>4</b>	(100)	<b>14</b>	(356)	4.1 (105)	2.0 (52)	1.9 (48)	45.6	2	27.90 (180)	200 (14.0)	26 (660)	9.0 (4.1)	8.0 (3.6)	8.0 (3.6)
<b>5</b>	(125)	<b>14</b>	(356)	4.7 (120)	2.4 (60)	2.1 (54)	39.2	2	38.13 (246)	190 (13.0)	26 (660)	11.0 (5.0)	8.5 (3.9)	8.0 (3.6)
<b>6</b>	(150)	<b>14</b> <b>16</b>	(356) (406)	4.7 (120)	2.4 (60)	2.1 (54)	34.2	2	49.91 (322)	190 (13.0)	26 (660)	13.5 (6.1)	9.5 (4.3)	12.0 (5.4)
<b>8</b>	(200)	<b>14</b> <b>16</b>	(356) (406)	4.7 (120)	2.4 (60)	2.1 (54)	27.0	2	77.97 (503)	190 (13.0)	26 (660)	18.0 (8.2)	14.5 (6.6)	12.0 (5.4)
<b>10</b>	(250)	<b>18</b>	(457)	4.7 (120)	2.4 (60)	2.1 (54)	25.6	2	119.97 (774)	190 (13.0)	26 (660)	31.0 (14.1)	17.0 (7.7)	16.0 (7.2)
<b>12</b>	(300)	<b>18</b>	(457)	4.7 (120)	2.4 (60)	2.4 (60)	25.6	2	161.98 (1045)	190 (13.0)	26 (660)	40.0 (18.1)	24.5 (11.0)	16.0 (7.2)
<b>14</b>	(350)	<b>18</b> <b>20</b>	(457) (508)	4.7 (120)	2.4 (60)	2.4 (60)	18.9	2	210.18 (1356)	130 (9.0)	26 (660)	48.5 (22.0)	27.0 (12.3)	16.0 (7.2)
<b>16</b>	(400)	<b>18</b> <b>20</b>	(457) (508)	4.7 (120)	2.4 (60)	2.4 (60)	16.7	2	264.74 (1708)	115 (8.0)	26 (660)	55.0 (24.0)	33.5 (15.2)	20.0 (9.1)
<b>18</b>	(450)	<b>18</b> <b>20</b>	(457) (508)	4.7 (120)	2.4 (60)	2.4 (60)	14.9	2	325.50 (2100)	115 (8.0)	26 (660)	66.0 (27.7)	34.0 (15.5)	21.0 (9.5)
<b>20</b>	(500)	<b>18</b> <b>20</b>	(457) (508)	4.7 (120)	2.4 (60)	2.4 (60)	13.5	2	392.62 (2533)	115 (8.0)	26 (660)	78.0 (35.4)	38.0 (17.2)	21.0 (9.5)
<b>24</b>	(600)	<b>20</b>	(508)	6.0 (150)	3.0 (75)	2.7 (69)	14.0	2	562.03 (3626)	100 (7.0)	26 (660)	91.5 (41.5)	48.0 (21.8)	32.0 (14.5)
<b>30</b>	(750)	<b>20</b>	(508)	6.0 (150)	3.0 (75)	2.7 (69)	11.3	2	842.27 (5434)	90 (6.0)	26 (660)	131.0 (59.4)	63.0 (28.6)	32.0 (14.5)
<b>36</b>	(900)	<b>20</b>	(508)	6.0 (150)	3.0 (75)	2.7 (69)	9.5	2	1179.09 (7607)	90 (6.0)	26 (660)	157.0 (71.2)	76.0 (34.5)	43.0 (19.5)
<b>42</b>	(1050)	<b>22</b>	(559)	7.2 (180)	3.6 (90)	3.3 (84)	6.5	2	1628.28 (10505)	80 (5.5)	26 (660)	242.0 (109.8)	100.0 (45.4)	50.0 (22.7)
<b>48</b>	(1200)	<b>22</b>	(559)	7.2 (180)	3.6 (90)	3.3 (84)	5.7	2	2085.53 (13455)	80 (5.5)	26 (660)	257.0 (116.6)	132.0 (59.9)	52.0 (23.6)

Neutral lengths in RED are the recommended minimum lengths.

Metric Conversion Formula: Nominal I.D. : in. x 25 = mm; Neutral length: in. x 25.4 = mm



**Table 4: Sizes • Movements • Design Pressures • Weights**

Expansion Joint Size Nom. I.D. Inch / (mm)		Neutral Length Inch / (mm)		233 Movement Capability: <sup>1, 2</sup> From Neutral Position (Non-Concurrent)					Operating Conditions <sup>3</sup>			Weights lbs / (kgs) <sup>4</sup>		
				Axial Compression Inch / (mm)	Axial Extension Inch / (mm)	Lateral Deflection Inch / (mm)	Angular Deflection <sup>5</sup> (Degrees)	Torsional Rotation <sup>6</sup> (Degrees)	Thrust Factor <sup>7</sup> In <sup>2</sup> / (cm <sup>2</sup> )	Positive PSIG (Bar)	Vacuum Inches of Hg / (mm of Hg) <sup>8</sup>	Expansion Joint	Retaining Ring Set	Control Rod Assembly <sup>9</sup>
<b>54</b>	(1350)	<b>22</b>	(559)	7.2 (180)	3.6 (90)	3.3 (84)	5.0	2	2599.53 (16770)	80 (5.5)	26 (660)	325.0 (147.4)	150.0 (162.7)	70.0 (31.8)
<b>60</b>	(1500)	<b>24</b>	(610)	7.2 (180)	3.6 (90)	3.3 (84)	4.5	2	3208.97 (20703)	80 (5.5)	26 (660)	413.0 (187.3)	200.0 (90.7)	76.0 (34.5)
<b>66</b>	(1650)	<b>24</b>	(610)	7.2 (180)	3.6 (90)	3.3 (84)	4.1	2	3839.51 (24771)	80 (5.5)	26 (660)	482.0 (218.6)	240.0 (108.8)	79.0 (35.8)
<b>72</b>	(1800)	<b>24</b>	(610)	7.2 (180)	3.6 (90)	3.3 (84)	3.8	2	4526.62 (29244)	70 (5.0)	26 (660)	551.0 (249.9)	290.0 (131.5)	100.0 (45.4)
<b>78</b>	(1950)	<b>24</b>	(610)	6.75 (169)	3.75 (94)	3.0 (75)	5.2	2	5410.60 (34907)	85 (6.0)	26 (660)	868.0 (393.7)	315.0 (142.9)	118.0 (53.5)
<b>84</b>	(2100)	<b>24</b>	(610)	6.75 (169)	3.75 (94)	3.0 (75)	4.6	2	6221.13 (40136)	85 (6.0)	26 (660)	942.0 (427.3)	350.0 (158.0)	130.0 (59.0)
<b>96</b>	(2400)	<b>24</b>	(610)	6.75 (169)	3.75 (94)	3.0 (75)	4.0	2	8011.85 (51689)	85 (6.0)	26 (660)	1495.0 (678.1)	367.0 (170.5)	144.0 (65.3)
<b>108</b>	(2700)	<b>24</b>	(610)	6.75 (169)	3.75 (94)	3.0 (75)	3.4	2	10029.75 (64702)	85 (6.0)	26 (660)	1682.0 (762.9)	425.0 (192.7)	169.0 (76.7)
<b>120</b>	(3000)	<b>24</b>	(610)	6.75 (169)	3.75 (94)	3.0 (75)	3.0	2	12271.84 (79173)	85 (6.0)	26 (660)	2093.0 (949.4)	565.0 (256.2)	183.0 (83.0)

**NOTES:**

- Concurrent Movements - Concurrent movements are developed when two or more movements in a pipe system occur at the same time. If multiple movements exceed single arch design there may be a need for additional arches. To perform calculation for concurrent movement when a pipe system design has more than one movement, please use the following formula:  

$$\frac{\text{Actual Axial Compression} + \text{Actual Axial Extension} + \text{Actual Lateral (X)} + \text{Actual Lateral (Y)}}{\text{Rated Axial Compression} + \text{Rated Axial Extension} + \text{Rated Lateral (X)} + \text{Rated Lateral (Y)}} = / < 1$$
 Calculation must be equal to or less than 1 for expansion joint to operate within concurrent movement capability.
- Filled Arch Rubber Expansion Joints - Known as Style FA 233. The Series FA230 rubber expansion joints should be selected when there are 20% or more solids being conveyed in the pipe system. The filled arch products are manufactured with seamless tube filled with a lower durometer rubber in the arch core. The filled arch product will have a 50% reduced movement capability from the information provided in Table 4.
- Pressure rating is based on 170° F operating temperature with a 4:1 safety factor. At higher temperatures, the pressure rating is reduced slightly. Hydrostatic testing at 1.5 times rated maximum catalogue pressure or design working pressure of pipe system for 10 minutes is available upon request.
- Weights are approximate and vary due to length.
- The degree of angular movement is based on the maximum rated extension.
- Torsional movement is expressed when the expansion joint is at neutral length.
- Calculation of Thrust (Thrust Factor). When expansion joints are installed in the pipeline, the static portion of the thrust is calculated as a product of the area of the I.D. of the arch of the expansion joint times the maximum pressure (design, test or surge) that will occur in the line. The result is a force expressed in pounds. **Take Design, surge or test pressure X thrust factor to calculate end thrust.**
- Parts listed at 26" Hg / 660 mm Hg vacuum have a design rating of 30" Hg / 762 mm Hg (full vacuum). Vacuum rating is based on neutral installed length, without external load. Products should not be installed "extended" on vacuum applications.
- Limit rod unit weight consists of one rod with washers, nuts and two limit rod plates. Multiply number of limit rods needed for the application (as specified in the Fluid

**"Effective Area"**

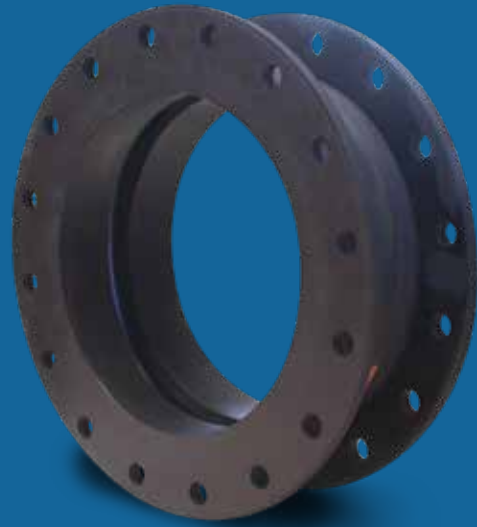
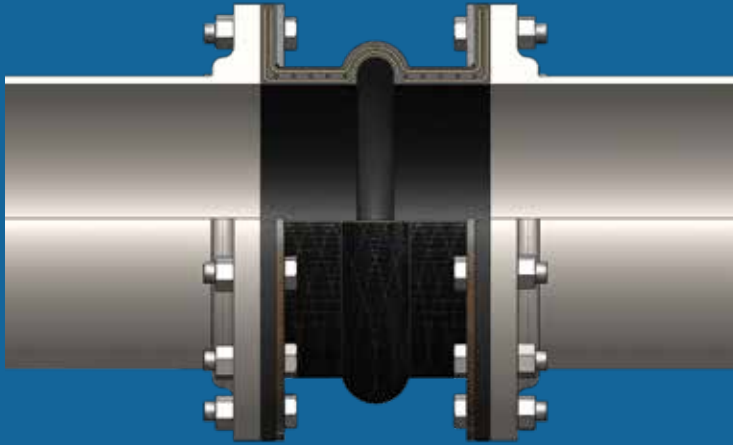
**Thrust Factor=**

$$T = \frac{\pi}{4} (D)^2 (P)$$

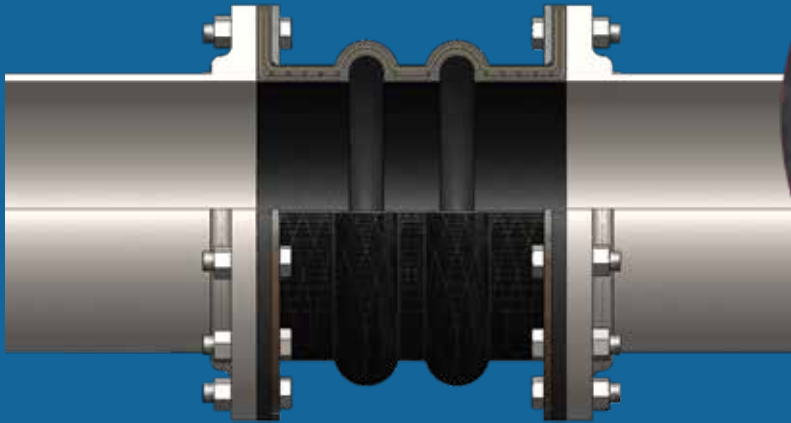
T= Thrust  
P= PSI (Design, Test or Surge)  
D= Arch I.D.

# Series 230

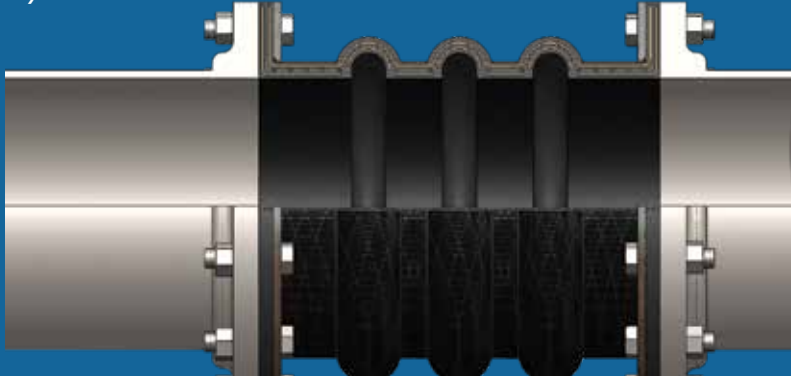
Style 231



Style 232

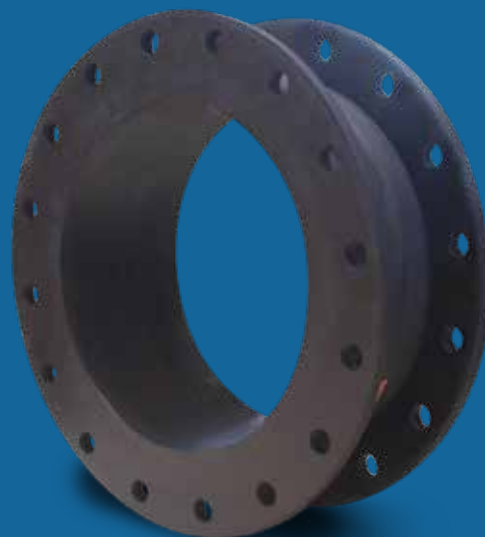
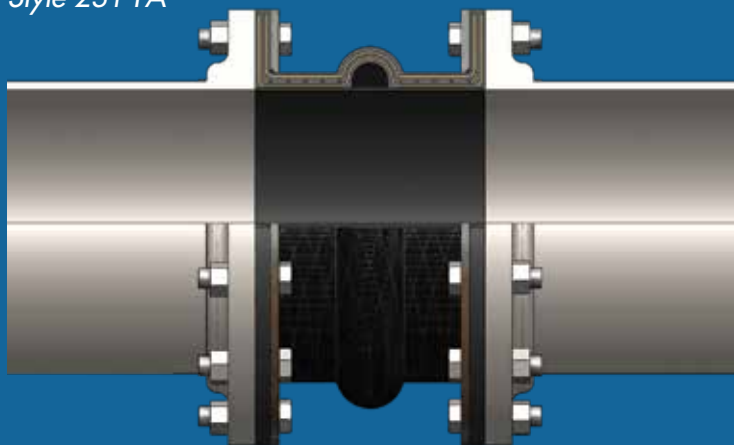


Style 233

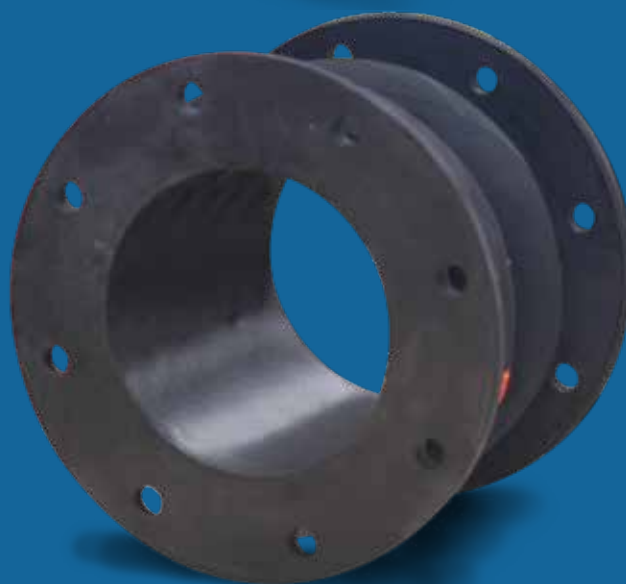
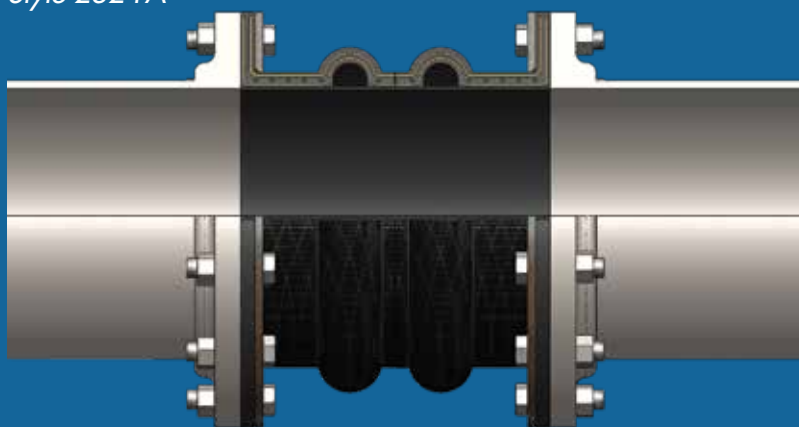


# Series 230 FA

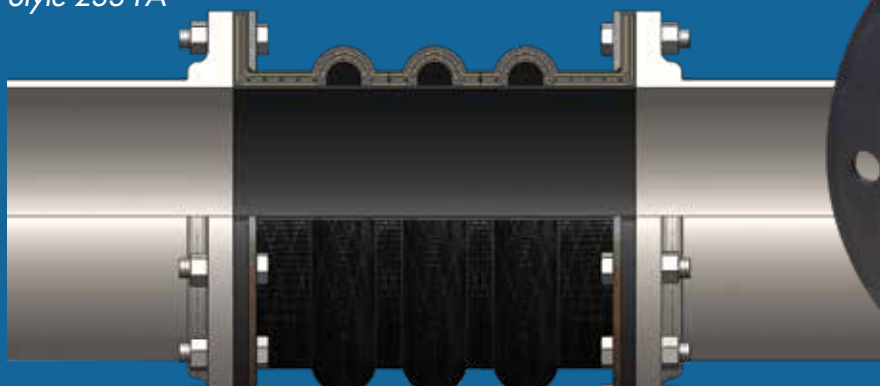
Style 231 FA



Style 232 FA



Style 233 FA



# Style 230 Drilling Chart

Table 5		Standard Drilling for PROCO Rubber Expansion Joints				Thickness of Materials for PROCO Rubber Expansion Joints				Control Unit Plate Detail								
Nominal Pipe Size Expansion Joint I.D. Inch / (mm)		Flange Dimensions <sup>2</sup>				Material Thickness <sup>1</sup> for Bolt Length Requirements				Control Unit Plate Detail								
		Flange O.D. Inch / (mm)		Bolt Circle Inch / (mm)		Number Of Holes		Size Of Holes Inch / (mm)						Retaining Rings Thickness Inch / (mm)		Rubber Flange Thickness Inch / (mm)		Adjacent <sup>3</sup> Mating Flange Thickness
												Max. Control <sup>4</sup> Rod Plate Thickness Inch / (mm)		Control Rod <sup>6</sup> Plate O.D. Inch / (mm)		Maximum <sup>7</sup> Rod Diameter Inch / (mm)		
1	(25)	4.25	(107.95)	3.13	(79.50)	4	0.625	(15.9)	0.375	(9.53)	0.472	(11.99)	0.625	(15.9)	8.375	(212.7)	0.625	(15.9)
1.25	(32)	4.63	(117.60)	3.50	(88.90)	4	0.625	(15.9)	0.375	(9.53)	0.472	(11.99)	0.625	(15.9)	8.750	(222.3)	0.625	(15.9)
1.5	(40)	5.00	(127.00)	3.88	(98.55)	4	0.625	(15.9)	0.375	(9.53)	0.472	(11.99)	0.375	(9.5)	9.125	(231.8)	0.625	(15.9)
2	(50)	6.00	(152.40)	4.75	(120.65)	4	0.750	(19.1)	0.375	(9.53)	0.472	(11.99)	0.500	(12.7)	10.125	(257.2)	0.625	(15.9)
2.5	(65)	7.00	(177.80)	5.50	(139.70)	4	0.750	(19.1)	0.375	(9.53)	0.472	(11.99)	0.500	(12.7)	11.125	(282.6)	1.000	(25.4)
3	(80)	7.50	(190.50)	6.00	(152.40)	4	0.750	(19.1)	0.375	(9.53)	0.472	(11.99)	0.500	(12.7)	11.625	(295.3)	1.000	(25.4)
3.5	(90)	8.50	(215.90)	7.00	(177.80)	8	0.750	(19.1)	0.375	(9.53)	0.472	(11.99)	0.625	(15.9)	12.625	(320.7)	1.000	(25.4)
4	(100)	9.00	(228.60)	7.50	(190.50)	8	0.750	(19.1)	0.375	(9.53)	0.472	(11.99)	0.625	(15.9)	13.125	(333.4)	1.000	(25.4)
5	(125)	10.00	(254.00)	8.50	(215.90)	8	0.875	(22.2)	0.375	(9.53)	0.551	(14.00)	0.625	(15.9)	14.125	(358.8)	1.000	(25.4)
6	(150)	11.00	(279.40)	9.50	(241.30)	8	0.875	(22.2)	0.375	(9.53)	0.551	(14.00)	0.500	(12.7)	15.125	(384.2)	1.000	(25.4)
8	(200)	13.50	(342.90)	11.75	(298.45)	8	0.875	(22.2)	0.375	(9.53)	0.630	(16.00)	0.750	(19.1)	19.125	(485.8)	1.000	(25.4)
10	(250)	16.00	(406.40)	14.25	(361.95)	12	1.000	(25.4)	0.375	(9.53)	0.630	(16.00)	0.750	(19.1)	21.625	(549.3)	1.000	(25.4)
12	(300)	19.00	(482.60)	17.00	(431.80)	12	1.000	(25.4)	0.375	(9.53)	0.748	(19.00)	0.750	(19.1)	24.625	(625.5)	1.000	(25.4)
14	(350)	21.00	(533.40)	18.75	(476.25)	12	1.125	(28.6)	0.375	(9.53)	0.866	(22.00)	0.750	(19.1)	26.625	(676.3)	1.000	(25.4)
16	(400)	23.50	(596.90)	21.25	(539.75)	16	1.125	(28.6)	0.375	(9.53)	0.866	(22.00)	0.750	(19.1)	30.125	(765.2)	1.250	(31.8)
18	(450)	25.00	(635.00)	22.75	(577.85)	16	1.250	(31.8)	0.375	(9.53)	0.866	(22.00)	0.750	(19.1)	31.625	(803.3)	1.250	(31.8)
20	(500)	27.50	(698.50)	25.00	(635.00)	20	1.250	(31.8)	0.375	(9.53)	0.984	(24.99)	0.750	(19.1)	34.125	(866.8)	1.250	(31.8)
22	(550)	29.50	(749.30)	27.25	(692.15)	20	1.375	(34.9)	0.375	(9.53)	0.984	(24.99)	1.000	(25.4)	36.125	(917.6)	1.250	(31.8)
24	(600)	32.00	(812.80)	29.50	(749.30)	20	1.375	(34.9)	0.375	(9.53)	0.984	(24.99)	1.000	(25.4)	38.625	(981.1)	1.250	(31.8)
26	(650)	34.25	(869.95)	31.75	(806.32)	24	1.375	(34.9)	0.375	(9.53)	0.984	(24.99)	1.000	(25.4)	40.875	(1038.2)	1.250	(31.8)
28	(700)	36.50	(927.10)	34.00	(863.60)	28	1.375	(34.9)	0.375	(9.53)	0.984	(24.99)	1.250	(31.8)	44.125	(1120.8)	1.500	(38.1)
30	(750)	38.75	(984.25)	36.00	(914.40)	28	1.375	(34.9)	0.375	(9.53)	0.984	(24.99)	1.250	(31.8)	46.375	(1177.9)	1.500	(38.1)
32	(800)	41.75	(1060.45)	38.50	(977.90)	28	1.625	(41.3)	0.375	(9.53)	0.984	(24.99)	1.250	(31.8)	49.375	(1254.1)	1.500	(38.1)
34	(850)	43.75	(1111.25)	40.50	(1028.70)	32	1.625	(41.3)	0.375	(9.53)	0.984	(24.99)	1.500	(38.1)	52.375	(1330.3)	1.750	(44.5)
36	(900)	46.00	(1168.40)	42.75	(1085.85)	32	1.625	(41.3)	0.375	(9.53)	0.984	(24.99)	1.500	(38.1)	54.625	(1387.5)	1.750	(44.5)
38	(950)	48.75	(1238.25)	45.25	(1149.35)	32	1.625	(41.3)	0.375	(9.53)	0.984	(24.99)	1.500	(38.1)	57.375	(1457.3)	1.750	(44.5)
40	(1000)	50.75	(1289.05)	47.25	(1200.15)	36	1.625	(41.3)	0.375	(9.53)	0.984	(24.99)	1.500	(38.1)	58.375	(1482.7)	1.750	(44.5)
42	(1050)	53.00	(1346.20)	49.50	(1257.30)	36	1.625	(41.3)	0.375	(9.53)	1.181	(30.00)	1.500	(38.1)	61.625	(1565.3)	1.750	(44.5)
44	(1100)	55.25	(1403.35)	51.75	(1314.45)	40	1.625	(41.3)	0.375	(9.53)	1.181	(30.00)	1.500	(38.1)	63.875	(1622.4)	1.750	(44.5)
46	(1150)	57.25	(1454.15)	53.75	(1365.25)	40	1.625	(41.3)	0.375	(9.53)	1.181	(30.00)	1.500	(38.1)	65.875	(1673.2)	1.750	(44.5)
48	(1200)	59.50	(1511.30)	56.00	(1422.40)	44	1.625	(41.3)	0.375	(9.53)	1.181	(30.00)	1.500	(38.1)	68.125	(1730.4)	1.750	(44.5)
50	(1250)	61.75	(1568.45)	58.25	(1479.55)	44	1.875	(47.6)	0.375	(9.53)	1.181	(30.00)	1.500	(38.1)	70.375	(1787.5)	1.750	(44.5)
52	(1300)	64.00	(1625.60)	60.50	(1536.70)	44	1.875	(47.6)	0.375	(9.53)	1.181	(30.00)	1.750	(44.5)	73.625	(1870.7)	2.000	(50.8)
54	(1350)	66.25	(1682.75)	62.75	(1593.85)	44	2.000	(50.8)	0.375	(9.53)	1.181	(30.00)	2.000	(50.8)	75.875	(1927.2)	2.000	(50.8)
56	(1400)	68.75	(1746.25)	65.00	(1651.00)	48	1.875	(47.6)	0.375	(9.53)	1.181	(30.00)	2.000	(50.8)	78.375	(1990.7)	2.000	(50.8)
58	(1450)	71.00	(1803.40)	67.25	(1708.15)	48	1.875	(47.6)	0.375	(9.53)	1.181	(30.00)	2.000	(50.8)	80.625	(2047.9)	2.000	(50.8)
60	(1500)	73.00	(1854.20)	69.25	(1758.95)	52	2.000	(50.8)	0.375	(9.53)	1.181	(30.00)	2.000	(50.8)	82.625	(2098.7)	2.000	(50.8)
66	(1650)	80.00	(2032.00)	76.00	(1930.40)	52	2.000	(50.8)	0.375	(9.53)	1.181	(30.00)	2.000	(50.8)	89.625	(2276.5)	2.000	(50.8)
68	(1700)	82.25	(2089.15)	78.25	(1987.55)	56	2.000	(50.8)	0.375	(9.53)	1.181	(30.00)	2.000	(50.8)	91.875	(2333.6)	2.000	(50.8)
72	(1800)	86.50	(2197.10)	82.50	(2095.50)	60	2.000	(50.8)	0.375	(9.53)	1.181	(30.00)	2.000	(50.8)	96.125	(2441.6)	2.000	(50.8)
78	(1950)	93.00	(2362.20)	89.00	(2260.60)	64	2.125	(53.0)	0.375	(9.53)	1.181	(30.00)	2.000	(50.8)	103.125	(2619.4)	2.250	(57.2)
84	(2100)	99.75	(2533.65)	95.50	(2425.70)	64	2.250	(57.2)	0.375	(9.53)	1.181	(30.00)	2.000	(50.8)	109.875	(2790.8)	2.250	(57.2)
90	(2250)	106.50	(2705.10)	102.00	(2590.80)	68	2.375	(60.3)	0.375	(9.53)	1.181	(30.00)	2.000	(50.8)	117.125	(2975.0)	2.500	(63.5)
96	(2400)	113.25	(2876.55)	108.50	(2755.90)	68	2.500	(63.5)	0.375	(9.53)	1.181	(30.00)	2.000	(50.8)	124.625	(3165.9)	2.750	(69.9)

CUSTOMER SPECIFY MATING FLANGE THICKNESS

Table 5		Standard Drilling for PROCO Rubber Expansion Joints						Thickness of Materials for PROCO Rubber Expansion Joints				Control Unit Plate Detail						
		Flange Dimensions <sup>2</sup>				Material Thickness <sup>1</sup> for Bolt Length Requirements												
Nominal Pipe Size Expansion Joint I.D. Inch / (mm)		Flange O.D. Inch / (mm)		Bolt Circle Inch / (mm)		Number Of Holes	Size Of Holes Inch / (mm)		Retaining Rings Thickness Inch / (mm)	Rubber Flange Thickness Inch / (mm)	Adjacent <sup>3</sup> Mating Flange Thickness	Max. Control <sup>4</sup> Rod Plate Thickness Inch / (mm)	Control Rod <sup>6</sup> Plate O.D. Inch / (mm)	Maximum <sup>7</sup> Rod Diameter Inch / (mm)				
		102	(2550)	120.00	(3048.00)		114.50	(2908.30)	72	2.625	(66.7)	0.375	(9.53)	1.181	(30.00)	2.000	(50.8)	131.375
108	(2700)	126.75	(3219.45)	120.75	(3067.05)	72	2.625	(66.7)	0.375	(9.53)	1.181	(30.00)	2.000	(50.8)	138.125	(3508.4)	2.750	(69.9)
120	(3000)	140.25	(3562.35)	132.75	(3371.85)	76	2.875	(73.0)	0.375	(9.53)	1.181	(30.00)	2.000	(50.8)	152.125	(3864.0)	3.000	(76.2)

Metric Conversion Formula: Nominal I.D. : in. x 25 = mm; Neutral length: in. x 25.4 = mm

**Notes:**

1. Limit/Control Rod length is determined by neutral length of rubber expansion joint, rated extension, control rod plate thickness, mating flange thickness and number of nuts. Consult PROCO for rod lengths.
2. Flange Dimensions shown are in accordance with ANSI B16.1 and ANSI B16.5 Class 125/150, AWWA C-207-07, Tbl 2 and 3 - Class D, Table 4 - Class E. Hole size shown is 1/8" larger than AWWA Standard.
3. Adjacent mating flange thickness is required to determine overall rod length and compression sleeve length (if required).
4. Plate thickness is based on a maximum width PROCO would use to design a Limit/Control Rod plate.
5. Flat Washers required at ring splits and are by others.
6. Control rod plate O.D. installed dimension is based on a maximum O.D. Proco would supply.
7. Control rod diameter is based on a maximum diameter Proco would use to design a control rod.
8. Additional flange drilling such as 300 LB., PN10, PN16 and other special drilling's are available upon request.

- A - Retaining Ring Thickness.
- B - Rubber Flange Thickness.
- C - Adjacent Mating Flange Thickness (By Others).
- D - Control Unit Plate Thickness.
- E - Double Nut Thickness is determined by Control Rod Diameter.
- F - Control Rod Bolt Length is determined by A through E + OAL <sup>1</sup>.
- G - Control Rod Control Rod Plate O.D.
- H - Maximum Rod Diameter

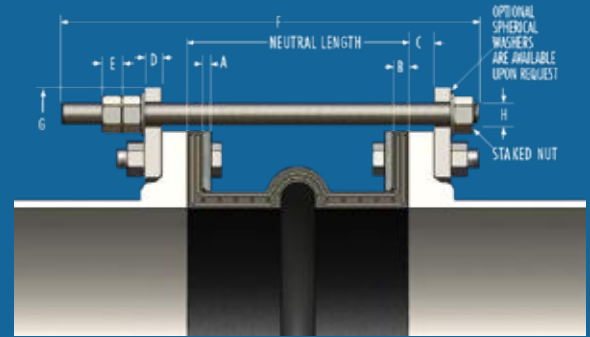
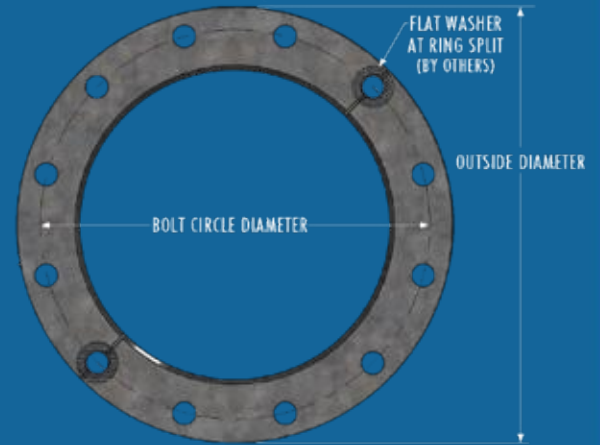


Figure 1

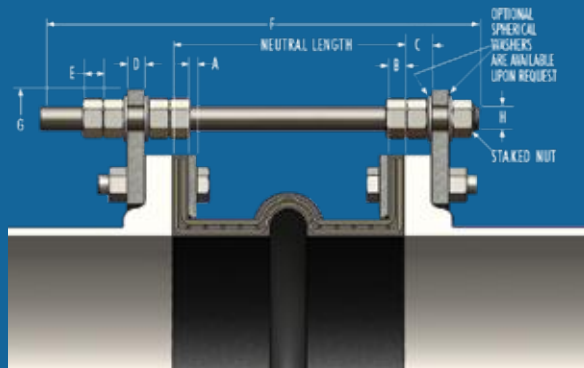
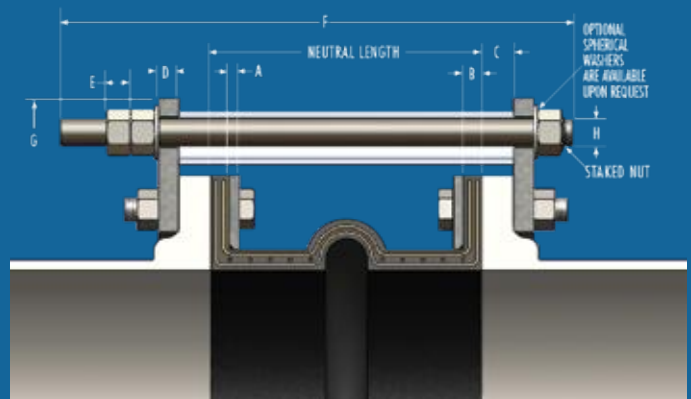


Figure 2



# Limit Rods, Control Rods & Compression Sleeves

## Use of Control Units with Rubber Expansion Joints

### Definition

A control unit assembly is a system of two or more control rod units (limit rods, tie rods or compression sleeves) placed across an expansion joint from flange to flange to minimize possible damage caused by excessive motion of a pipeline. The control unit assemblies can be set at the maximum allowable expansion and/or contraction of the rubber expansion joint. When used in this manner, control units are an additional safety factor and can minimize possible damage to adjacent equipment.

Rubber expansion joints should be installed between two fixed anchor points in a piping system. The pipe system must be rigidly anchored on both sides of the expansion joint to control expansion or contraction of the line. Piping anchors must be capable of withstanding the line thrusts generated by internal pressure or wide temperature fluctuations.

When proper anchoring cannot be provided, **CONTROL UNITS ARE REQUIRED.** For un-anchored piping systems nuts shall be tightened snug against rod plate to prevent over extension due to pressure thrust created by expansion joint. Refer to "Thrust Factor in Table 2, note 5 in this manual.

Listed below are three (3) control unit configurations supplied by PROCO and are commonly used with rubber expansion joints in piping systems.

### Figure 1

Known as a **LIMIT ROD**, this control unit configuration will allow an expansion joint to extend to a predetermined extension setting. Nuts shall be field set to no more than the maximum allowable extension movement of a rubber expansion joint (unless used in an un-anchored system). Refer to Table 2 in this manual for allowable movement capabilities. Spherical washers can also be furnished (upon request) to combat any "nut to plate" binding during offset. **Consult the systems engineer for proper nut settings prior to system operation.**

### Figure 2

Known as a **LIMIT/CONTROL ROD**, this control unit configuration is used to allow specified pipe expansion (expansion joint axial compression) and pipe contraction (expansion joint axial extension) movements. Nuts shall be field set to no more than the maximum allowable extension (unless used in an un-anchored pipe system) or compression of a rubber expansion joint. Refer to Table 2 in this manual for allowable movement capabilities. Internal and external nuts can also be field set to allow for no movement in the horizontal plane. This setting will allow the rubber to move laterally while keeping expansion joint thrust forces low on adjacent equipment. Spherical washers can also be furnished (upon request) to combat any potential "nut to plate" binding during offset. **Limit/Control rods with internal nuts must be specified at the time of inquiry. Consult the systems engineer for proper nut settings prior to system operation.**

### Figure 3

Known as a **COMPRESSION SLEEVE**, this configuration is used to allow for specified pipe expansion (expansion joint axial compression) and pipe contraction (expansion joint extension) movements. Nuts shall be field set to no more than the maximum allowable extension (unless used in an un-anchored pipe system) of a rubber expansion joint. Refer to Table 2 in this manual for allowable movement capabilities. PROCO will supply each compression sleeve to allow for no axial movement unless otherwise specified by the purchaser. Compression sleeves shall be field trimmed to meet required allowable axial movement as set forth by system requirements. Spherical washers can also be furnished (upon request) to combat any potential "nut to plate" binding during offset. **Consult the systems engineer for proper sleeve lengths prior to system operation.**

### Important Control Unit Considerations

The number of rods, control rod diameters and control rod plate thicknesses are important considerations when specifying control units for an application. As a minimum, specifying engineers or purchasers shall follow the guidelines as set forth in Appendix C of the Fluid Sealing Association's Technical Handbook, Seventh Edition. PROCO engineers its control unit assemblies to system requirements. Our designs incorporate an allowable stress of 65% of material yield for each rod and plate (rod and plate material to be specified by purchaser). Therefore, it is important to provide pressure and temperature ratings to PROCO when requesting control units for rubber expansion joints. It is also important to provide adjacent

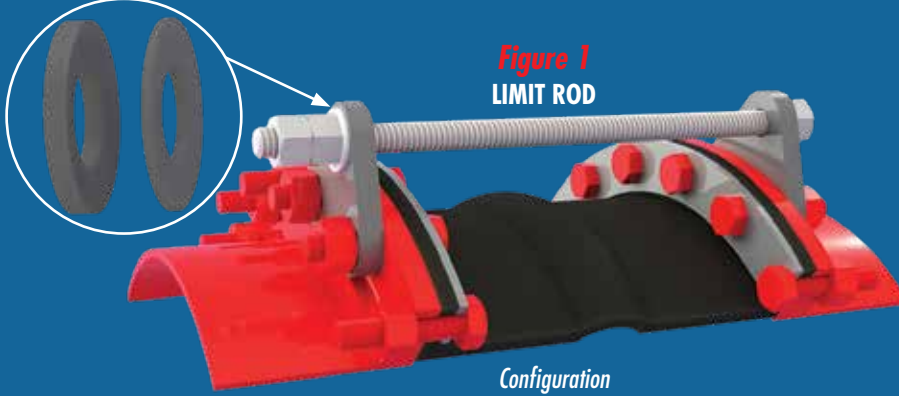
### Installation Instructions for Control Rods

1. Assemble expansion joint between pipe flanges in its manufactured face-to-face length. Install the retaining rings furnished with the expansion joint.
2. Assemble control rod plates behind pipe flanges as shown. Flange bolts or all thread studs through the control rod plate must be longer to accommodate the plate thickness. Control rod plates should be equally spaced around the flange. Depending upon the size and pressure rating of the system, 2, 3, 4, or more control/limit rods may be required. Refer to Table 4 in this manual or to the Fluid Sealing Association's Technical Handbook, Seventh Edition, page 23 for control rod pressure ratings.
3. Insert control/limit rods through top plate holes. Steel flat washers are to be positioned at outer plate surface.
4. If a single nut per unit is furnished, position this nut so that there is a gap between the nut and the steel flat washer. This gap is equal to the joints maximum extension (commencing with the nominal face-to-face length). To lock this nut in position, either "stake" the thread in two places or tack weld the nut to the rod. If two nuts are supplied, the nuts will create a "jamming" effect to prevent loosening. (Nuts should be snug against flat washer and control rod plate when piping system is un-anchored.)

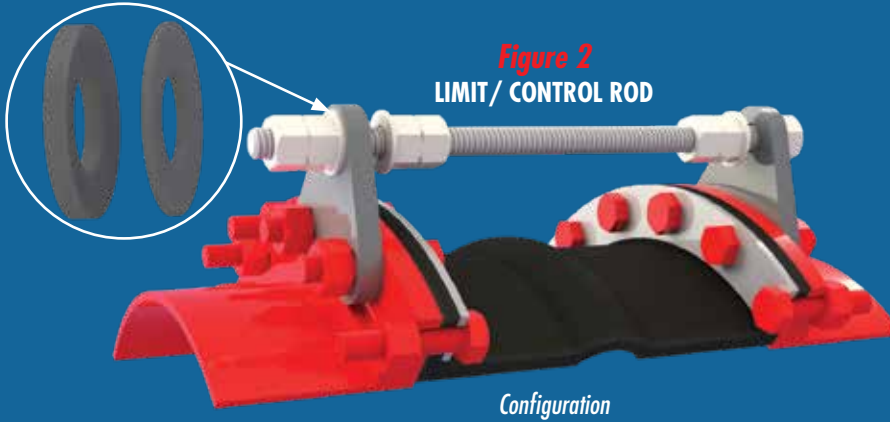
*Note: Consult the manufacturer if there are any questions as to the rated compression and elongation. These two dimensions are critical in setting the nuts and sizing the compression pipe sleeve (if supplied).*

5. If there is a requirement for compression pipe sleeves, ordinary pipe may be used, sized in length to allow the joint to be compressed to its normal limit.
6. If there is a requirement for optional spherical washers, these washers are to be positioned at outer plate surface and backed

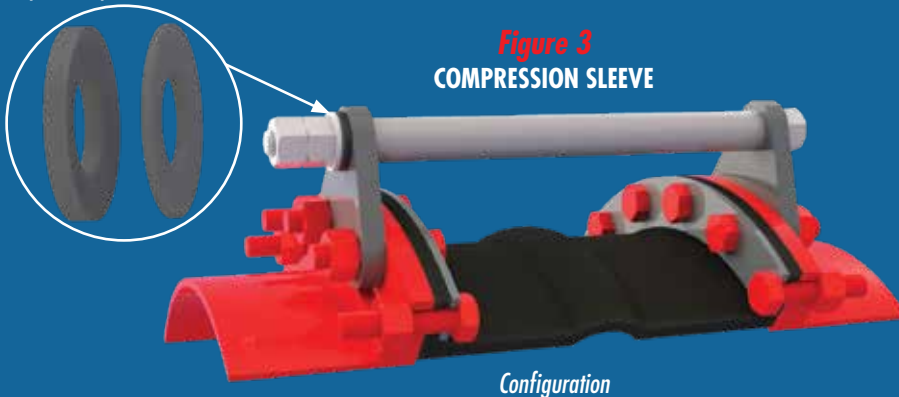
Optional Spherical Washers



Optional Spherical Washers



Optional Spherical Washers



<b>Table 6</b>		<b>Maximum Surge or Test Pressure of the Systems</b>			
<b>Nominal Pipe Size Expansion Joint I.D. Inch / (mm)</b>		<b>Number of Control Rods Recommended</b>			
		<b>2</b>	<b>4</b>	<b>6</b>	<b>8</b>
<b>2</b>	(51)	661	•	•	•
<b>4</b>	(102)	311	622	•	•
<b>6</b>	(152)	186	371	•	•
<b>8</b>	(203)	163	326	•	•
<b>10</b>	(254)	163	325	488	•
<b>12</b>	(305)	160	320	481	•
<b>14</b>	(356)	112	223	335	•
<b>16</b>	(406)	113	227	340	453
<b>18</b>	(457)	94	187	281	375
<b>20</b>	(508)	79	158	236	315
<b>22</b>	(559)	85	171	256	342
<b>24</b>	(610)	74	147	221	294
<b>26</b>	(660)	62	124	186	248
<b>28</b>	(711)	65	130	195	261
<b>30</b>	(762)	70	141	211	281
<b>32</b>	(813)	63	125	188	251
<b>34</b>	(864)	72	143	215	286
<b>36</b>	(914)	69	138	207	276
<b>38</b>	(965)	63	125	188	251
<b>40</b>	(1016)	42	85	127	169
<b>42</b>	(1067)	48	96	144	192
<b>44</b>	(1118)	44	88	133	177
<b>46</b>	(1168)	41	82	122	163
<b>48</b>	(1219)	40	81	141	161
<b>50</b>	(1270)	37	75	112	150
<b>52</b>	(1321)	35	70	105	140
<b>54</b>	(1372)	43	86	128	171
<b>56</b>	(1422)	40	80	120	160
<b>58</b>	(1473)	38	75	113	150
<b>60</b>	(1524)	35	71	106	141
<b>62</b>	(1575)	33	66	100	133
<b>66</b>	(1676)	30	59	89	119
<b>72</b>	(1829)	25	50	75	101
<b>78</b>	(1981)	28	56	84	112
<b>84</b>	(2134)	24	49	73	98
<b>90</b>	(2286)	26	53	79	106
<b>98</b>	(2489)	29	58	86	115
<b>102</b>	(2591)	25	51	76	102
<b>108</b>	(2743)	23	46	75	92
<b>120</b>	(3048)	18	37	56	75

Notes:  
 1. Pressures listed above do not relate to the actual design pressure of the expansion joint products, but are the maximum surge or pressure for a specific control rod nominal pipe size.

# Installation Instructions for Non-Metallic Expansion Joints

## 1. Service Conditions:

Make sure the expansion joint rating for temperature, pressure, vacuum and movements match the system requirements. Contact the manufacturer for advice if the system requirements exceed those of the expansion joint selected. Check to make sure the elastomer selected is chemically compatible with the process fluid or gas.

## 2. Alignment:

Expansion joints are normally not designed to make up for piping misalignment errors. Piping should be lined up within 1/8". Misalignment reduces the rated movements of the expansion joint and can induce severe stress and reduce service life. Pipe guides should be installed to keep the pipe aligned and to prevent undue displacement.

## 3. Anchoring:

Solid anchoring is required wherever the pipeline changes direction and expansion joints should be located as close as possible to anchor points. If piping is not adequately anchored, control rods should be used. If anchors are not used, pressure thrust may cause excessive movement damaging the expansion joint.

## 4. Pipe Support:

Piping must be supported by hangers or anchors so expansion joints do not carry any pipe weight.

## 5. Mating Flanges:

Install the expansion joint against the mating pipe flanges and install bolts so that the bolt head and washer are against the retaining rings. If washers are not used, flange leakage can result – particularly at the split in the retaining rings. Flange-to-flange dimension of the expansion joint must match the breech opening. Make sure the mating flanges are clean and are flat faced type or no more than 1/16" raised face type. Never install expansion joints that utilize split retaining rings next to wafer type check or butterfly valves. Serious damage can result to a rubber joint of this type unless installed against full face flanges.

## 6. Bolting Torque:

Table 7 shows the recommended torque ranges for non-metallic expansion joints with full-faced rubber flanges: Torque specifications are approximate. Tighten bolts in stages using cross-bolt tightening pattern. If the joint has integral fabric and rubber flanges, the bolts should be tight enough to make the rubber flange OD bulge between the retaining rings and the mating flange. After installation, the system should be pressurized and examined to confirm a proper seal. Torque bolts sufficiently to assure leak free operation at hydrostatic test pressure. *Note: Torque values are approximate due to mating flange surfaces, installation offsets, operating pressures and environmental conditions.*

## 7. Storage:

Ideal storage is in a warehouse with a relatively dry, cool location. Store flanges face down on a pallet or wooden platform. Do not store other heavy items on top of expansion joints. Ten year shelf life can be expected with ideal conditions. If storage must be outdoors, place on wooden platform and joints should not be in contact with the ground. Cover with a tarpaulin.

## 8. Large Joint Handling:

Do not lift with ropes or bars through the bolt holes. If lifting through the bore, use padding or a saddle to distribute the weight. Make sure cables or forklift tines do not contact the rubber. Do not let expansion joints sit vertically on the edges of the flanges for any period of time.

## 9. Additional Tips:

- A. Do not insulate over a non-metallic expansion joint; however, if insulation is required, it should be made removable to permit easy access to the flanges. This facilitates periodic inspection of the tightness of the joint bolting.
- B. It is acceptable (but not necessary) to lubricate the expansion joint flanges with a thin film of graphite dispersed in glycerin or water to ease disassembly at a later time.
- C. Do not weld in the near vicinity of a non-metallic joint.
- D. If expansion joints are to be installed underground, or will be submerged in water, contact manufacturer for specific recommendations.
- E. If the expansion joint will be installed outdoors, make sure the cover material will withstand ozone, sunlight, etc.
- F. Check the tightness of lead-free flanges two or three weeks after installation and retighten if necessary.

Table 7	Approximate
Size	Torque Values
1" THRU 2"	20 - 40 ft/lbs
2.5" THRU 5"	25 - 60 ft/lbs
6" THRU 12"	35 - 140 ft/lbs
14" THRU 18"	50 - 180 ft/lbs
20" THRU 24"	60 - 200 ft/lbs
26" THRU 40"	70 - 300 ft/lbs
42" THRU 50"	80 - 300 ft/lbs
52" THRU 60"	100 - 400 ft/lbs
66" THRU 72"	200 - 500 ft/lbs
78" THRU 90"	300 - 600 ft/lbs
96" THRU 108"	400 - 700 ft/lbs
120"	500 - 800 ft/lbs

*Warning: Expansion joints may operate in pipelines or equipment carrying fluids and/or gasses at elevated temperature and pressures and may transport hazardous materials. Precautions should be taken to protect personnel in the event of leakage or splash. Rubber joints should not be installed in areas where inspection is*

# Piping System Layout Examples

## Anchored System

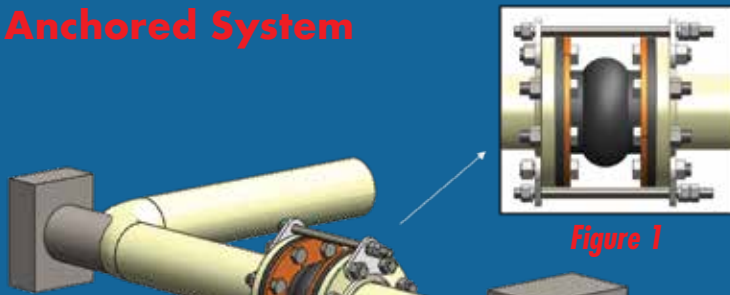


Figure 1



Figure 2

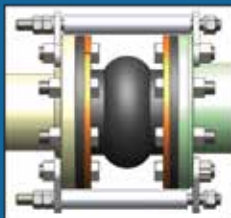


Figure 3

### Anchored System Note:

Although limit rods, control rods or limit rods with compression sleeves are not required in an anchored pipe system, you may want to consider using them. If an anchor were to fail, any rod configuration would be capable of handling the pressure thrust of the system and lessen the likelihood of an expansion joint failure.

## Un-Anchored System

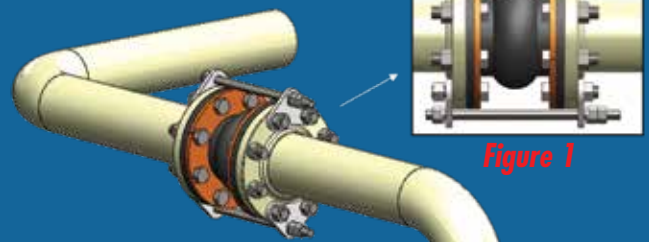


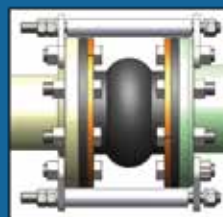
Figure 1

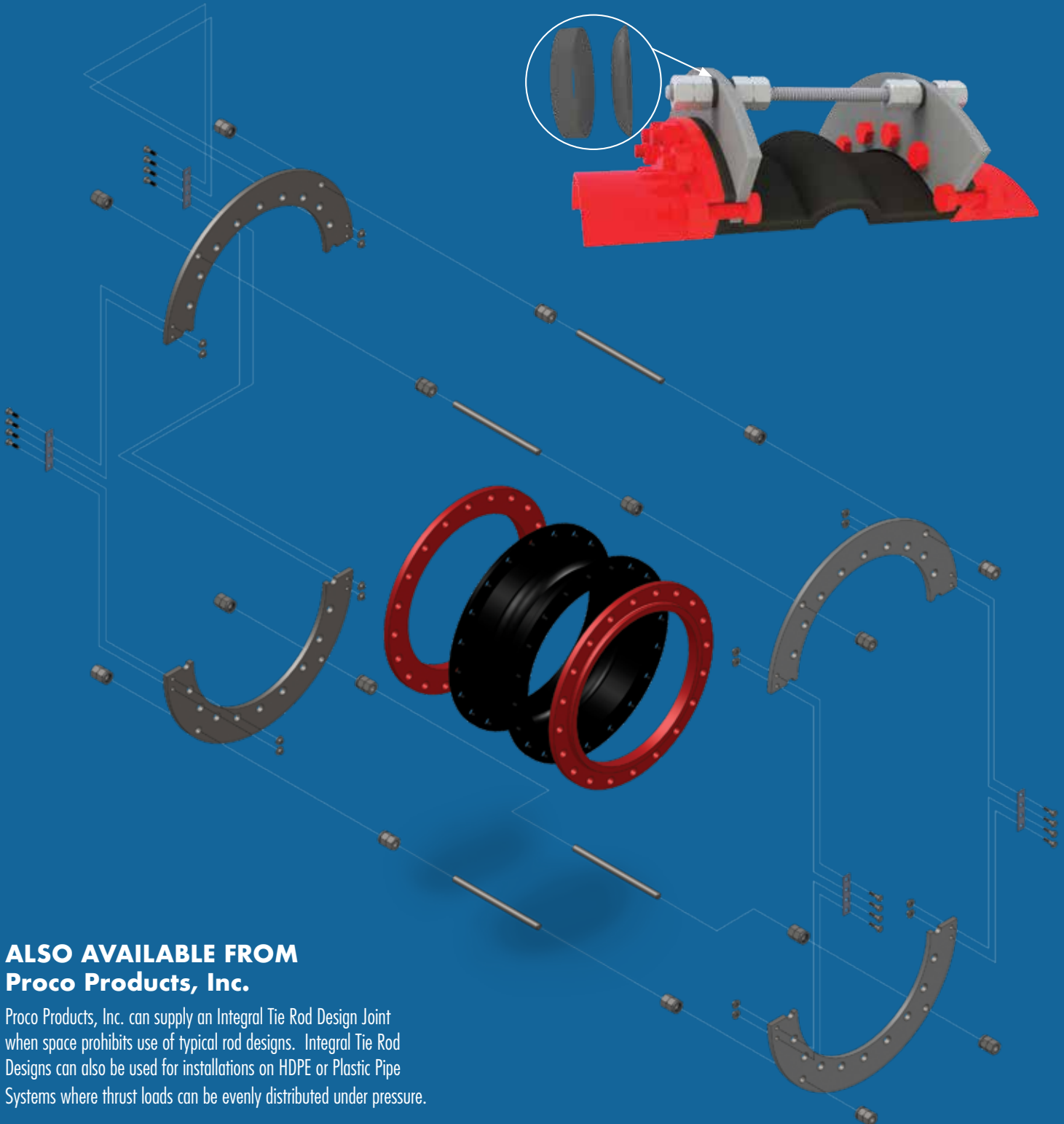


Figure 2

### Un-Anchored System Note:

Rod sets should be installed so that external nuts are snug against the plate at installation. Pressure thrust of the pipe system can cause expansion joint to over-elongate and reduce movement capabilities.





**ALSO AVAILABLE FROM  
Proco Products, Inc.**

Proco Products, Inc. can supply an Integral Tie Rod Design Joint when space prohibits use of typical rod designs. Integral Tie Rod Designs can also be used for installations on HDPE or Plastic Pipe Systems where thrust loads can be evenly distributed under pressure.



2431 North Wigwam Dr. (95205)  
P.O. Box 590 • Stockton, CA  
95201-0590 • USA

Toll-Free Phone: (800) 344-3246

Facsimile: (209) 943-0242

(209) 943-6088

email: sales@procoproducts.com

**NATIONWIDE AND CANADA**

**INTERNATIONAL**



Industrial Distributor Co-op



**REPRESENTED BY:**



**727-342-5088**

You can also email us at  
**GRP@goodyearrubberproducts.com**

# PROCO

*The Expansion Joint and Check Valve People*



RUBBER EXPANSION JOINT STYLE RC & RE

**GOODYEAR**  
RUBBER PRODUCTS, INC.

727-342-5088

You can also email us at  
[GRP@goodyearrubberproducts.com](mailto:GRP@goodyearrubberproducts.com)

# Proco's Headquarters

*Largest Inventory of Expansion Joints and Check Valves*



**GOODYEAR**  
RUBBER PRODUCTS, INC.

☎ 727-342-5088

You can also email us at  
[GRP@goodyearrubberproducts.com](mailto:GRP@goodyearrubberproducts.com)

# Proco Style RC & RE Rubber Joints

**Proco Style RC & RE** Rubber Expansion Joints are designed for piping systems to absorb pipe movements, relieve stress, reduce system noise/vibration, compensate for misalignment/offset and to protect rotating mechanical equipment against start-up surge forces.

**The Style RC-231** concentric rubber expansion joint is a single open wide arch type. Concentric in design, each flange-end shares the same common center-line.

**The Style RCFA-231** concentric rubber expansion joint is a single filled wide arch design generally used for slurry or abrasive services. This design has 50% less movement than the open arch design.

**The Style RE-231** eccentric rubber expansion joint is a single open wide arch type. Eccentric in design, the expansion joint body tapers on one side transitioning two different flange sizes.

**The Style REFA-231** eccentric rubber expansion joint is a single filled wide arch design generally used for slurry or abrasive services. This design has 50% less movement than the open arch design.

Also available from Proco Products, Inc. are the old narrow arch styles **RC-221, RCFA-221, RE-221** and **REFA-221** with shorter overall lengths.

## Features and Benefits:

### Absorbs Directional Movement

Thermal movements appear in any rigid pipe system due to temperature changes. The Style RC 231 and RE 231 wide arch joints allow for axial compression or axial extension, lateral deflection as well as angular and torsional movements. (Note: Rated movements in this publication are based on one plane movements. Multiple movement conditions are based on a multiple movement calculation. Contact Proco for information when designing multiple pipe movements.)

### Less Turbulence or Material Entrapment

The Style RC 231 and RE 231 expansion joints are manufactured with the integral rubber flange joining the body at a true 90° angle. This ensures the product will install snug against the mating pipe flange free of voids creating less turbulence in the pipe system. For applications where 20% or more solids are present, use the filled arch RCFA 231 and REFA 231 expansion joints for smooth bore transition with no possibility for material entrapment.

### Absorbs Vibration, Noise and Shock

The Proco Style RC 231 and RE 231 rubber expansion joints effectively dampen and insulate downstream piping against the transmission of noise and vibration generated by mechanical equipment. Noise and vibrations caused by equipment can cause stress in pipe, pipe guides, anchors and other equipment downstream. The Style RC 231 and RE 231 expansion joints will help relieve noise and vibration occurrences in a pipe system. Water hammer and pumping impulses can also cause strain, stress or shock to a piping system. Install the Style RC 231 and RE 231 to help compensate for these system pressure spikes.

### Compensates for Misalignment

Rubber expansion joints are commonly used by contractors and plant personnel to allow for slight pipe misalignment during installation of new piping and or replacement applications. (Although rubber expansion joints can be made with permanent offsets, it is suggested that piping misalignments be limited to no more than 1/2 the rated catalog movement. Contact Proco for resultant movement capability.)

### Wide Service Range and Less Weight

Engineered to operate up to 200 PSIG (nominal size dependent) or up to 250°F (elastomer dependent), the Series RC 231 and RE 231 can be specified for a wide range of piping system requirements. The Series RC 231 and RE 231 rubber expansion joints are constructed in various elastomers with rubber impregnated polyester tire cord and ASTM wire to make up the pressure restraining member. This lightweight design installs easily and costs less to ship.

### Material Identification

All RC 231 and RE 231 expansion joints are strip branded with cure dates and elastomer designations. All Neoprene Tube/Neoprene Cover (NN) and Nitrile Tube/Neoprene Cover (NP) elastomer designated joints meet the Coast Guard Requirements and conform to ASTM F 1123-87.

### Large Inventory

Proco Products, Inc. maintains one of the largest inventories of rubber expansion joints in the world. Please contact us for price and availability.

**Table 1: Available Materials • Temperatures**

For Specific Chemical Compatibilities, See: <b>PROCO "Chemical To Elastomer Guide"</b>					
Proco Material Code	Cover 1,2 Elastomer	Tube Elastomer	Maximum Operating Temp. °F (°C)	Branding Label Color	F.S.A. Material Class
<b>BB</b>	Chlorobutyl	Chlorobutyl	250° (121°)	Black	STD. III
<b>EE</b>	EPDM	EPDM	250° (121°)	Red	STD. III
<b>EQ</b>	EPDM	FDA-EPDM	250° (121°)	Red <sup>3</sup>	STD. II
<b>NH</b>	Neoprene	CSM	212° (100°)	Green	STD. II
<b>NN</b>	Neoprene	Neoprene	225° (107°)	Blue	STD. II
<b>NF</b>	Neoprene	FDA-Neoprene	225° (107°)	Blue <sup>3</sup>	STD. II
<b>NP</b>	Neoprene	Nitrile	212° (100°)	Yellow	STD. II
<b>NR</b>	Neoprene	Natural Rubber	180° (82°)	White	STD. I

Notes: All Products are reinforced with Polyester Tire Cord  
 1. Expansion Joint "Cover" can be coated with CSM UV Resistant Coating

**Protecting Piping and Equipment Systems from Stress/Motion**

# Style RC-231 Performance Data

**Table 2: Sizes • Movements • Operating Conditions • Weights**

Concentric Joint Size	Neutral Length		RC-231 Movement Capability <sup>1</sup> From Neutral Position:					Operating <sup>2</sup> Conditions			Weights <sup>3</sup> lbs/(kgs)	
	Min. (Inch)	Max. (Inch)	Axial Compression Inch/(mm)	Axial Extension Inch/(mm)	±Lateral Deflection Inch/(mm)	±Angular <sup>4</sup> Deflection Degrees	Torsional <sup>5</sup> Rotation Degrees	Thrust Factor <sup>6</sup> In <sup>2</sup> / (cm <sup>2</sup> )	Positive PSIG / (Bar)	Vacuum In. of <sup>7</sup> Hg/(mm of Hg)	Expansion Joint/Rings	Limit Rods <sup>8</sup>
2 X 1	8	18	1.0 (25)	0.5 (13)	0.5 (13)	25.0	2.0	4.83 (31)	200 (14)	26 (660)	5.0 (2.3)	7.0 (3.2)
2 X 1.5	8	18	1.0 (25)	0.5 (13)	0.5 (13)	25.0	2.0	5.85 (38)	200 (14)	26 (660)	6.0 (2.7)	7.0 (3.2)
2.5 X 1.5	8	18	1.0 (25)	0.5 (13)	0.5 (13)	20.0	2.0	6.97 (45)	200 (14)	26 (660)	6.0 (2.7)	8.0 (3.6)
2.5 X 2	8	18	1.0 (25)	0.5 (13)	0.5 (13)	20.0	2.0	8.19 (53)	200 (14)	26 (660)	6.0 (2.7)	8.0 (3.6)
3 X 1	8	18	1.4 (36)	0.7 (18)	0.5 (13)	24.0	2.0	6.97 (45)	200 (14)	26 (660)	7.0 (3.2)	8.0 (3.6)
3 X 1.5	8	18	1.4 (36)	0.7 (18)	0.5 (13)	24.0	2.0	8.19 (53)	200 (14)	26 (660)	8.0 (3.6)	8.0 (3.6)
3 X 2	8	18	1.4 (36)	0.7 (18)	0.5 (13)	24.0	2.0	9.51 (61)	200 (14)	26 (660)	9.0 (4.1)	8.0 (3.6)
3 X 2.5	8	18	1.4 (36)	0.7 (18)	0.5 (13)	24.0	2.0	10.92 (70)	200 (14)	26 (660)	9.0 (4.1)	8.0 (3.6)
4 X 2	8	18	1.4 (36)	0.7 (18)	0.5 (13)	18.0	2.0	12.43 (80)	200 (14)	26 (660)	10.0 (4.5)	8.0 (3.6)
4 X 2.5	8	18	1.4 (36)	0.7 (18)	0.5 (13)	18.0	2.0	14.05 (91)	200 (14)	26 (660)	11.0 (5.0)	8.0 (3.6)
4 X 3	8	18	1.4 (36)	0.7 (18)	0.5 (13)	18.0	2.0	15.76 (102)	200 (14)	26 (660)	12.0 (5.4)	8.0 (3.6)
5 X 3	8	18	1.6 (41)	0.8 (20)	0.5 (13)	17.0	2.0	21.06 (136)	190 (13)	26 (660)	15.0 (6.8)	12.0 (5.4)
5 X 4	8	18	1.6 (41)	0.8 (20)	0.5 (13)	17.0	2.0	25.33 (163)	190 (13)	26 (660)	16.0 (7.3)	12.0 (5.4)
6 X 2	8	18	1.6 (41)	0.8 (20)	0.5 (13)	14.0	2.0	21.06 (136)	190 (13)	26 (660)	15.0 (6.8)	14.0 (6.4)
6 X 2.5	8	18	1.6 (41)	0.8 (20)	0.5 (13)	14.0	2.0	23.15 (149)	190 (13)	26 (660)	15.0 (6.8)	14.0 (6.4)
6 X 3	8	18	1.6 (41)	0.8 (20)	0.5 (13)	14.0	2.0	25.33 (163)	190 (13)	26 (660)	17.0 (7.7)	14.0 (6.4)
6 X 4	8	18	1.6 (41)	0.8 (20)	0.5 (13)	14.0	2.0	29.98 (193)	190 (13)	26 (660)	17.0 (7.7)	14.0 (6.4)
6 X 5	8	18	1.6 (41)	0.8 (20)	0.5 (13)	14.0	2.0	35.03 (226)	190 (13)	26 (660)	18.0 (8.2)	14.0 (6.4)
8 X 3	8	18	1.6 (41)	0.8 (20)	0.5 (13)	11.0	2.0	35.03 (226)	190 (13)	26 (660)	19.0 (8.6)	22.0 (10.0)
8 X 4	8	18	1.6 (41)	0.8 (20)	0.5 (13)	11.0	2.0	40.47 (261)	190 (13)	26 (660)	19.0 (8.6)	21.0 (9.5)
8 X 5	8	18	1.6 (41)	0.8 (20)	0.5 (13)	11.0	2.0	46.30 (299)	190 (13)	26 (660)	20.0 (9.1)	22.0 (10.0)
8 X 6	8	18	1.6 (41)	0.8 (20)	0.5 (13)	11.0	2.0	52.53 (339)	190 (13)	26 (660)	21.0 (9.5)	23.0 (10.4)
10 X 5	10	18	1.6 (41)	0.8 (20)	0.5 (13)	8.0	2.0	59.14 (382)	190 (13)	26 (660)	25.0 (11.3)	31.0 (14.1)
10 X 6	10	18	1.6 (41)	0.8 (20)	0.5 (13)	8.0	2.0	66.15 (426)	190 (13)	26 (660)	26.0 (11.8)	31.0 (14.1)

**Table 2: Sizes • Movements • Operating Conditions • Weights**

Concentric Joint Size	Neutral Length		RC-231 Movement Capability <sup>1</sup> From Neutral Position:					Operating <sup>2</sup> Conditions			Weights <sup>3</sup> lbs/(kgs)	
	Nominal I.D. X I.D. (Inch)	Min. (Inch)	Max. (Inch)	Axial Compression Inch/(mm)	Axial Extension Inch/(mm)	±Lateral Deflection Inch/(mm)	±Angular <sup>4</sup> Deflection Degrees	Torsional <sup>5</sup> Rotation Degrees	Thrust Factor <sup>6</sup> In <sup>2</sup> / (cm <sup>2</sup> )	Positive PSIG / (Bar)	Vacuum In. of <sup>7</sup> Hg/(mm of Hg)	Expansion Joint/Rings
10 X 8	10	18	1.6 (41)	0.8 (20)	0.5 (13)	8.0	2.0	81.35 (525)	190 (13)	26 (660)	30.0 (13.6)	32.0 (14.5)
12 X 6	10	18	1.6 (41)	0.8 (20)	0.5 (13)	7.0	2.0	84.50 (545)	190 (13)	26 (660)	35.0 (15.9)	35.0 (15.9)
12 X 8	10	18	1.6 (41)	0.8 (20)	0.5 (13)	7.0	2.0	101.57 (655)	190 (13)	26 (660)	39.0 (17.7)	34.0 (15.4)
12 X 10	10	18	1.6 (41)	0.8 (20)	0.5 (13)	7.0	2.0	120.22 (776)	190 (13)	26 (660)	42.0 (19.1)	29.0 (13.2)
14 X 8	10	18	1.6 (41)	0.8 (20)	0.5 (13)	6.0	2.0	120.22 (776)	130 (9)	26 (660)	45.0 (20.4)	34.0 (15.4)
14 X 10	10	18	1.6 (41)	0.8 (20)	0.5 (13)	6.0	2.0	140.43 (906)	130 (9)	26 (660)	48.0 (21.8)	38.0 (17.2)
14 X 12	10	18	1.6 (41)	0.8 (20)	0.5 (13)	6.0	2.0	162.21 (1047)	130 (9)	26 (660)	55.0 (24.9)	31.0 (14.1)
16 X 10	10	18	1.6 (41)	0.8 (20)	0.5 (13)	5.0	2.0	162.21 (1047)	115 (8)	26 (660)	54.0 (24.5)	45.0 (20.4)
16 X 12	10	18	1.6 (41)	0.8 (20)	0.5 (13)	5.0	2.0	185.57 (1197)	115 (8)	26 (660)	60.0 (27.2)	42.0 (19.1)
16 X 14	10	18	1.6 (41)	0.8 (20)	0.5 (13)	5.0	2.0	210.49 (1358)	115 (8)	26 (660)	62.0 (28.1)	43.0 (19.5)
18 X 12	10	18	1.6 (41)	0.8 (20)	0.5 (13)	5.0	2.0	210.49 (1358)	115 (8)	26 (660)	64.0 (29.0)	48.0 (21.8)
18 X 14	10	18	1.6 (41)	0.8 (20)	0.5 (13)	5.0	2.0	236.98 (1529)	115 (8)	26 (660)	66.0 (29.9)	43.0 (19.5)
18 X 16	10	18	1.6 (41)	0.8 (20)	0.5 (13)	5.0	2.0	265.05 (1710)	115 (8)	26 (660)	70.0 (31.8)	39.0 (17.7)

**NOTES:**

- The RC-231 is available in a Filled Arch configuration. Known as the RCFA-231, this filled arch configuration is designed to eliminate flow turbulence and collection of solids for sludge, slurries or other heavy solids. The RCFA-231 filled arch product is manufactured with a seamless tube and is built as an integral part of the carcass. Although the arch filler is made with a lower durometer rubber, movement ratings of the RCFA-231 are 50% less than the movements listed in the above table.
- Pressure rating is based on 170° F operating temperature with a 4:1 safety factor. At higher temperatures, the pressure rating is reduced slightly. Hydrostatic testing at 1.5 times rated maximum catalogue pressure or design working pressure of pipe system for 10 minutes is available upon request.
- Weights are approximate and vary due to length.
- The degree of angular movement is based on the maximum rated extension.
- Torsional movement is expressed when the expansion joint is at neutral length.
- Calculation of Thrust (Thrust Factor). When expansion joints are installed in the pipeline, the static portion of the thrust is calculated as a product of the area of the I.D. of the arch of the expansion joint times the maximum pressure (design, test or surge) that will occur in the line. The result is a force expressed in pounds. Take design, surge or test pressure X thrust factor to calculate end thrust. For filled arch configuration use the I.D. of the pipe (D)<sup>2</sup> to calculate end thrust.
- Parts listed at 26" Hg / 660 mm Hg vacuum. Vacuum rating is based on neutral installed length, without external load. Products should not be installed "extended" on vacuum applications.
- Limit rod unit weight consists of one rod with washers, nuts, and two limit rod plates. Multiply number of limit rods needed for the application (as specified in the Fluid Sealing Association's Technical Handbook, Seventh Edition or table 4 in this manual) to determine correct weights.
- For plastic pipe systems utilizing the series RC consult Proco for design considerations.

**"Effective Area"**

Thrust Factor=

$$T = \frac{\pi}{4} (D)^2 (P)$$

T= Thrust  
P= PSI (Design, Test or Surge)  
D= Arch I.D.

# Style RE-231 Performance Data

**Table 3: Sizes • Movements • Operating Conditions • Weights**

Eccentric Joint Size	Neutral Length		RE-231 Movement Capability <sup>1</sup> From Neutral Position:					Operating <sup>2</sup> Conditions			Weights <sup>3</sup> lbs/(kgs)	
	Min. (Inch)	Max. (Inch)	Axial Compression Inch/(mm)	Axial Extension Inch/(mm)	±Lateral Deflection Inch/(mm)	±Angular <sup>4</sup> Deflection Degrees	Torsional <sup>5</sup> Rotation Degrees	Thrust Factor <sup>6</sup> In <sup>2</sup> / (cm <sup>2</sup> )	Positive PSIG / (Bar)	Vacuum In. of <sup>7</sup> Hg/(mm of Hg)	Expansion Joint/Rings	Limit Rods <sup>8</sup>
2 X 1	8	18	1.0 (25)	0.5 (13)	0.5 (13)	25.0	2.0	4.83 (31)	200 (14)	26 (660)	5.0 (2.3)	7.0 (3.2)
2 X 1.5	8	18	1.0 (25)	0.5 (13)	0.5 (13)	25.0	2.0	5.85 (38)	200 (14)	26 (660)	6.0 (2.7)	7.0 (3.2)
2.5 X 1.5	8	18	1.0 (25)	0.5 (13)	0.5 (13)	20.0	2.0	6.97 (45)	200 (14)	26 (660)	3.0 (1.4)	8.0 (3.6)
2.5 X 2	8	18	1.0 (25)	0.5 (13)	0.5 (13)	20.0	2.0	8.19 (53)	200 (14)	26 (660)	6.0 (2.7)	8.0 (3.6)
3 X 1	8	18	1.4 (36)	0.7 (18)	0.5 (13)	24.0	2.0	6.97 (45)	200 (14)	26 (660)	7.0 (3.2)	8.0 (3.6)
3 X 1.5	8	18	1.4 (36)	0.7 (18)	0.5 (13)	24.0	2.0	8.19 (53)	200 (14)	26 (660)	8.0 (3.6)	8.0 (3.6)
3 X 2	8	18	1.4 (36)	0.7 (18)	0.5 (13)	24.0	2.0	9.51 (61)	200 (14)	26 (660)	9.0 (4.1)	8.0 (3.6)
3 X 2.5	8	18	1.4 (36)	0.7 (18)	0.5 (13)	24.0	2.0	10.92 (70)	200 (14)	26 (660)	9.0 (4.1)	8.0 (3.6)
4 X 2	8	18	1.4 (36)	0.7 (18)	0.5 (13)	18.0	2.0	12.43 (80)	200 (14)	26 (660)	10.0 (4.5)	8.0 (3.6)
4 X 2.5	8	18	1.4 (36)	0.7 (18)	0.5 (13)	18.0	2.0	14.05 (91)	200 (14)	26 (660)	11.0 (5.0)	8.0 (3.6)
4 X 3	8	18	1.4 (36)	0.7 (18)	0.5 (13)	18.0	2.0	15.76 (102)	200 (14)	26 (660)	12.0 (5.4)	8.0 (3.6)
5 X 3	8	18	1.6 (41)	0.8 (20)	0.5 (13)	17.0	2.0	21.06 (136)	190 (13)	26 (660)	15.0 (6.8)	12.0 (5.4)
5 X 4	8	18	1.6 (41)	0.8 (20)	0.5 (13)	17.0	2.0	25.33 (163)	190 (13)	26 (660)	16.0 (7.3)	12.0 (5.4)
6 X 2	8	18	1.6 (41)	0.8 (20)	0.5 (13)	14.0	2.0	21.06 (136)	190 (13)	26 (660)	15.0 (6.8)	14.0 (6.4)
6 X 2.5	8	18	1.6 (41)	0.8 (20)	0.5 (13)	14.0	2.0	23.15 (149)	190 (13)	26 (660)	15.0 (6.8)	14.0 (6.4)
6 X 3	8	18	1.6 (41)	0.8 (20)	0.5 (13)	14.0	2.0	25.33 (163)	190 (13)	26 (660)	17.0 (7.7)	14.0 (6.4)
6 X 4	8	18	1.6 (41)	0.8 (20)	0.5 (13)	14.0	2.0	29.98 (193)	190 (13)	26 (660)	17.0 (7.7)	14.0 (6.4)
6 X 5	8	18	1.6 (41)	0.8 (20)	0.5 (13)	14.0	2.0	35.03 (226)	190 (13)	26 (660)	18.0 (8.2)	14.0 (6.4)
8 X 3	8	18	1.6 (41)	0.8 (20)	0.5 (13)	11.0	2.0	35.03 (226)	190 (13)	26 (660)	19.0 (8.6)	22.0 (10.0)
8 X 4	8	18	1.6 (41)	0.8 (20)	0.5 (13)	11.0	2.0	40.47 (261)	190 (13)	26 (660)	19.0 (8.6)	21.0 (9.5)
8 X 5	8	18	1.6 (41)	0.8 (20)	0.5 (13)	11.0	2.0	46.30 (299)	190 (13)	26 (660)	20.0 (9.1)	22.0 (10.0)
8 X 6	8	18	1.6 (41)	0.8 (20)	0.5 (13)	11.0	2.0	52.53 (339)	190 (13)	26 (660)	21.0 (9.5)	23.0 (10.4)
10 X 5	10	18	1.6 (41)	0.8 (20)	0.5 (13)	8.0	2.0	59.14 (382)	190 (13)	26 (660)	25.0 (11.3)	31.0 (14.1)
10 X 6	10	18	1.6 (41)	0.8 (20)	0.5 (13)	8.0	2.0	66.15 (426)	190 (13)	26 (660)	26.0 (11.8)	31.0 (14.1)

**Table 3: Sizes • Movements • Operating Conditions • Weights**

Eccentric Joint Size	Neutral Length		RE-231 Movement Capability <sup>1</sup> From Neutral Position:					Operating <sup>2</sup> Conditions			Weights <sup>3</sup> lbs/(kgs)	
	Nominal I.D. X I.D. (Inch)	Min. (Inch)	Max. (Inch)	Axial Compression Inch/(mm)	Axial Extension Inch/(mm)	±Lateral Deflection Inch/(mm)	±Angular <sup>4</sup> Deflection Degrees	Torsional <sup>5</sup> Rotation Degrees	Thrust Factor <sup>6</sup> In <sup>2</sup> / (cm <sup>2</sup> )	Positive PSIG / (bar)	Vacuum In. of <sup>7</sup> Hg/(mm of Hg)	Expansion Joint/Rings
10 X 8	10	18	1.6 (41)	0.8 (20)	0.5 (13)	8.0	2.0	81.35 (525)	190 (13)	26 (660)	30.0 (13.6)	32.0 (14.5)
12 X 6	12	18	1.6 (41)	0.8 (20)	0.5 (13)	7.0	2.0	84.50 (545)	190 (13)	26 (660)	35.0 (15.9)	35.0 (15.9)
12 X 8	10	18	1.6 (41)	0.8 (20)	0.5 (13)	7.0	2.0	101.57 (655)	190 (13)	26 (660)	39.0 (17.7)	34.0 (15.4)
12 X 10	10	18	1.6 (41)	0.8 (20)	0.5 (13)	7.0	2.0	120.22 (776)	190 (13)	26 (660)	42.0 (19.1)	29.0 (13.2)
14 X 8	12	18	1.6 (41)	0.8 (20)	0.5 (13)	6.0	2.0	120.22 (776)	130 (9)	26 (660)	45.0 (20.4)	34.0 (15.4)
14 X 10	12	18	1.6 (41)	0.8 (20)	0.5 (13)	6.0	2.0	140.43 (906)	130 (9)	26 (660)	48.0 (21.8)	38.0 (17.2)
14 X 12	10	18	1.6 (41)	0.8 (20)	0.5 (13)	6.0	2.0	162.21 (1047)	130 (9)	26 (660)	55.0 (24.9)	31.0 (14.1)
16 X 10	12	18	1.6 (41)	0.8 (20)	0.5 (13)	5.0	2.0	162.21 (1047)	115 (8)	26 (660)	54.0 (24.5)	45.0 (20.4)
16 X 12	12	18	1.6 (41)	0.8 (20)	0.5 (13)	5.0	2.0	185.57 (1197)	115 (8)	26 (660)	60.0 (27.2)	42.0 (19.1)
16 X 14	10	18	1.6 (41)	0.8 (20)	0.5 (13)	5.0	2.0	210.49 (1358)	115 (8)	26 (660)	62.0 (28.1)	43.0 (19.5)
18 X 12	12	18	1.6 (41)	0.8 (20)	0.5 (13)	5.0	2.0	210.49 (1358)	115 (8)	26 (660)	64.0 (29.0)	48.0 (21.8)
18 X 14	12	18	1.6 (41)	0.8 (20)	0.5 (13)	5.0	2.0	236.98 (1529)	115 (8)	26 (660)	66.0 (29.9)	43.0 (19.5)
18 X 16	10	18	1.6 (41)	0.8 (20)	0.5 (13)	5.0	2.0	265.05 (1710)	115 (8)	26 (660)	70.0 (31.8)	39.0 (17.7)

**NOTES:**

- The RE-231 is available in a Filled Arch configuration. Known as the REFA-231, this filled arch configuration is designed to eliminate flow turbulence and collection of solids for sludge, slurries or other heavy solids. The REFA-231 filled arch product is manufactured with a seamless tube and is built as an integral part of the carcass. Although the arch filler is made with a lower durometer rubber, movement ratings of the REFA-231 are 50% less than the movements listed in the above table.
- Pressure rating is based on 170° F operating temperature with a 4:1 safety factor. At higher temperatures, the pressure rating is reduced slightly. Hydrostatic testing at 1.5 times rated maximum catalogue pressure or design working pressure of pipe system for 10 minutes is available upon request.
- Weights are approximate and vary due to length.
- The degree of angular movement is based on the maximum rated extension.
- Torsional movement is expressed when the expansion joint is at neutral length.
- Calculation of Thrust (Thrust Factor). When expansion joints are installed in the pipeline, the static portion of the thrust is calculated as a product of the area of the I.D. of the arch of the expansion joint times the maximum pressure (design, test or surge) that will occur in the line. The result is a force expressed in pounds. Take design, surge or test pressure X thrust factor to calculate end thrust. For filled arch configuration use the I.D. of the pipe (D)<sup>2</sup> to calculate end thrust.
- Parts listed at 26" Hg / 660 mm Hg vacuum. Vacuum rating is based on neutral installed length, without external load. Products should not be installed "extended" on vacuum applications.
- Limit rod unit weight consists of one rod with washers, nuts, and two limit rod plates. Multiply number of limit rods needed for the application (as specified in the Fluid Sealing Association's Technical Handbook, Seventh Edition or table 4 in this manual) to determine correct weights.
- For plastic pipe systems utilizing the series RE, consult Proco for design considerations.

"Effective Area"  
 Thrust Factor=  

$$T = \frac{\pi}{4} (D)^2 (P)$$
 T= Thrust  
 P= PSI (Design, Test or Surge)  
 D= Arch I.D.

# Style RC & RE 221 Performance Data

Table 4: Sizes • Movements • Operating Conditions • Weights												
Joint Size	Neutral Length		RC & RE 221 Movement Capability <sup>1</sup> from Neutral Position					Operating <sup>2</sup> Conditions			Weights <sup>3</sup> lbs/(kgs)	
	Nominal I.D. X I.D. (Inch)	RC (Inch)	RE (Inch)	Axial Compression Inch/(mm)	Axial Extension Inch/(mm)	±Lateral Deflection Inch/(mm)	±Angular <sup>4</sup> Deflection Degrees	Torsional <sup>5</sup> Rotation Degrees	Thrust Factor <sup>6</sup> In <sup>2</sup> / (cm <sup>2</sup> )	Positive PSIG / (Bar)	Vacuum In. of <sup>7</sup> Hg/(mm of Hg)	Expansion Joint/Rings
2 X 1	6	6	0.5 (13)	.25 (6.35)	0.5 (13)	18.4	2.0	12.69 (81)	200 (14)	26 (660)	5.0 (1.3)	7.0 (3.2)
2 X 1.5	6	6	0.5 (13)	.25 (6.35)	0.5 (13)	15.9	2.0	14.32 (92)	200 (14)	26 (660)	6.0 (2.7)	7.0 (3.2)
2 X 1.5	X	7	0.5 (13)	.25 (6.35)	0.5 (13)	14.1	2.0	16.04 (103)	200 (14)	26 (660)	6.0 (2.7)	7.0 (3.2)
2.5 X 1.5	6	6	0.5 (13)	.25 (6.35)	0.5 (13)	14.1	2.0	16.04 (103)	200 (14)	26 (660)	6.0 (2.7)	8.0 (3.6)
2.5 X 2	6	6	0.5 (13)	.25 (6.35)	0.5 (13)	12.5	2.0	17.87 (115)	200 (14)	26 (660)	6.0 (2.7)	8.0 (3.6)
2.5 X 2	X	7	0.5 (13)	.25 (6.35)	0.5 (13)	12.5	2.0	17.87 (115)	200 (14)	26 (660)	6.0 (2.7)	8.0 (3.6)
3.0 X 1.5	6	6	0.5 (13)	.25 (6.35)	0.5 (13)	12.5	2.0	17.87 (115)	200 (14)	26 (660)	8.0 (3.6)	8.0 (3.6)
3.0 X 2	6	6	0.5 (13)	.25 (6.35)	0.5 (13)	11.3	2.0	19.79 (128)	200 (14)	26 (660)	9.0 (4.1)	8.0 (3.6)
3.0 X 2.5	6	6	0.5 (13)	.25 (6.35)	0.5 (13)	10.3	2.0	21.81 (141)	200 (14)	26 (660)	9.0 (4.1)	8.0 (3.6)
4.0 X 2	6	6	0.5 (13)	.25 (6.35)	0.5 (13)	9.5	2.0	23.93 (154)	200 (14)	26 (660)	10.0 (4.5)	8.0 (3.6)
4.0 X 2	7	7	0.5 (13)	.25 (6.35)	0.5 (13)	9.5	2.0	23.93 (154)	200 (14)	26 (660)	10.0 (4.5)	8.0 (3.6)
4 X 2.5	6	6	0.5 (13)	.25 (6.35)	0.5 (13)	8.7	2.0	26.14 (169)	200 (14)	26 (660)	11.0 (5.0)	8.0 (3.6)
4 X 2.5	7	7	0.5 (13)	.25 (6.35)	0.5 (13)	8.7	2.0	26.14 (169)	200 (14)	26 (660)	11.0 (5.0)	8.0 (3.6)
4 X 3	6	6	0.5 (13)	.25 (6.35)	0.5 (13)	8.1	2.0	28.46 (189)	200 (14)	26 (660)	12.0 (5.4)	8.0 (3.6)
4 X 3	7	7	0.5 (13)	.25 (6.35)	0.5 (13)	8.1	2.0	28.46 (189)	200 (14)	26 (660)	12.0 (5.4)	8.0 (3.6)
5 X 3	6	X	0.5 (13)	.25 (6.35)	0.5 (13)	7.1	2.0	33.38 (215)	190 (13)	26 (660)	15.0 (6.8)	12.0 (5.4)
5 X 4	6	6	0.5 (13)	.25 (6.35)	0.5 (13)	6.3	2.0	38.70 (250)	190 (13)	26 (660)	16.0 (7.3)	12.0 (5.4)
6 X 2.5	6	X	0.5 (13)	.25 (6.35)	0.5 (13)	6.7	2.0	35.99 (232)	190 (13)	26 (660)	15.0 (6.8)	14.0 (6.4)
6 X 3	6	6	0.5 (13)	.25 (6.35)	0.5 (13)	6.3	2.0	38.70 (250)	190 (13)	26 (660)	17.0 (7.7)	14.0 (6.4)

See Notes Page 9

**Table 4: Sizes • Movements • Operating Conditions • Weights**

Joint Size	Neutral Length		RC & RE 221 Movement Capability <sup>1</sup> from Neutral Position					Operating <sup>2</sup> Conditions			Weights <sup>3</sup> lbs/(kgs)	
	Nominal I.D. X I.D. (Inch)	RC (Inch)	RE (Inch)	Axial Compression Inch/(mm)	Axial Extension Inch/(mm)	±Lateral Deflection Inch/(mm)	±Angular <sup>4</sup> Deflection Degrees	Torsional <sup>5</sup> Rotation Degrees	Thrust Factor <sup>6</sup> In <sup>2</sup> / (cm <sup>2</sup> )	Positive PSIG / (bar)	Vacuum In. of <sup>7</sup> Hg/(mm of Hg)	Expansion Joint/Rings
6 X 4	6	6	0.5 (13)	.25 (6.35)	0.5 (13)	5.7	2.0	44.41 (287)	190 (13)	26 (660)	17.0 (7.7)	14.0 (6.4)
6 X 5	6	6	0.5 (13)	.25 (6.35)	0.5 (13)	5.2	2.0	50.51 (326)	190 (13)	26 (660)	18.0 (8.20)	14.0 (6.4)
8 X 3	6	X	.75 (19)	.375 (9.5)	0.5 (13)	7.8	2.0	56.64 (365)	190 (13)	26 (660)	19.0 (8.6)	22.0 (10.0)
8 X 4	6	6	.75 (19)	.375 (9.5)	0.5 (13)	7.1	2.0	63.51 (410)	190 (13)	26 (660)	19.0 (8.6)	21.0 (9.5)
8 X 5	6	X	.75 (19)	.375 (9.5)	0.5 (13)	6.6	2.0	70.77 (457)	190 (13)	26 (660)	20.0 (9.1)	22.0 (10.0)
8 X 6	6	6	.75 (19)	.375 (9.5)	0.5 (13)	6.1	2.0	78.42 (506)	190 (13)	26 (660)	21.0 (9.5)	23.0 (10.4)
10 X 5	8	X	.75 (19)	.375 (9.5)	0.5 (13)	5.7	2.0	86.46 (558)	190 (13)	26 (660)	25.0 (11.3)	31.0 (14.1)
10 X 6	8	8	.75 (19)	.375 (9.5)	0.5 (13)	5.4	2.0	94.90 (612)	190 (13)	26 (660)	26.0 (11.8)	31.0 (14.1)
10 X 6	X	9	.75 (19)	.375 (9.5)	0.5 (13)	5.4	2.0	94.90 (612)	190 (13)	26 (660)	26.0 (11.8)	31.0 (14.1)
10 X 8	6	6	.75 (19)	.375 (9.5)	0.5 (13)	4.8	2.0	112.95 (729)	190 (13)	26 (660)	30.0 (13.6)	32.0 (14.5)
10 X 8	8	8	.75 (19)	.375 (9.5)	0.5 (13)	4.8	2.0	112.95 (729)	190 (13)	26 (660)	30.0 (13.6)	32.0 (14.5)
12 X 6	8	X	.75 (19)	.375 (9.5)	0.5 (13)	4.8	2.0	112.95 (729)	190 (13)	26 (660)	35.0 (15.9)	35.0 (15.9)
12 X 8	6	8	.75 (19)	.375 (9.5)	0.5 (13)	4.3	2.0	132.57 (855)	190 (13)	26 (660)	39.0 (17.7)	34.0 (15.4)
12 X 8	8	X	.75 (19)	.375 (9.5)	0.5 (13)	4.3	2.0	132.57 (855)	190 (13)	26 (660)	39.0 (17.7)	34.0 (15.4)
12 X 10	8	8	.75 (19)	.375 (9.5)	0.5 (13)	3.9	2.0	153.77 (992)	190 (13)	26 (660)	42.0 (19.1)	29.0 (13.2)
14 X 8	8	X	.75 (19)	.375 (9.5)	0.5 (13)	3.9	2.0	177.09 (1143)	130 (9)	26 (660)	45.0 (20.4)	34.0 (15.4)
14 X 10	8	8	.75 (19)	.375 (9.5)	0.5 (13)	3.6	2.0	201.46 (1300)	130 (9)	26 (660)	48.0 (21.8)	38.0 (17.2)
14 X 10	X	10	.75 (19)	.375 (9.5)	0.5 (13)	3.6	2.0	201.46 (1300)	130 (9)	26 (660)	48.0 (21.8)	38.0 (17.2)
14 X 12	8	8	.75 (19)	.375 (9.5)	0.5 (13)	3.3	2.0	227.40 (1467)	130 (9)	26 (660)	55.0 (24.9)	31.0 (14.1)

See Notes Page 9

# Style RC & RE 221 Performance Data

Table 4: Sizes • Movements • Operating Conditions • Weights												
Joint Size	Neutral Length		RC & RE 221 Movement Capability <sup>1</sup> from Neutral Position					Operating Conditions			Weights lbs/(kgs)	
	Nominal I.D. X I.D. (Inch)	RC (Inch)	RE (Inch)	Axial Compression Inch/(mm)	Axial Extension Inch/(mm)	±Lateral Deflection Inch/(mm)	±Angular Deflection Degrees	Torsional Rotation Degrees	Thrust Factor <sup>6</sup> In <sup>2</sup> / (cm <sup>2</sup> )	Positive PSIG / (Bar)	Vacuum In. of <sup>7</sup> Hg / (mm of Hg)	Expansion Joint/Rings
16 X 10	8	X	.75 (19)	.375 (9.5)	0.5 (13)	3.3	2.0	227.40 (1467)	110 (7.6)	26 (660)	54.0 (24.5)	45.0 (20.4)
16 X 12	8	10	.75 (19)	.375 (9.5)	0.5 (13)	3.1	2.0	254.92 (1645)	110 (7.6)	26 (660)	60.0 (27.2)	42.0 (19.1)
16 X 14	8	8	.75 (19)	.375 (9.5)	0.5 (13)	2.9	2.0	284.00 (1832)	110 (7.6)	26 (660)	62.0 (28.1)	43.0 (19.5)
18 X 12	8	X	.75 (19)	.375 (9.5)	0.5 (13)	2.9	2.0	284.00 (1832)	110 (7.6)	26 (660)	64.0 (29.0)	48.0 (21.8)
18 X 14	8	X	.75 (19)	.375 (9.5)	0.5 (13)	2.7	2.0	314.65 (2030)	118 (8.1)	26 (660)	66.0 (29.9)	43.0 (19.5)
18 X 16	8	8	.75 (19)	.375 (9.5)	0.5 (13)	2.5	2.0	346.88 (2238)	110 (7.6)	26 (660)	70.0 (31.8)	39.0 (17.7)

## NOTES:

- The RC-221 or RE-221 is available in a Filled Arch configuration. Known as the RCFA-221 or REFA-221, these filled arch configurations are designed to eliminate flow turbulence and collection of solids for sludge, slurries or other heavy solids. The RCFA-221 or REFA-221 filled arch products are manufactured with a seamless tube and are built as an integral part of the carcass. Although the arch filler is made with a lower durometer rubber, movement ratings of the RCFA-221 or REFA-221 are 50% less than the movements listed in the above table.
- Pressure rating is based on 170° F operating temperature with a 4:1 safety factor. At higher temperatures, the pressure rating is reduced slightly. Hydrostatic testing at 1.5 times rated maximum catalogue pressure or design working pressure of pipe system for 10 minutes is available upon request.
- Weights are approximate and vary due to length.
- The degree of angular movement is based on the maximum rated extension.
- Torsional movement is expressed when the expansion joint is at neutral length.
- Calculation of Thrust (Thrust Factor). When expansion joints are installed in the pipeline, the static portion of the thrust is calculated as a product of the area of the I.D. of the arch of the expansion joint times the maximum pressure (design, test or surge) that will occur in the line. The result is a force expressed in pounds. Take design, surge or test pressure X thrust factor to calculate end thrust. For filled arch configuration use the I.D. of the pipe (D)<sup>2</sup> to calculate end thrust.
- Parts listed at 26" Hg / 660 mm Hg vacuum. Vacuum rating is based on neutral installed length, without external load. Products should not be installed "extended" on vacuum applications.
- Limit rod unit weight consists of one rod with washers, nuts, and two limit rod plates. Multiply number of limit rods needed for the application (as specified in the Fluid Sealing Association's Technical Handbook, Seventh Edition or table 4 in this manual) to determine correct weights.
- For plastic pipe systems utilizing the series RC/RE, consult Proco for design considerations.
- Larger sizes not shown in brochure are available upon request.

### "Effective Area"

#### Thrust Factor=

$$T = \frac{\pi}{4} (D)^2 (P)$$

T= Thrust  
P= PSI (Design, Test or Surge)  
D= Arch I.D.

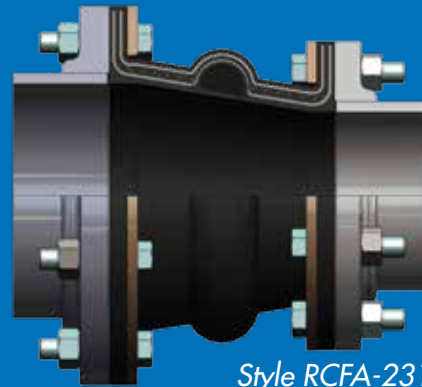


# Style RC & RE

## Proco Style RC



Style RC-231



Style RCFA-231

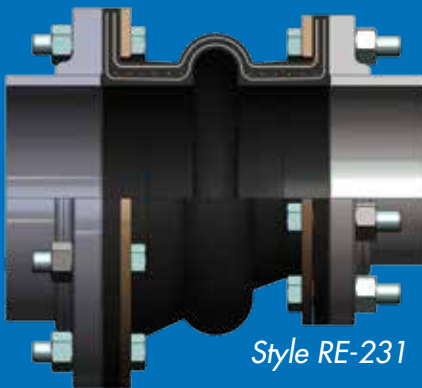


Style RC-221

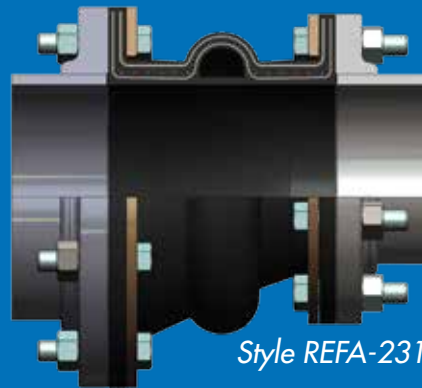


Style RCFA-221

## Proco Style RE



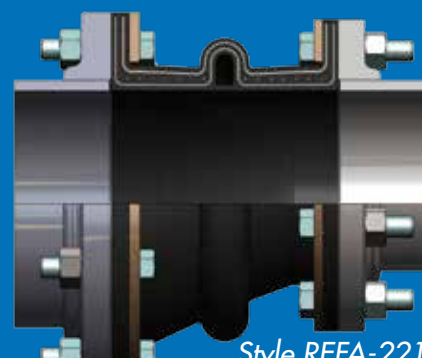
Style RE-231



Style REFA-231



Style RE-221



Style REFA-221

# Style RC & RE Drilling Chart

Table 5: Flange Drillings									Thickness of Materials for PROCO Rubber Expansion Joints						Control Unit Plate Detail	
Joint Size Available	Standard Drilling for PROCO Series RC or RE <sup>2</sup> Rubber Expansion Joints 125/150# Flange Dimensions								Material Thickness <sup>1</sup> for Bolt Length Requirements							
	Large End				Small End				Concentric & Eccentric Neutral Length (Inch)	Retaining Rings Thickness Inch / (mm)	Large End	Small End	Adjacent Mating <sup>3</sup> Flange Thickness	Large End		
Nominal I.D. X I.D. (Inch)	Flange O.D. Inch/(mm)	Bolt Circle Inch/(mm)	No. of Holes	Size of Holes Inch/(mm)	Flange O.D. Inch/(mm)	Bolt Circle Inch/(mm)	No. of Holes	Size of Holes Inch/(mm)			Rubber Flange Thickness Inch / (mm)	Max. Control <sup>4</sup> Rod Plate Thickness Inch / (mm)				
2 X 1	6.00 (152.40)	4.750 (120.65)	4	0.750 (19.1)	4.25 (107.95)	3.125 (79.38)	4	0.625 (15.9)	0.375 (9.53)	0.472 (11.99)	0.472 (11.99)	C U S T O M E R  T O S P E C I F Y  F L A N G E  T H I C K N E S S	0.375 (9.53)	0.375 (9.53)	10.125 (257.2)	0.625 (15.9)
2 X 1.5	6.00 (152.40)	4.750 (120.65)	4	0.750 (19.1)	5.00 (127.00)	3.875 (98.43)	4	0.625 (15.9)	0.375 (9.53)	0.472 (11.99)	0.472 (11.99)		0.375 (9.53)	0.375 (9.53)	10.125 (257.2)	0.625 (15.9)
2.5 X 1.5	7.00 (177.80)	5.500 (139.70)	4	0.750 (19.1)	5.00 (127.00)	3.875 (98.43)	4	0.625 (15.9)	0.375 (9.53)	0.472 (11.99)	0.472 (11.99)		0.375 (9.53)	0.375 (9.53)	11.125 (282.6)	0.625 (15.9)
2.5 X 2	7.00 (177.80)	5.500 (139.70)	4	0.750 (19.1)	6.00 (152.40)	4.750 (120.65)	4	0.750 (19.1)	0.375 (9.53)	0.472 (11.99)	0.472 (11.99)		0.375 (9.53)	0.375 (9.53)	11.125 (282.6)	0.625 (15.9)
3.0 X 1.5	7.50 (190.50)	6.000 (152.40)	4	0.750 (19.1)	5.00 (127.00)	3.875 (98.43)	4	0.625 (15.9)	0.375 (9.53)	0.472 (11.99)	0.472 (11.99)		0.375 (9.53)	0.375 (9.53)	11.625 (295.3)	0.625 (15.9)
3.0 X 2	7.50 (190.50)	6.000 (152.40)	4	0.750 (19.1)	6.00 (152.40)	4.750 (120.65)	4	0.750 (19.1)	0.375 (9.53)	0.472 (11.99)	0.472 (11.99)		0.375 (9.53)	0.375 (9.53)	11.625 (295.3)	0.625 (15.9)
3.0 X 2.5	7.50 (190.50)	6.000 (152.40)	4	0.750 (19.1)	7.00 (177.80)	5.500 (139.70)	4	0.750 (19.1)	0.375 (9.53)	0.472 (11.99)	0.472 (11.99)		0.375 (9.53)	0.375 (9.53)	11.625 (295.3)	0.625 (15.9)
4.0 X 2	9.00 (228.60)	7.500 (190.50)	8	0.750 (19.1)	6.00 (152.40)	4.750 (120.65)	4	0.750 (19.1)	0.375 (9.53)	0.472 (11.99)	0.472 (11.99)		0.375 (9.53)	0.375 (9.53)	13.125 (333.4)	0.625 (15.9)
4 X 2.5	9.00 (228.60)	7.500 (190.50)	8	0.750 (19.1)	7.00 (177.80)	5.500 (139.70)	4	0.750 (19.1)	0.375 (9.53)	0.472 (11.99)	0.472 (11.99)		0.375 (9.53)	0.375 (9.53)	13.125 (333.4)	0.625 (15.9)
4 X 3	9.00 (228.60)	7.500 (190.50)	8	0.750 (19.1)	7.50 (190.50)	6.000 (152.40)	4	0.750 (19.1)	0.375 (9.53)	0.472 (11.99)	0.472 (11.99)		0.375 (9.53)	0.375 (9.53)	13.125 (333.4)	0.625 (15.9)
5 X 3	10.00 (254.00)	8.500 (215.90)	8	0.875 (22.2)	7.50 (190.50)	6.000 (152.40)	4	0.750 (19.1)	0.375 (9.53)	0.551 (14.00)	0.472 (11.99)		0.500 (12.70)	0.375 (9.53)	14.125 (358.8)	0.625 (15.9)
5 X 4	10.00 (254.00)	8.500 (215.90)	8	0.875 (22.2)	9.00 (228.60)	7.500 (190.50)	8	0.750 (19.1)	0.375 (9.53)	0.551 (14.00)	0.472 (11.99)		0.500 (12.70)	0.375 (9.53)	14.125 (358.8)	0.625 (15.9)
6 X 2.5	11.00 (279.40)	9.500 (241.30)	8	0.875 (22.2)	7.00 (177.80)	5.500 (139.70)	4	0.750 (19.1)	0.375 (9.53)	0.551 (14.00)	0.472 (11.99)		0.500 (12.70)	0.375 (9.53)	15.125 (384.2)	0.625 (15.9)
6 X 3	11.00 (279.40)	9.500 (241.30)	8	0.875 (22.2)	7.50 (190.50)	6.000 (152.40)	4	0.750 (19.1)	0.375 (9.53)	0.551 (14.00)	0.472 (11.99)		0.500 (12.70)	0.375 (9.53)	15.125 (384.2)	0.625 (15.9)
6 X 4	11.00 (279.40)	9.500 (241.30)	8	0.875 (22.2)	9.00 (228.60)	7.500 (190.50)	8	0.750 (19.1)	0.375 (9.53)	0.551 (14.00)	0.472 (11.99)		0.500 (12.70)	0.472 (11.99)	15.125 (384.2)	0.625 (15.9)

Table 5: Flange Drillings									Thickness of Materials for PROCO Rubber Expansion Joints						Control Unit Plate Detail	
Joint Size Available	Standard Drilling for PROCO Series RC or RE <sup>2</sup> Rubber Expansion Joints 125/150# Flange Dimensions								Material Thickness <sup>1</sup> for Bolt Length Requirements						Control Unit Plate Detail	
	Large End				Small End				Concentric & Eccentric Neutral Length Thickness Inch / (mm)	Retaining Rings Thickness Inch / (mm)	Large End	Small End	Adjacent Matting <sup>3</sup> Flange Thickness	Large End		
Nominal I.D. X I.D. (Inch)	Flange O.D. Inch/(mm)	Bolt Circle Inch/(mm)	No. of Holes	Size of Holes Inch/(mm)	Flange O.D. Inch/(mm)	Bolt Circle Inch/(mm)	No. of Holes	Size of Holes Inch/(mm)			Rubber Flange Thickness Inch / (mm)	Max. Control <sup>4</sup> Rod Plate Thickness Inch / (mm)		Control Rod Plate O.D. <sup>6</sup> Inch / (mm)	Maximum <sup>7</sup> Rod Diameter Inch / (mm)	
6 X 5	11.00 (279.40)	9.500 (241.30)	8	0.875 (22.2)	10.00 (254.00)	8.500 (215.90)	8	0.875 (22.2)	0.375 (9.53)	0.551 (14.00)	0.472 (11.99)	CUSTOMER TO SPECIFY FLANGE	0.500 (12.70)	0.551 (14.00)	15.125 (384.2)	0.625 (15.9)
8 X 3	13.50 (342.90)	11.75 (298.45)	8	0.875 (22.2)	7.50 (190.50)	6.000 (152.40)	4	0.750 (19.1)	0.375 (9.53)	0.630 (16.00)	0.472 (11.99)		0.750 (19.05)	0.472 (11.99)	19.125 (485.8)	1.000 (25.4)
8 X 4	13.50 (342.90)	11.75 (298.45)	8	0.875 (22.2)	9.00 (228.60)	7.500 (190.50)	8	0.750 (19.1)	0.375 (9.53)	0.630 (16.00)	0.472 (11.99)		0.750 (19.05)	0.472 (11.99)	19.125 (485.8)	1.000 (25.4)
8 X 5	13.50 (342.90)	11.75 (298.45)	8	0.875 (22.2)	10.00 (254.00)	8.500 (215.90)	8	0.875 (22.2)	0.375 (9.53)	0.630 (16.00)	0.551 (14.00)		0.750 (19.05)	0.551 (14.00)	19.125 (485.8)	1.000 (25.4)
8 X 6	13.50 (342.90)	11.75 (298.45)	8	0.875 (22.2)	11.00 (279.40)	9.500 (241.30)	8	0.875 (22.2)	0.375 (9.53)	0.630 (16.00)	0.551 (14.00)		0.750 (19.05)	0.551 (14.00)	19.125 (485.8)	1.000 (25.4)
10 X 5	16.00 (406.40)	14.25 (361.95)	12	1.000 (25.4)	10.00 (254.00)	8.500 (215.90)	8	0.875 (22.2)	0.375 (9.53)	0.630 (16.00)	0.551 (14.00)		0.750 (19.05)	0.551 (14.00)	21.125 (549.3)	1.000 (25.4)
10 X 6	16.00 (406.40)	14.25 (361.95)	12	1.000 (25.4)	11.00 (279.40)	9.500 (241.30)	8	0.875 (22.2)	0.375 (9.53)	0.630 (16.00)	0.551 (14.00)		0.750 (19.05)	0.551 (14.00)	21.125 (549.3)	1.000 (25.4)
10 X 8	16.00 (406.40)	14.25 (361.95)	12	1.000 (25.4)	13.50 (342.90)	11.750 (298.45)	8	0.875 (22.2)	0.375 (9.53)	0.630 (16.00)	0.630 (16.00)		0.750 (19.05)	0.630 (16.00)	21.125 (549.3)	1.000 (25.4)
12 X 6	19.00 (482.60)	17.00 (431.80)	12	1.000 (25.4)	11.00 (279.40)	9.500 (241.30)	8	0.875 (22.2)	0.375 (9.53)	0.748 (19.00)	0.630 (16.00)		0.750 (19.05)	0.551 (14.00)	24.625 (625.5)	1.000 (25.4)
12 X 8	19.00 (482.60)	17.00 (431.80)	12	1.000 (25.4)	13.50 (342.90)	11.750 (298.45)	8	0.875 (22.2)	0.375 (9.53)	0.748 (19.00)	0.630 (16.00)		0.750 (19.05)	0.631 (16.00)	24.625 (625.5)	1.000 (25.4)
12 X 10	19.00 (482.60)	17.00 (431.80)	12	1.000 (25.4)	16.00 (406.40)	14.250 (361.95)	12	1.000 (25.4)	0.375 (9.53)	0.748 (19.00)	0.630 (16.00)		0.750 (19.05)	0.631 (16.00)	24.625 (625.5)	1.000 (25.4)
14 X 8	21.00 (533.40)	18.75 (476.25)	12	1.125 (28.6)	13.50 (342.90)	11.750 (298.45)	8	0.875 (22.2)	0.375 (9.53)	0.866 (22.00)	0.630 (16.00)		0.750 (19.05)	0.631 (16.00)	26.625 (676.3)	1.000 (25.4)
14 X 10	21.00 (533.40)	18.75 (476.25)	12	1.125 (28.6)	16.00 (406.40)	14.250 (361.95)	12	1.000 (25.4)	0.375 (9.53)	0.866 (22.00)	0.630 (16.00)		0.750 (19.05)	0.631 (16.00)	26.625 (676.3)	1.000 (25.4)
14 X 12	21.00 (533.40)	18.75 (476.25)	12	1.125 (28.6)	19.00 (482.60)	17.000 (431.80)	12	1.000 (25.4)	0.375 (9.53)	0.866 (22.00)	0.748 (19.00)		0.750 (19.05)	0.750 (19.05)	26.625 (676.3)	1.000 (25.4)

See Notes Page 13

# Style RC & RE Drilling Chart

Table 5: Flange Drillings									Thickness of Materials for PROCO Rubber Expansion Joints						Control Unit Plate Detail		
Joint Size Available	Standard Drilling for PROCO Series RC or RE <sup>2</sup> Rubber Expansion Joints 125/150# Flange Dimensions								Material Thickness <sup>1</sup> for Bolt Length Requirements								
	Large End				Small End				Concentric & Eccentric Neutral Length Thickness Inch / (mm)	Retaining Rings Thickness Inch / (mm)	Large End	Small End	Adjacent Mating <sup>3</sup> Flange Thickness	Large End			Small End
Nominal I.D. X I.D. (Inch)	Flange O.D. Inch / (mm)	Bolt Circle Inch / (mm)	No. of Holes	Size of Holes Inch / (mm)	Flange O.D. Inch / (mm)	Bolt Circle Inch / (mm)	No. of Holes	Size of Holes Inch / (mm)			Rubber Flange Thickness Inch / (mm)	Max. Control <sup>4</sup> Rod Plate Thickness Inch / (mm)		Control Rod Plate O.D. <sup>6</sup> Inch / (mm)	Maximum <sup>7</sup> Rod Diameter Inch / (mm)		
16 X 10	23.50 (596.90)	21.25 (539.75)	16	1.125 (28.6)	16.00 (406.40)	14.250 (361.95)	12	1.000 (25.4)	REFER TO TABLES 2, 3 & 4	0.375 (9.53)	0.866 (22.00)	0.630 (16.00)	CUSTOMER TO SPECIFY MATING FLANGE THICKNESS	0.750 (19.05)	0.750 (19.05)	30.125 (765.2)	1.250 (31.8)
16 X 12	23.50 (596.90)	21.25 (539.75)	16	1.125 (28.6)	19.00 (482.60)	17.000 (431.80)	12	1.000 (25.4)		0.375 (9.53)	0.866 (22.00)	0.630 (16.00)		0.750 (19.05)	0.750 (19.05)	30.125 (765.2)	1.250 (31.8)
16 X 14	23.50 (596.90)	21.25 (539.75)	16	1.125 (28.6)	21.00 (533.40)	18.750 (476.25)	12	1.125 (28.6)		0.375 (9.53)	0.866 (22.00)	0.866 (22.00)		0.750 (19.05)	0.750 (19.05)	30.125 (765.2)	1.250 (31.8)
18 X 12	25.00 (635.00)	22.75 (577.85)	16	1.250 (31.8)	19.00 (482.60)	17.000 (431.80)	12	1.000 (25.4)		0.375 (9.53)	0.866 (22.00)	0.630 (16.00)		0.750 (19.05)	0.750 (19.05)	31.625 (803.3)	1.250 (31.8)
18 X 14	25.00 (635.00)	22.75 (577.85)	16	1.250 (31.8)	21.00 (533.40)	18.750 (476.25)	12	1.125 (28.6)		0.375 (9.53)	0.866 (22.00)	0.866 (22.00)		0.750 (19.05)	0.750 (19.05)	31.625 (803.3)	1.250 (31.8)
18 X 16	25.00 (635.00)	22.75 (577.85)	16	1.250 (31.8)	23.50 (596.90)	21.250 (539.75)	16	1.125 (28.6)		0.375 (9.53)	0.866 (22.00)	0.866 (22.00)		0.750 (19.05)	0.750 (19.05)	31.625 (803.3)	1.250 (31.8)

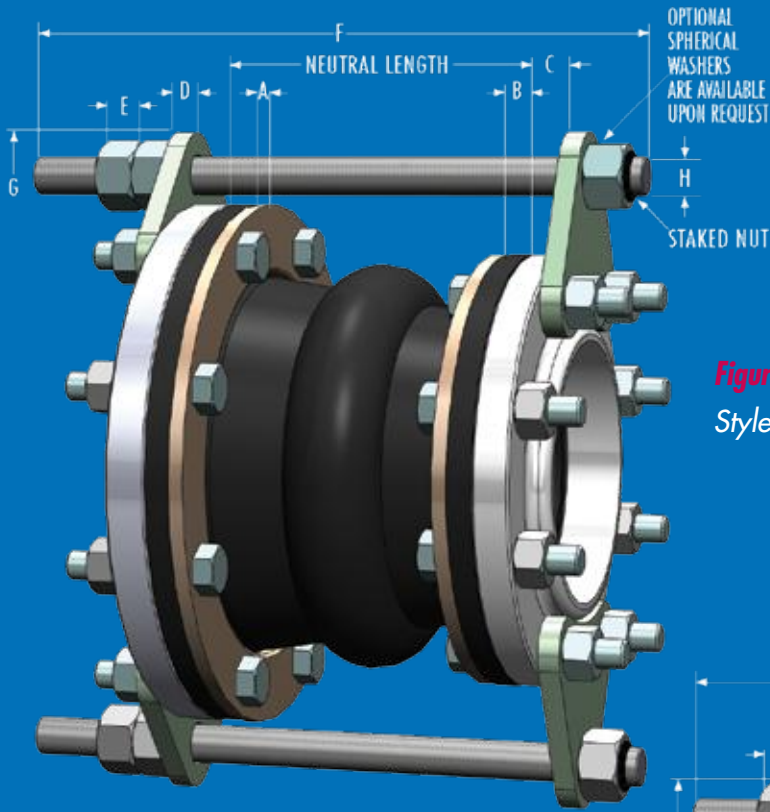
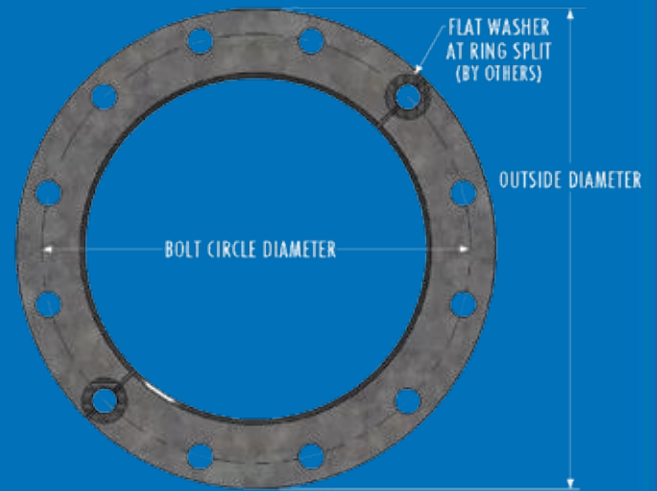
Metric Conversion Formula: Nominal I.D.: in. x 25 = mm; Dimensions/Thickness': in. x 25.4 = mm.

## Notes:

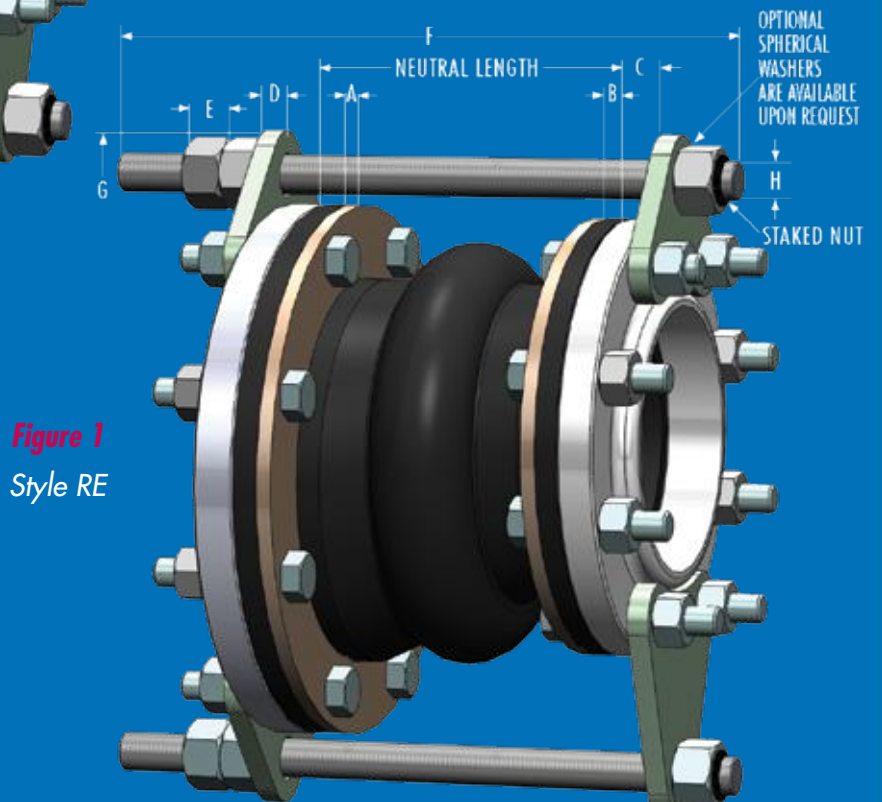
1. Limit/Control Rod length is determined by neutral length of rubber expansion joint, rated extension, control rod plate thickness, mating flange thickness and number of nuts. Consult PROCO for rod lengths.
2. Flange Dimensions shown are in accordance with ANSI B16.1 and ANSI B16.5 Class 125/150, AWWA C-207-07, Tbl 2 and 3 - Class D, Table 4 - Class E. Hole size shown is 1/8" larger than AWWA Standard.
3. Adjacent mating flange thickness is required to determine overall rod length and compression sleeve length (if required).
4. Plate thickness is based on a maximum width PROCO would use to design a Limit/Control Rod plate.
5. Flat Washers required at ring splits and are supplied by others.
6. Control rod plate O.D. installed dimension is based on a maximum O.D. Proco would supply.
7. Control rod diameter is based on a maximum diameter Proco would use to design a control rod.



- A** - Retaining Ring Thickness
- B** - Rubber Flange Thickness
- C** - Adjacent Mating Flange Thickness (By Others)
- D** - Control Unit Plate Thickness
- E** - Double Nut Thickness is determined by Control Rod Diameter
- F** - Control Rod Bolt Length is determined by A through E + OAL<sup>1</sup>
- G** - Control Rod Control Rod Plate O.D.
- H** - Maximum Rod Diameter



**Figure 1**  
Style RC



**Figure 1**  
Style RE

# Limit Rods

## Use of Control Units with Rubber Expansion Joints

### Definition

A control unit assembly is a system of two or more control rod units (limit rods) placed across an expansion joint from flange to flange to minimize possible damage caused by excessive motion of a pipeline. The control unit assemblies can be set at the maximum allowable expansion and/or contraction of the rubber expansion joint. When used in this manner, control units are an additional safety factor and can minimize possible damage to adjacent equipment.

Rubber expansion joints should be installed between two fixed anchor points in a piping system. The pipe system must be rigidly anchored on both sides of the expansion joint to control expansion or contraction of the line. Piping anchors must be capable of withstanding the line thrusts generated by internal pressure or wide temperature fluctuations.

When proper anchoring cannot be provided, **CONTROL UNITS ARE REQUIRED.** For un-anchored piping systems nuts shall be tightened snug against rod plate to prevent over extension due to pressure thrust created by an expansion joint. Refer to "Thrust Factor in Table 2, 3, and 4 note 5 in this manual.

### Figure 1

Known as a **LIMIT ROD**, this control unit configuration will allow an expansion joint to extend to a predetermined extension setting. Nuts shall be field set to no more than the maximum allowable extension movement of a rubber expansion joint (unless used in an un-anchored system). Refer to Table 2 in this manual for allowable movement capabilities. Spherical washers can also be furnished (upon request) to combat any "nut to plate" binding during offset. **Consult the systems engineer for proper nut settings prior to system operation.**

### Important Control Unit Considerations

The number of rods, control rod diameters and control rod plate thicknesses are important considerations when specifying control units for an application. As a minimum, specifying engineers or purchasers shall follow the guidelines as set forth in Appendix C of the Fluid Sealing Association's Technical Handbook, Seventh Edition. PROCO engineers its control unit assemblies to system requirements. Our designs incorporate an allowable stress of 65% of material yield for each rod and plate (rod and plate material to be specified by purchaser). Therefore, it is important to provide pressure and temperature ratings to PROCO when requesting control units for rubber expansion joints. It is also important to provide adjacent mating flange thickness or mating specifications to ensure correct rod lengths are provided.

## Installation Instructions for Limit Rods

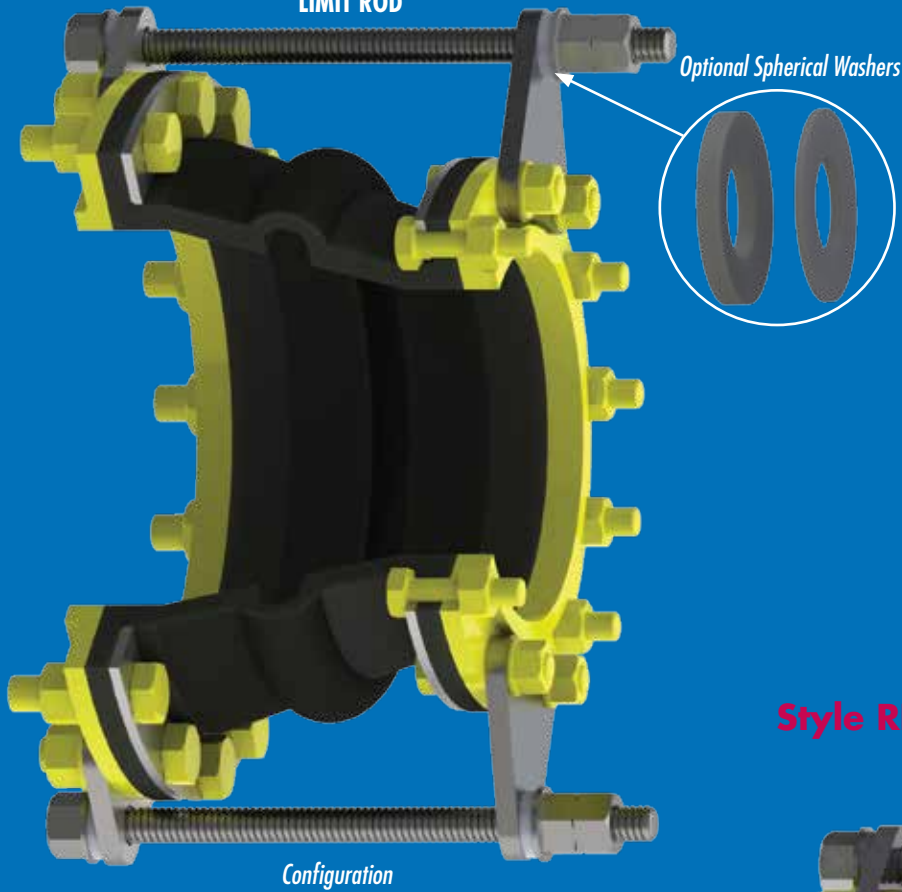
1. Assemble expansion joint between pipe flanges in its manufactured face-to-face length. Install the retaining rings furnished with the expansion joint.
2. Assemble control rod plates behind pipe flanges as shown. Flange bolts or all thread studs through the control rod plate must be longer to accommodate the plate thickness. Control rod plates should be equally spaced around the flange. Depending upon the size and pressure rating of the system, 2, 3, 4, or more control/limit rods may be required. Refer to Table 4 in this manual or to the Fluid Sealing Association's Technical Handbook, Seventh Edition, for control rod pressure ratings.
3. Insert control/limit rods through top plate holes. Steel flat washers are to be positioned at outer plate surface.
4. If a single nut per unit is furnished, position this nut so that there is a gap between the nut and the steel flat washer. This gap is equal to the joint's maximum extension (commencing with the nominal face-to-face length). To lock this nut in position, either "stake" the thread in two places or tack weld the nut to the rod. If two nuts are supplied, the nuts will create a "jamming" effect to prevent loosening. (Nuts should be snug against flat washer and control rod plate when piping system is un-anchored.)

*Note: Consult the manufacturer if there are any questions as to the rated compression and elongation. These two dimensions are critical in setting the nuts and sizing the compression pipe sleeve (if supplied).*

5. If there is a requirement for compression pipe sleeves, ordinary pipe may be used, sized in length to allow the joint to be compressed to its normal limit.
6. If there is a requirement for optional spherical washers, these washers are to be positioned at the inner and/or outer plate surface and backed up by movable double nuts.

## Style RC

**Figure 1**  
**LIMIT ROD**



## Style RE

**Figure 1**  
**LIMIT ROD**

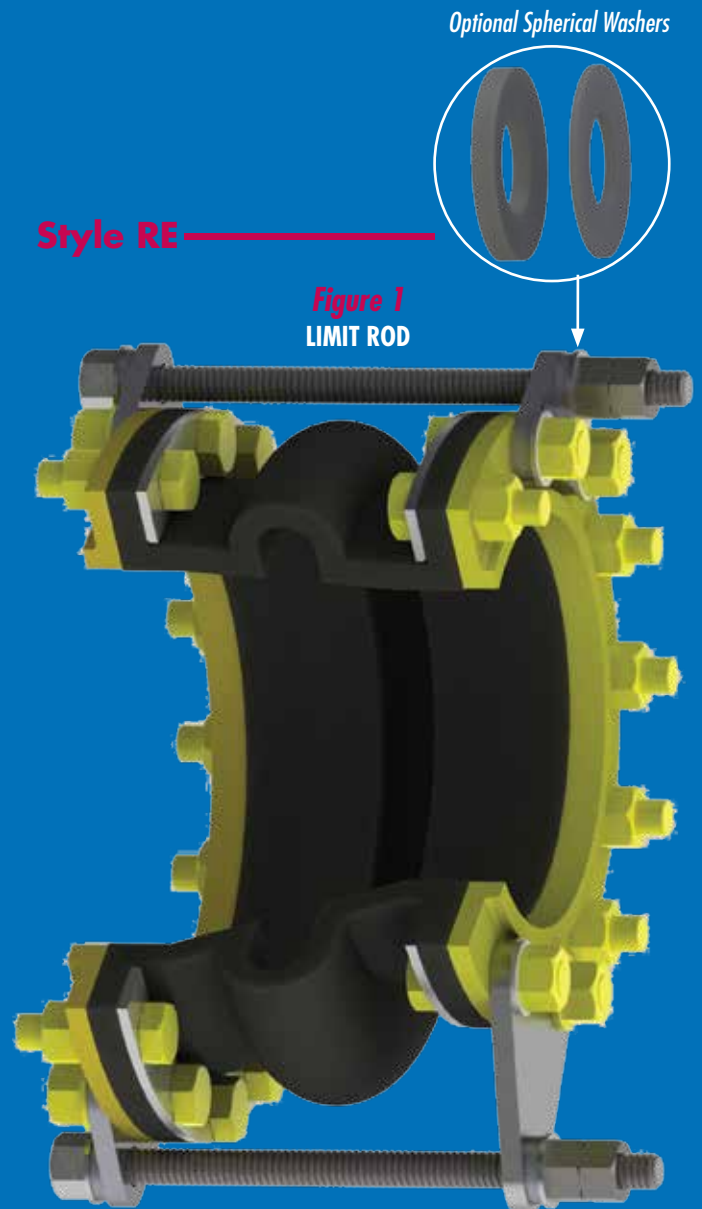


Table 6		Maximum Surge or Test Pressure of the Systems	
Nominal Pipe Size Expansion Joint I.D. (Small End) Inch / (mm)		Number of Limit Rods Recommended	
		2	4
2	(50)	661	•
2.5	(65)	529	•
3	(75)	441	•
4	(100)	311	622
5	(125)	235	470
6	(150)	186	371
8	(200)	163	326
10	(250)	163	325
12	(300)	160	320
14	(350)	112	223
16	(400)	113	227

Notes:  
 1. Pressures listed above do not relate to the actual design pressure of the expansion joint products, but are the maximum surge or pressure for a specific control rod nominal pipe size.  
 2. Four rod sets for concentric

# Installation Instructions for Non-Metallic Expansion Joints

## 1. Service Conditions:

Make sure the expansion joint rating for temperature, pressure, vacuum and movements match the system requirements. Contact the manufacturer for advice if the system requirements exceed those of the expansion joint selected. Check to make sure the elastomer selected is chemically compatible with the process fluid or gas.

## 2. Alignment:

Expansion joints are normally not designed to make up for piping misalignment errors. Piping should be lined up within 1/8". Misalignment reduces the rated movements of the expansion joint and can induce severe stress and reduce service life. Pipe guides should be installed to keep the pipe aligned and to prevent undue displacement.

## 3. Anchoring:

Solid anchoring is required wherever the pipeline changes direction and expansion joints should be located as close as possible to anchor points. If piping is not adequately anchored, control rods should be used. If anchors are not used, pressure thrust may cause excessive movement damaging the expansion joint.

## 4. Pipe Support:

Piping must be supported by hangers or anchors so expansion joints do not carry any pipe weight.

## 5. Mating Flanges:

Install the expansion joint against the mating pipe flanges and install bolts so that the bolt head and washer are against the retaining rings. If washers are not used, flange leakage can result — particularly at the split in the retaining rings. Flange-to-flange dimension of the expansion joint must match the breach opening. Make sure the mating flanges are clean and are a flat faced type or no more than 1/16" raised face type. Never install expansion joints that utilize split retaining rings next to wafer type check or butterfly valves. Serious damage can result to a rubber joint of this type unless installed against full face flanges.

## 6. Bolting Torque:

Table 5 shows the recommended torque ranges for non-metallic expansion joints with full-faced rubber flanges. Torque specifications are approximate. Tighten bolts in stages using cross-bolt tightening pattern. If the joint has integral fabric and rubber flanges, the bolts should be tight enough to make the rubber flange OD bulge between the retaining rings and the mating flange. After installation, the system should be pressurized and examined to confirm a proper seal. Torque bolts sufficiently to assure leak free operation at hydrostatic test pressure. *Note: Torque values are approximate due to mating flange surfaces, installation offsets, operating pressures and environmental conditions.*

Table 7 Size	Approximate Torque Values
1" THRU 2"	20 - 40 ft/lbs
2.5" THRU 5"	25 - 60 ft/lbs
6" THRU 12"	35 - 140 ft/lbs
14" THRU 18"	50 - 180 ft/lbs

## 7. Storage:

Ideal storage is in a warehouse with a relatively dry, cool location. Store flanges face down on a pallet or wooden platform. Do not store other heavy items on top of expansion joints. Ten year shelf life can be expected with ideal conditions. If storage must be outdoors, place on wooden platform and joints should not be in contact with the ground. Cover with a tarpaulin.

## 8. Large Joint Handling:

Do not lift with ropes or bars through the bolt holes. If lifting through the bore, use padding or a saddle to distribute the weight. Make sure cables or forklift tines do not contact the rubber. Do not let expansion joints sit vertically on the edges of the flanges for any period of time.

## 9. Additional Tips:

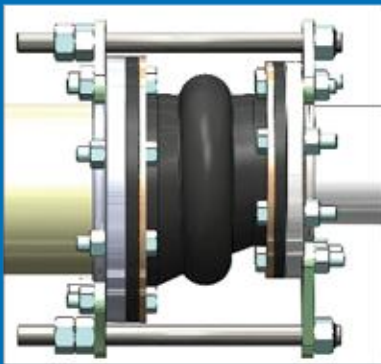
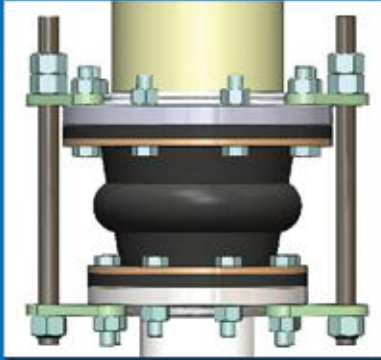
- Do not insulate over a non-metallic expansion joint.
- It is acceptable (but not necessary) to lubricate the expansion joint flanges with a thin film of graphite dispersed in glycerin or water to ease disassembly at a later time.
- Do not weld in the near vicinity of a non-metallic joint.
- If expansion joints are to be installed underground, or will be submerged in water, contact manufacturer for specific recommendations.
- If the expansion joint will be installed outdoors, make sure the cover material will withstand ozone, sunlight, etc.
- Check the tightness of lead-free flanges two or three weeks after installation and retighten if necessary.

*Warning: Expansion joints may operate in pipelines or equipment carrying fluids and/or gasses at elevated temperature and pressures and may transport hazardous materials. Precautions should be taken to protect personnel in the event of leakage or splash. Rubber joints should not be installed in areas where inspection is impossible. Make sure proper drainage is available in the event of leakage when operating personnel are not available.*

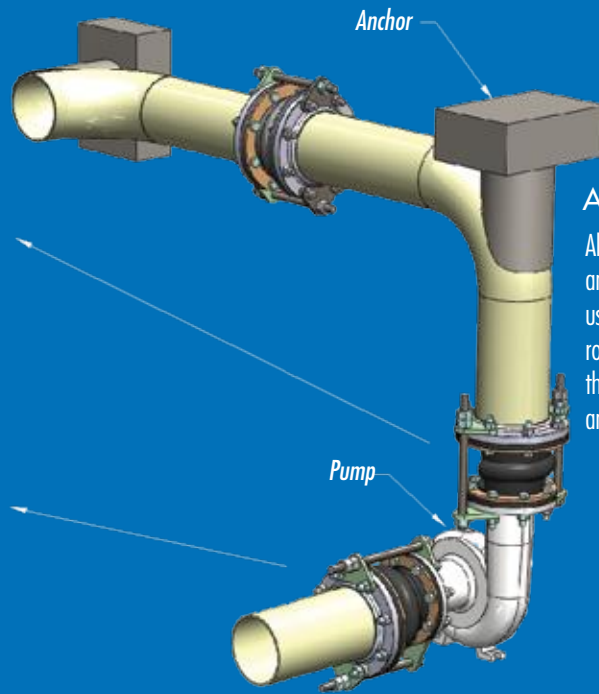
# Piping System Layout Examples

## Anchored System

Pump Discharge  
Concentric



Pump Inlet  
Eccentric

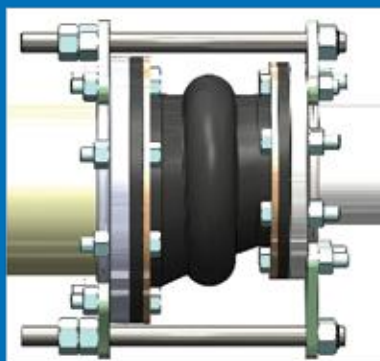
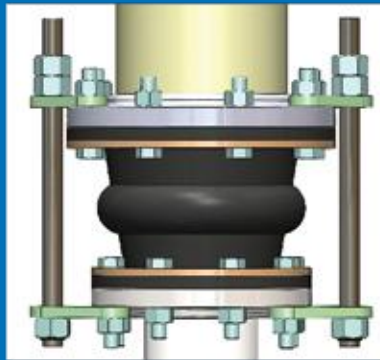


### Anchored System Note:

Although limit rods are not required in an anchored pipe system, you may want to consider using them. If an anchor were to fail, the limit rods would be capable of handling the pressure thrust of the system and lessen the likelihood of an expansion joint failure.

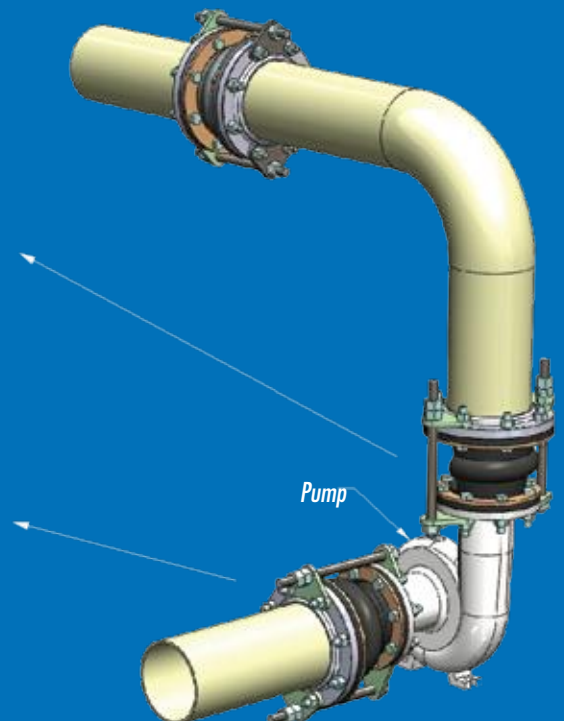
## Un-Anchored System

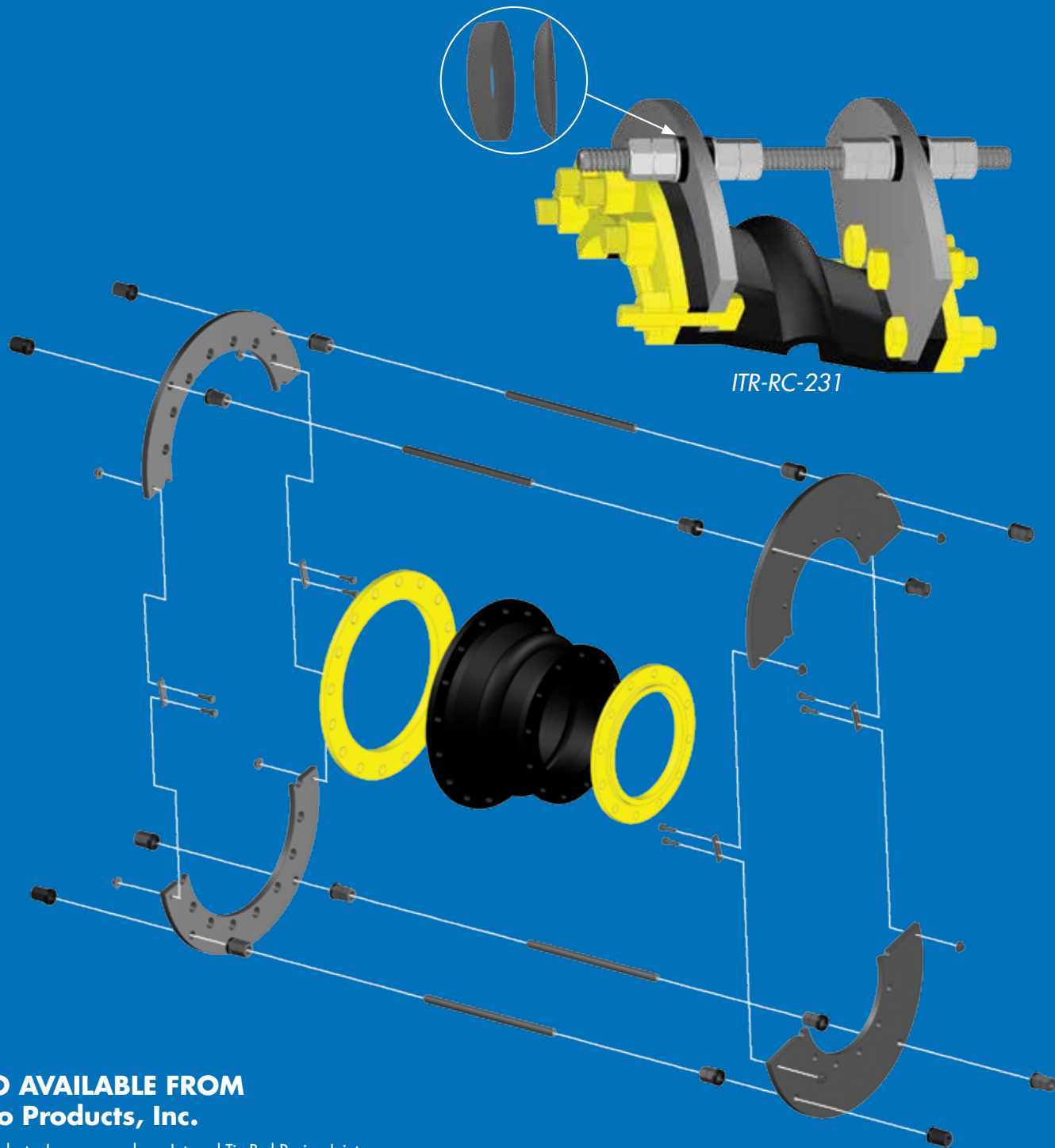
Pump Discharge  
Concentric



### Un-Anchored System Note:

Rod sets should be installed so that external nuts are snug against the plate at installation. Pressure thrust of the pipe system can cause expansion joint to over-elongate and reduce movement capabilities.





**ALSO AVAILABLE FROM  
Proco Products, Inc.**

Proco Products, Inc. can supply an Integral Tie Rod Design Joint when space prohibits use of typical rod designs.



*The Expansion Joint  
and  
Check Valve People*

Toll-Free Phone: (800) 344-3246

Facsimile: (209) 943-0242

2431 North Wigwam Dr. (95205)  
P.O. Box 590 • Stockton, CA  
95201-0590 • USA

**NATIONWIDE AND CANADA**



**REPRESENTED BY:**

**GOODYEAR**  
RUBBER PRODUCTS, INC.

**727-342-5088**

You can also email us at  
**GRP@goodyearrubberproducts.com**

# PROCO

The Expansion Joint and Check Valve People

## SERIES 231/ET

### PTFE Lined Rubber Expansion Joints



The PROCO Series 231/ET PTFE lined expansion joints are designed for tough demanding corrosive chemical applications, as found in: Chemical & Petrochemical Process Facilities and Highly Corrosive Industrial Piping & Pollution Control Systems. The greatest usage of the Series 231/ET is found in the Pulp and Paper Industry where the ability to resist corrosive attack at elevated temperature and pressure is unmatched by metallic, plastic or other competitive expansion joints. PROCO's Series 231 PTFE lined expansion joints can easily handle such pulp/paper applications as: White-Green-Black liquor, bleach plant chlorination and caustic extraction stages. Chemically resistant against the entire pH range, PROCO Series 231 PTFE expansion joints are designed to handle practically every chemical plant application. Installed next to mechanical equipment or between anchor points of a piping system, specify the PROCO 231/ET to: (1) Absorb Pipe Movements/ Stress, (2) Reduce System Noise, (3) Isolate Mechanical Vibrations, (4) Compensate Alignment/Offset, (5) Eliminate Electrolytic Action and Electrolysis, (6) Protect Against Start-Up/Surge Forces. Our history in the manufacture of expansion joints dates back to 1930. When you need an engineered rubber expansion joint solution to a piping problem, call PROCO.

**Series 231/ET.** The new and improved PROCO Series 231/ET will complement the existing PROCO Series 251/ET expansion joint. This new molded product has been completely re-engineered to provide improved strength, flexibility and movement capabilities. Manufactured utilizing tire cord industry technology, the Series 231/ET combines woven polyester tire cord into a fabric matrix and bonded with a EPDM elastomer that is reinforced with metal and bonded to a PTFE liner to create a product with greater operating performance. *Note: The PTFE liner extends to the bolt circle of the bottom of bolt holes.*

**Greater Movements with a Lower/Wider Arch Profile.** The movements for the PROCO Series 231/ET exceed the specification of the Fluid Sealing Association's, Rubber Expansion Joint Division Technical Handbook (7.3 Edition), Table VI. Due to a new and improved lower, wider profile arch, more axial compression and extension coupled with lateral and angular movements can be obtained without increasing the face-to-face requirements. For greater movements based on re-engineering and new product construction for highly corrosive piping installations, specify the PROCO Series 231/ET PTFE lined expansion joints.

**Chemical Service Capability at Minimal Cost.** Expensive, exotic metal expansion joint for low temperature service can be replaced with the PROCO Series 231/ET PTFE lined expansion joints. Engineered to operate up to 225 PSIG and 250°F, the PROCO Series 231/ET can be specified for a wide range of piping system requirements. Our standard stock is furnished with an exterior EPDM cover. Compared to metal, plastic or other rubber-backed competitive products, you will invest less and have access to in-stock availability with the high quality PROCO Series 231/ET.

**Specifications Met.** PROCO has assigned conservative pressure ratings to the Series 231/ET PTFE lined rubber expansion joints. The ratings, however, meet the requirements of the Fluid Sealing Association's, Rubber Expansion Joint Division Technical Handbook (7.3 Edition), Series C. The pressure ratings for the Series 231/ET PTFE lined rubber expansion joints have been fully tested and are based on a minimum 4 to 1 safety factor. For pressure protection with confidence, specify the PROCO Series 231/ET.

**Prevents Electrolysis and Electrolytic Action.** In Chemical applications when metallic expansion joints are used, they are generally of a metal dissimilar from the pipeline. This may create an electrolytic galvanic action that could be destructive to the connector equipment or piping system. The use of the rubber-backed PROCO 231/ET PTFE lined expansion joints prevents this potential hazard. Additionally, our 231/ET expansion joints are non-conductive and eliminate the metal-to-metal contact at the flange face thus stopping electrolysis.

**Absorbs Vibration • Noise • Shock.** The PROCO Series 231/ET PTFE lined rubber expansion joints are a replacement for "sound transmitting" metallic expansion joints. Sound loses energy traveling axially through an expansion joint. Water hammer, pumping impulses, water-borne noises and other forms of strain-stress-shock are cushioned and absorbed by the PTFE lined/rubber elastomer expansion joint, not related to piping. Install the Series 231/ET in a system to reduce vibration transmission when the piping section beyond the expansion joint is anchored or sufficiently rigid. For quiet, stress-free systems specify the PROCO Series 231/ET.

**Large Inventories Mean Same-Day Shipment.** We maintain the largest inventory of expansion joints in the world. Rubber, PTFE Lined, Plastic or Metal Hose — PROCO can ship the products you need when you need them! In fact, when it comes to expansion joints, if PROCO doesn't have them in stock ... nobody does!

**Information • Ordering • Pricing • Delivery.** Day or night, weekends and holidays ... the PROCO phones are monitored 24 hours around the clock. When you have a question, you can call us.

Toll-Free Phone ..... 800 / 344-3246 USA/CANADA

International Calls ..... 209 / 943-6088

Fax ..... 209 / 943-0242

Email ..... sales@procoproducts.com

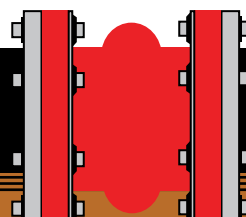
Website ..... www.procoproducts.com

Weekday office hours are 5:30 a.m. to 5:15 p.m. Pacific Time.

© PROCO PRODUCTS, INC.  
Rev. 01 3/16

#### Table 1: Available Styles • Design Descriptions • I.D. Sizes

#231/ET — Standard Single-Arch, Spool-Type Joint (See Table 2)	1"–36"
#251/ET — Standard Single-Arch, Spool-Type Joint	1"–48"



Protecting Piping and Equipment  
Systems from Stress/Motion

**GOODYEAR**  
RUBBER PRODUCTS, INC.

727-342-5088

You can also email us at  
[GRP@goodyearrubberproducts.com](mailto:GRP@goodyearrubberproducts.com)

# PTFE Lined Rubber Expansion Joints

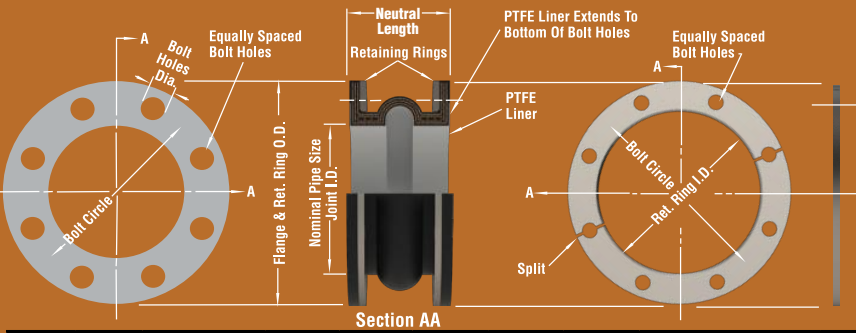


Figure 1: Detail of Style 231/ET

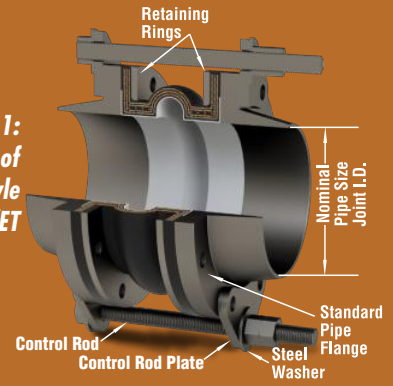


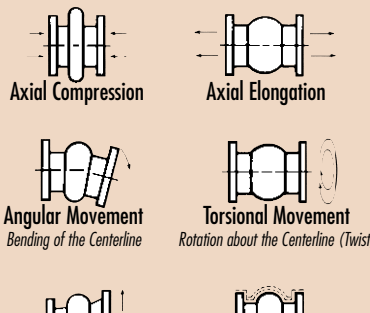
Table 2: Sizes • Movements • Pressures • Weights • Drilling

EXPANSION JOINT SIZE Nom. I.D. x Inch / (mm) <sup>1</sup>		NEUTRAL LENGTH Inch / (mm)		231/ET Movement Capability: From Neutral Position					Operating Conditions <sup>5</sup>			Weights in lbs / (kgs) <sup>6</sup>			Flange Dimensions and Drilling <sup>8</sup>							
				Axial Compression Inch / (mm)	Axial Extension Inch / (mm)	Lateral Deflection Inch / (mm)	Angular Deflection <sup>2</sup> Degrees	Torsional Rotation <sup>3</sup> Degrees	Thrust Factor <sup>4</sup> In 2 / (cm 2)	Positive PSIG / (Bar)	Vacuum Inches of Hg / (mm of Hg)	Joint Assembly	Retaining Ring Set	Control Unit <sup>7</sup> Assembly	O.D. of Exp. Joint / Ring Inch / (mm)	Bolt Circle Inch / (mm)	Number of Holes	Size of Holes Inch / (mm)				
1.5	(40)	6	(150)	1.25 (32)	0.625 (16)	0.625 (16)	28.0°	1°	7.03 (45)	225 (15.5)	30 (762)	1.5 (0.7)	2.5 (1.1)	2.3 (1.0)	5.0 (127.0)	3.88 (98.6)	4	0.625 (15.88)				
2	(50)						25.0°		12.56 (81)	225 (15.5)	30 (762)	2.0 (0.9)	4.0 (1.8)	2.8 (1.3)	6.0 (152.4)	4.75 (120.65)	4	0.750 (19.05)				
2.5	(65)						20.2°		15.82 (102)	225 (15.5)	30 (762)	2.5 (1.2)	4.5 (2.0)	2.8 (1.3)	7.0 (177.8)	5.50 (139.7)	4	0.750 (19.05)				
3	(80)						18.0°		19.63 (127)	225 (15.5)	30 (762)	3.0 (1.4)	5.5 (2.5)	2.8 (1.3)	7.5 (190.5)	6.00 (152.4)	4	0.750 (19.05)				
4	(100)						14.2°		28.27 (182)	225 (15.5)	30 (762)	4.0 (1.8)	8.0 (3.6)	2.8 (1.3)	9.0 (228.6)	7.50 (190.5)	8	0.750 (19.05)				
5	(125)						13.0°		39.26 (253)	225 (15.5)	30 (762)	5.0 (2.3)	8.5 (3.9)	4.0 (1.8)	10.0 (254.0)	8.50 (215.9)	8	0.875 (22.23)				
6	(150)						12.2°		50.27 (324)	225 (15.5)	30 (762)	7.0 (3.2)	9.5 (4.3)	4.0 (1.8)	11.0 (279.4)	9.50 (241.3)	8	0.875 (22.23)				
8	(200)						12.0°		78.54 (507)	210 (14.5)	30 (762)	11.0 (5.0)	14.5 (6.6)	8.0 (3.6)	13.5 (342.9)	11.75 (298.4)	8	0.875 (22.23)				
10	(250)	8	(200)	2.0 (50)	1.0 (25)	1.0 (25)	11.9°	113.1 (730)	210 (14.5)	30 (762)	19.0 (8.6)	17.0 (7.7)	10.0 (4.5)	16.0 (406.4)	14.25 (362.0)	12	1.000 (25.40)					
12	(300)						11.3°	153.94 (993)	210 (14.5)	30 (762)	29.0 (13.2)	24.5 (11.0)	10.0 (4.5)	19.0 (482.6)	17.00 (431.8)	12	1.000 (25.40)					
14	(350)						11.5°	201.06 (1297)	150 (10.0)	30 (762)	38.0 (17.2)	27.0 (12.3)	12.0 (5.4)	21.0 (533.4)	18.75 (476.3)	12	1.125 (28.58)					
16	(400)						10.1°	254.47 (1642)	150 (10.0)	30 (762)	44.0 (20.0)	33.5 (15.2)	15.0 (6.8)	23.5 (596.9)	21.25 (539.8)	16	1.125 (28.58)					
18	(450)						8.9°	314.16 (2027)	150 (10.0)	30 (762)	49.0 (22.2)	34.0 (15.5)	16.5 (7.2)	25.0 (635.0)	22.75 (577.9)	16	1.250 (31.75)					
20	(500)						8.1°	380.13 (2452)	150 (10.0)	30 (762)	54.0 (24.5)	38.0 (17.3)	16.5 (7.2)	27.5 (698.5)	25.00 (635.0)	20	1.250 (31.75)					
24	(600)						10	(250)	3.0 (75)	1.5 (38)	1.5 (38)	9.0°	530.93 (3425)	110 (7.5)	28 (711)	60.0 (27.2)	48.0 (21.8)	20.0 (9.0)	32.0 (812.8)	29.50 (749.3)	20	1.375 (34.93)
30	(750)											7.5°	838.65 (5410)	100 (7.0)	28 (711)	88.0 (44.0)	63.0 (28.6)	29.5 (13.3)	38.8 (984.3)	36.00 (914.4)	28	1.375 (34.93)
36	(900)	6.7°	1169.16 (7543)	100 (7.0)	28 (711)	112.0 (50.8)						76.0 (34.5)	43.0 (19.5)	46.0 (1168.4)	42.75 (1085.9)	32	1.625 (41.28)					

Notes:

1. PTFE liner extends to bottom of bolt holes.
2. The degree of angular movement is based on the maximum rated extension.
3. Torsional movement is expressed when the expansion joint is a neutral length.
4. To determine "end thrust", multiply thrust factor by operating pressure of system.
5. Pressure rating is based on 194°F operating temperature. At higher temperature the pressure rating is slightly reduced.
6. Weights are approximate.
7. Control unit weight consists of one rod, four washers, three nuts and two control rod plates. Multiply number of control units needed for application (as specified in the Fluid Sealing Association Technical Handbook) to determine correct weights.
8. Dimensions shown are in accordance with 125/150# standards of ANSI B-16.1, B-16.24, B-16.5; AWWA C-207 Table 1 and 2 Class D.

Proco™ Series 231/ET products are designed to absorb different movements concurrently.



Distributed By:

Warning: Expansion joints may operate in pipelines or equipment carrying fluids and/or gases at elevated temperatures and pressures. Normal precautions should be taken to make sure these parts are installed correctly and inspected regularly. Precautions should be taken to protect personnel in the event of leakage or splash. Note: Piping must be properly aligned and anchored to prevent damage to an expansion joint. Movement must not exceed specified ratings and control



2431 North Wigwam Dr. (95205)  
P.O. Box 590 • Stockton, CA  
95201-0590 • USA

# PROCO

*The Expansion Joint and Check Valve People*



**RUBBER EXPANSION JOINT STYLE 233-L & 234-L**

**GOODYEAR**  
RUBBER PRODUCTS, INC.

☎ 727-342-5088

You can also email us at  
[GRP@goodyearrubberproducts.com](mailto:GRP@goodyearrubberproducts.com)

# Proco Style 233-L & 234-L Rubber Joints

**Proco Style 233-L** Rubber Expansion Joints are designed for piping systems that experience large lateral offsets due to settlement. The Style 233-L is a low profile triple arch design with a built-in reinforcing ring at the top of the arch to provide extra stability for lateral movements up to 4”.

**Proco Style FA233-L** Rubber Expansion Joints are designed for piping systems carrying heavy solids that experience large lateral offsets due to settlement. The Style FA233-L is a low profile triple filled arch design with a built-in reinforcing ring at the top of the arch to provide extra stability for lateral movements up to 2”.

**Proco Style 234-L** Rubber Expansion Joints are designed for piping systems that experience large lateral offsets due to settlement. The Style 234-L is a low profile quadruple arch design with a built-in reinforcing ring at the top of the arch to provide extra stability for lateral movements up to 8”.

**Proco Style FA234-L** Rubber Expansion Joints are designed for piping systems carrying heavy solids that experience large lateral offsets due to settlement. The Style FA234-L is a low profile quadruple filled arch design with a built-in reinforcing ring at the top of the arch to provide extra stability for lateral movements up to 4”.

## Features and Benefits:

### Absorbs Directional Movement

Thermal movements appear in any rigid pipe system due to temperature changes. The Style 233-L and 234-L low profile arch allows for axial compression or axial extension, lateral deflection as well as angular and torsional movements. (Note: Rated movements in this publication are based on one plane movements. Multiple movement conditions are based on a multiple movement calculation. Contact Proco for information when designing multiple pipe movements.)

### Absorbs Vibration, Noise and Shock

The Style 233-L and 234-L expansion joints are manufactured with the integral rubber flange joining the body at a true 90° angle. This ensures the product will install snug against the mating pipe flange free of voids creating less turbulence in the pipe system.

### Compensates for Misalignment

The Style 233-L and 234-L expansion joints are designed for large lateral movements due to long term settlement. (Although rubber expansion joints can be made with permanent offsets, it is suggested that piping misalignments be limited to no more than 1/8” per the Fluid Sealing Association Piping Expansion Technical Handbook [www.fluidsealing.com](http://www.fluidsealing.com).)

### Wide Service Range and Less Weight

Engineered to operate up to 145 PSIG (nominal size dependent) or up to 250°F (elastomer dependent), the Series 233-L and 234-L can be specified for a wide range of piping system requirements. The Series 233-L and 234-L rubber expansion joints are constructed in various elastomers with rubber impregnated polyester tire cord and a reinforcing ring at the top of the arch to provide stability in large lateral offset conditions.

### Material Identification

All 233-L and 234-L expansion joints are strip branded with cure dates and elastomer designations.

EE-NSF/61 - ANSI/NSF Standard 61 standards were developed by the National Sanitation Foundation (NSF), and the American National Standards Institute (ANSI) and relates to water treatment which establishes stringent requirements for the control of equipment that comes in contact with either potable water or products that support the production of potable water

### Large Inventory

Proco Products, Inc. maintains one of the largest inventories of rubber expansion joints in the world. Please contact us for price and availability.



**Table 1: Available Materials • Temperatures**

For Specific Chemical Compatibilities, See: <b>PROCO “Chemical To Elastomer Guide”</b>					
Material Code	Cover <sup>1,2</sup> Elastomer	Tube Elastomer	Maximum Operating Temp. °F (°C)	Branding Label Color	F.S.A. Material Class
<b>BB</b>	Chlorobutyl	Chlorobutyl	250° (121°)	Black	STD. III
<b>EE</b>	EPDM	EPDM	250° (121°)	Red	STD. III
<b>EE-NSF/61<sup>4</sup></b>	EPDM	EPDM	250° (121°)	Red	STD. III
<b>EQ</b>	EPDM	FDA-EPDM	250° (121°)	Red <sup>2</sup>	STD. II
<b>NH</b>	Neoprene	CSM	212° (100°)	Green	STD. II
<b>NN</b>	Neoprene	Neoprene	225° (107°)	Blue	STD. II
<b>NF</b>	Neoprene	FDA-Neoprene	225° (107°)	Blue <sup>2</sup>	STD. II
<b>NP</b>	Neoprene	Nitrile	212° (100°)	Yellow	STD. II
<b>NR</b>	Neoprene	Natural Rubber	180° (82°)	White	STD. I

**Protecting Piping and Equipment Systems from Stress/Motion**

Information subject to change without notice.

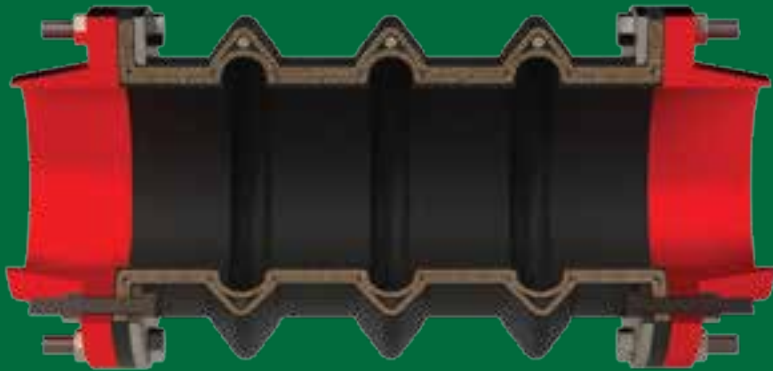
Notes: All Products are reinforced with Polyester Tire Cord  
1. For more information on our products, visit [www.proco.com](http://www.proco.com)  
2. For more information on our products, visit [www.proco.com](http://www.proco.com)

**GOODYEAR**  
RUBBER PRODUCTS, INC.

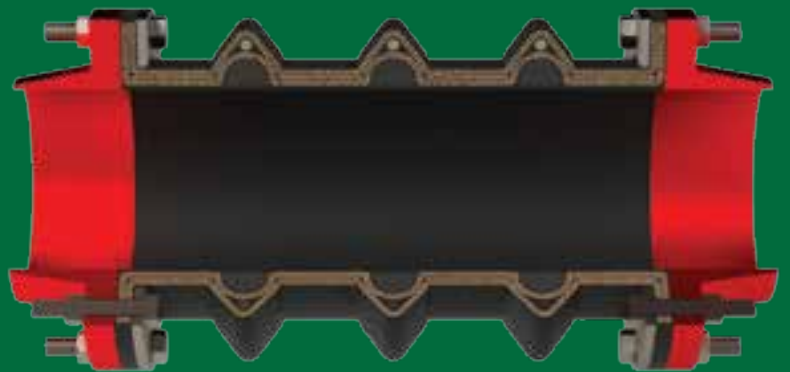
727-342-5088

You can also email us at  
[GRP@goodyearrubberproducts.com](mailto:GRP@goodyearrubberproducts.com)

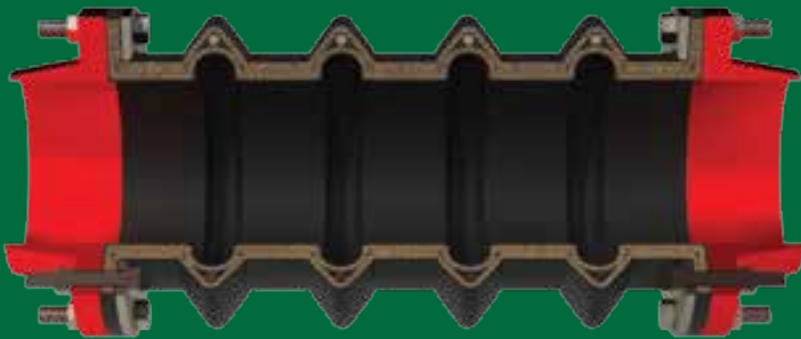
**Style 233-L**



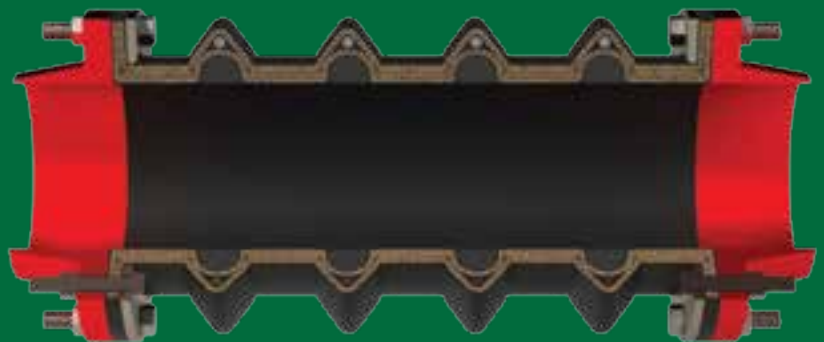
**Style FA233-L**



**Style 234-L**



**Style FA234-L**



# Style 233-L Performance Data

**Table 2: Sizes • Movements • Design Pressures • Weights**

Expansion Joint Size Nom. I.D. Inch / (mm)	Neutral Length Inch / (mm)	233-L Movement Capability: <sup>1</sup> From Neutral Position (Non-Concurrent)					Operating Conditions <sup>2</sup>			Weights lbs / (kgs) <sup>3</sup>	
		Axial Compression Inch / (mm)	Axial Extension Inch / (mm)	Lateral Deflection Inch / (mm)	Angular Deflection <sup>4</sup> (Degrees)	Torsional Rotation <sup>5</sup> (Degrees)	Thrust Factor <sup>6</sup> In <sup>2</sup> / (cm <sup>2</sup> )	Positive PSIG (Bar)	Vacuum Inches of Hg / (mm of Hg) <sup>7</sup>	Expansion Joint	Retaining Ring Set
<b>2</b> (50)	14 (356)	2.36 (60)	1.57 (40)	4 (100)	57.6°	2°	10.03 (64)	145 (10)	26 (660)	5.0 (2.3)	4.0 (1.8)
<b>2.5</b> (65)	14 (356)	2.36 (60)	1.57 (40)	4 (100)	51.6°	2°	13.04 (84)	145 (10)	26 (660)	6.0 (2.8)	4.5 (2.0)
<b>3</b> (80)	14 (356)	2.36 (60)	1.57 (40)	4 (100)	46.4°	2°	16.44 (106)	145 (10)	26 (660)	9.0 (4.1)	5.5 (2.5)
<b>4</b> (100)	14 (356)	2.36 (60)	1.57 (40)	4 (100)	38.2°	2°	24.41 (157)	145 (10)	26 (660)	12.0 (5.3)	8.0 (3.6)
<b>5</b> (125)	14 (356)	2.36 (60)	1.57 (40)	4 (100)	32.2°	2°	33.95 (219)	145 (10)	26 (660)	14.0 (6.5)	8.5 (3.9)
<b>6</b> (150)	20 (508)	2.36 (60)	1.57 (40)	4 (100)	27.7°	2°	45.06 (290)	145 (10)	26 (660)	26.0 (11.6)	9.5 (4.3)
<b>8</b> (200)	20 (508)	2.36 (60)	1.57 (40)	4 (100)	21.5°	2°	72.00 (469)	145 (10)	26 (660)	34.0 (15.2)	14.5 (6.6)
<b>10</b> (250)	20 (508)	2.36 (60)	1.57 (40)	4 (100)	17.5°	2°	105.22 (678)	145 (10)	26 (660)	42.0 (19.6)	17.0 (7.7)
<b>12</b> (300)	22 (559)	2.36 (60)	1.57 (40)	4 (100)	14.7°	2°	153.25 (988)	145 (10)	26 (660)	56.0 (25.4)	24.5 (33.5)
<b>14</b> (350)	22 (559)	2.75 (70)	1.97 (50)	4 (100)	15.7°	2°	200.27 (1292)	145 (10)	26 (660)	69.0 (31.2)	27.0 (12.2)
<b>16</b> (400)	22 (559)	2.75 (70)	1.97 (50)	4 (100)	13.8°	2°	253.58 (1636)	145 (10)	26 (660)	82.0 (37.1)	33.5 (15.2)
<b>18</b> (450)	22 (559)	2.75 (70)	1.97 (50)	4 (100)	12.3°	2°	313.17 (2020)	145 (10)	26 (660)	90.0 (40.8)	34.0 (15.4)
<b>20</b> (500)	22 (559)	2.75 (70)	1.97 (50)	4 (100)	11.1°	2°	379.05 (2445)	145 (10)	26 (660)	127.0 (52.9)	38.0 (17.2)
<b>24</b> (600)	22 (559)	2.75 (70)	1.97 (50)	4 (100)	9.3°	2°	562.25 (3627)	109 (7.5)	26 (660)	150.0 (67.7)	48.0 (21.8)
<b>28</b> (700)	26 (660)	2.75 (70)	1.97 (50)	4 (100)	8.0°	2°	742.93 (4793)	109 (7.5)	26 (660)	217.0 (98.3)	55.0 (24.9)

See Notes Page 4

**Table 2: Sizes • Movements • Design Pressures • Weights**

Expansion Joint Size Nom. I.D. Inch / (mm)	Neutral Length Inch / (mm)	233-L Movement Capability: <sup>1</sup> From Neutral Position (Non-Concurrent)					Operating Conditions <sup>2</sup>			Weights lbs / (kgs) <sup>3</sup>	
		Axial Compression Inch / (mm)	Axial Extension Inch / (mm)	Lateral Deflection <sup>4</sup> Inch / (mm)	Angular Deflection (Degrees)	Torsional Rotation <sup>5</sup> (Degrees)	Thrust Factor <sup>6</sup> In <sup>2</sup> / (cm <sup>2</sup> )	Positive PSIG (Bar)	Vacuum Inches of Hg / (mm of Hg) <sup>7</sup>	Expansion Joint	Retaining Ring Set
<b>30</b> (750)	<b>26</b> (660)	<b>2.75</b> (70)	<b>1.97</b> (50)	<b>4</b> (100)	<b>7.5°</b>	<b>2°</b>	<b>842.69</b> (5436)	<b>73</b> (5)	<b>26</b> (660)	<b>232.0</b> (105.4)	<b>63.0</b> (28.6)
<b>36</b> (900)	<b>26</b> (660)	<b>2.75</b> (70)	<b>1.97</b> (50)	<b>4</b> (100)	<b>6.2°</b>	<b>2°</b>	<b>1179.68</b> (7610)	<b>73</b> (5)	<b>26</b> (660)	<b>287.0</b> (130.0)	<b>76.0</b> (34.5)
<b>42</b> (1050)	<b>28</b> (711)	<b>2.75</b> (70)	<b>1.97</b> (50)	<b>4</b> (100)	<b>5.4°</b>	<b>2°</b>	<b>1573.22</b> (10149)	<b>73</b> (5)	<b>26</b> (660)	<b>369.0</b> (179.8)	<b>100.0</b> (45.4)
<b>48</b> (1200)	<b>28</b> (711)	<b>2.75</b> (70)	<b>1.97</b> (50)	<b>4</b> (100)	<b>4.7°</b>	<b>2°</b>	<b>2023.31</b> (13053)	<b>73</b> (5)	<b>26</b> (660)	<b>428.0</b> (193.9)	<b>132.0</b> (59.9)
<b>54</b> (1350)	<b>28</b> (711)	<b>2.75</b> (70)	<b>1.97</b> (50)	<b>4</b> (100)	<b>4.2°</b>	<b>2°</b>	<b>2460.24</b> (15872)	<b>73</b> (5)	<b>26</b> (660)	<b>548.0</b> (248.5)	<b>150.0</b> (68.0)
<b>60</b> (1500)	<b>30</b> (762)	<b>2.75</b> (70)	<b>1.97</b> (50)	<b>4</b> (100)	<b>3.8°</b>	<b>2°</b>	<b>3016.00</b> (19458)	<b>73</b> (5)	<b>26</b> (660)	<b>667.0</b> (302.7)	<b>200.0</b> (90.7)

NOTES:

- Concurrent Movements - Concurrent movements are developed when two or more movements in a pipe system occur at the same time. If multiple movements exceed single arch design there may be a need for additional arches.  
To perform calculation for concurrent movement when a pipe system design has more than one movement, please use the following formula:  

$$\frac{\text{Actual Axial Compression} + \text{Actual Axial Extension} + \text{Actual Lateral (X)} + \text{Actual Lateral (Y)}}{\text{Rated Axial Compression} + \text{Rated Axial Extension} + \text{Rated Lateral (X)} + \text{Rated Lateral (Y)}} = / < 1$$
 Calculation must be equal to or less than 1 for expansion joint to operate within concurrent movement capability.
- Pressure rating is based on 170° F operating temperature with a 4:1 safety factor. At higher temperatures, the pressure rating is reduced slightly. Hydrostatic testing at 1.5 times rated maximum catalog pressure or design working pressure of pipe system for 10 minutes is available upon request.
- Weights are approximate.
- The degree of angular movement is based on the maximum rated extension.
- Torsional movement is expressed when the expansion joint is at neutral length.
- Calculation of Thrust (Thrust Factor). When expansion joints are installed in the pipeline, the static portion of the thrust is calculated as a product of the area of the I.D. of the arch of the expansion joint times the maximum pressure (design, test or surge) that will occur in the line. The result is a force expressed in pounds.  
Take Design, surge or test pressure X thrust factor to calculate end thrust.

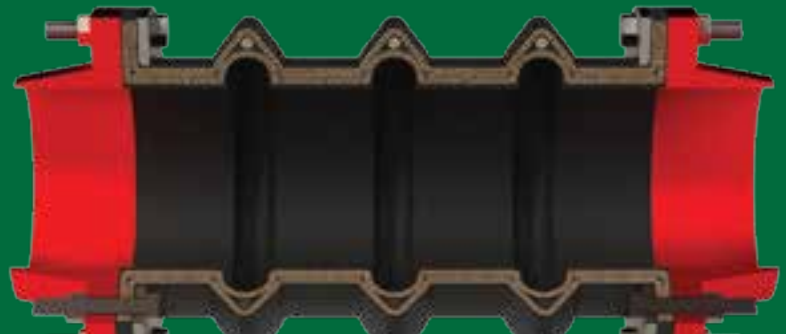
“Effective Area”

Thrust Factor=

$$T = \frac{\pi}{4} (D)^2 (P)$$

T= Thrust  
P= PSI (Design, Test or Surge)  
D= Arch I.D.

- Parts listed at 26” Hg / 660 mm Hg vacuum have a design rating of 30” Hg / 762 mm Hg (full vacuum). Vacuum rating is based on neutral installed length without external load.



# Style FA233-L Performance Data

**Table 3: Sizes • Movements • Design Pressures • Weights**

Expansion Joint Size Nom. I.D. Inch / (mm)	Neutral Length Inch / (mm)	FA233-L Movement Capability: <sup>1</sup> From Neutral Position (Non-Concurrent)					Operating Conditions <sup>2</sup>			Weights lbs / (kgs) <sup>3</sup>	
		Axial Compression Inch / (mm)	Axial Extension Inch / (mm)	Lateral Deflection Inch / (mm)	Angular Deflection <sup>4</sup> (Degrees)	Torsional Rotation <sup>5</sup> (Degrees)	Thrust Factor <sup>6</sup> In <sup>2</sup> / (cm <sup>2</sup> )	Positive PSIG (Bar)	Vacuum Inches of Hg / (mm of Hg) <sup>7</sup>	Expansion Joint	Retaining Ring Set
<b>2</b> (50)	14 (356)	1.18 (30)	.78 (20)	2 (50)	28.8°	1°	3.14 (20)	145 (10)	26 (660)	6.0 (2.9)	4.0 (1.8)
<b>2.5</b> (65)	14 (356)	1.18 (30)	.78 (20)	2 (50)	25.8°	1°	4.91 (31)	145 (10)	26 (660)	8.0 (3.5)	4.5 (2.0)
<b>3</b> (80)	14 (356)	1.18 (30)	.78 (20)	2 (50)	23.2°	1°	7.07 (45)	145 (10)	26 (660)	11.0 (5.1)	5.5 (2.5)
<b>4</b> (100)	14 (356)	1.18 (30)	.78 (20)	2 (50)	19.1°	1°	12.57 (81)	145 (10)	26 (660)	15.0 (6.6)	8.0 (3.6)
<b>5</b> (125)	14 (356)	1.18 (30)	.78 (20)	2 (50)	16.1°	1°	19.64 (126)	145 (10)	26 (660)	18.0 (8.1)	8.5 (3.9)
<b>6</b> (150)	20 (508)	1.18 (30)	.78 (20)	2 (50)	13.8°	1°	28.27 (182)	145 (10)	26 (660)	33.0 (14.5)	9.5 (4.3)
<b>8</b> (200)	20 (508)	1.18 (30)	.78 (20)	2 (50)	10.8°	1°	50.27 (324)	145 (10)	26 (660)	43.0 (19.0)	14.5 (6.6)
<b>10</b> (250)	20 (508)	1.18 (30)	.78 (20)	2 (50)	8.8°	1°	78.54 (506)	145 (10)	26 (660)	53.0 (24.5)	17.0 (7.7)
<b>12</b> (300)	22 (559)	1.18 (30)	.78 (20)	2 (50)	7.3°	1°	113.10 (729)	145 (10)	26 (660)	70.0 (31.8)	24.5 (11.1)
<b>14</b> (350)	22 (559)	1.38 (35)	1.0 (25)	2 (50)	7.8°	1°	153.94 (993)	145 (10)	26 (660)	86.0 (39.0)	27.0 (12.2)
<b>16</b> (400)	22 (559)	1.38 (35)	1.0 (25)	2 (50)	6.9°	1°	201.06 (1297)	145 (10)	26 (660)	103.0 (46.4)	33.5 (15.4)
<b>18</b> (450)	22 (559)	1.38 (35)	1.0 (25)	2 (50)	6.1°	1°	254.47 (1641)	145 (10)	26 (660)	113.0 (51.0)	34.0 (15.4)
<b>20</b> (500)	22 (559)	1.38 (35)	1.0 (25)	2 (50)	5.6°	1°	314.16 (2026)	145 (10)	26 (660)	159.0 (65.9)	38.0 (17.2)
<b>24</b> (600)	22 (559)	1.38 (35)	1.0 (25)	2 (50)	4.6°	1°	452.39 (2918)	109 (7.5)	26 (660)	188.0 (84.6)	48.0 (21.8)
<b>28</b> (700)	26 (660)	1.38 (35)	1.0 (25)	2 (50)	4.0°	1°	615.75 (3972)	109 (7.5)	26 (660)	271.0 (122.9)	55.0 (24.9)

See Notes Page 4

**Table 3: Sizes • Movements • Design Pressures • Weights**

Expansion Joint Size Nom. I.D. Inch / (mm)	Neutral Length Inch / (mm)	FA233-L Movement Capability: <sup>1</sup> From Neutral Position (Non-Concurrent)					Operating Conditions <sup>2</sup>			Weights lbs / (kgs) <sup>3</sup>	
		Axial Compression Inch / (mm)	Axial Extension Inch / (mm)	Lateral Deflection Inch / (mm)	Angular Deflection <sup>4</sup> (Degrees)	Torsional Rotation <sup>5</sup> (Degrees)	Thrust Factor <sup>6</sup> In <sup>2</sup> / (cm <sup>2</sup> )	Positive PSIG (Bar)	Vacuum Inches of Hg / (mm of Hg) <sup>7</sup>	Expansion Joint	Retaining Ring Set
<b>30</b> (750)	<b>26</b> (660)	<b>1.38</b> (35)	<b>1.0</b> (25)	<b>2</b> (50)	<b>3.8°</b>	<b>1°</b>	<b>706.86</b> (4560)	<b>73</b> (5)	<b>26</b> (660)	<b>290.0</b> (131.8)	<b>63.0</b> (28.6)
<b>36</b> (900)	<b>26</b> (660)	<b>1.38</b> (35)	<b>1.0</b> (25)	<b>2</b> (50)	<b>3.1°</b>	<b>1°</b>	<b>1017.88</b> (6566)	<b>73</b> (5)	<b>26</b> (660)	<b>359.0</b> (162.5)	<b>76.0</b> (34.5)
<b>42</b> (1050)	<b>28</b> (711)	<b>1.38</b> (35)	<b>1.0</b> (25)	<b>2</b> (50)	<b>2.7°</b>	<b>1°</b>	<b>1385.44</b> (8938)	<b>73</b> (5)	<b>26</b> (660)	<b>495.0</b> (224.8)	<b>100.0</b> (45.4)
<b>48</b> (1200)	<b>28</b> (711)	<b>1.38</b> (35)	<b>1.0</b> (25)	<b>2</b> (50)	<b>2.4°</b>	<b>1°</b>	<b>1809.56</b> (11674)	<b>73</b> (5)	<b>26</b> (660)	<b>535.0</b> (242.4)	<b>132.0</b> (59.9)
<b>54</b> (1350)	<b>28</b> (711)	<b>1.38</b> (35)	<b>1.0</b> (25)	<b>2</b> (50)	<b>2.1°</b>	<b>1°</b>	<b>2290.22</b> (14775)	<b>73</b> (5)	<b>26</b> (660)	<b>685.0</b> (310.6)	<b>150.0</b> (68.0)
<b>60</b> (1500)	<b>30</b> (762)	<b>1.38</b> (35)	<b>1.0</b> (25)	<b>2</b> (50)	<b>1.9°</b>	<b>1°</b>	<b>2827.43</b> (18241)	<b>73</b> (5)	<b>26</b> (660)	<b>833.0</b> (378.4)	<b>200.0</b> (90.7)

NOTES:

- Concurrent Movements - Concurrent movements are developed when two or more movements in a pipe system occur at the same time. If multiple movements exceed single arch design there may be a need for additional arches. To perform calculation for concurrent movement when a pipe system design has more than one movement, please use the following formula:  

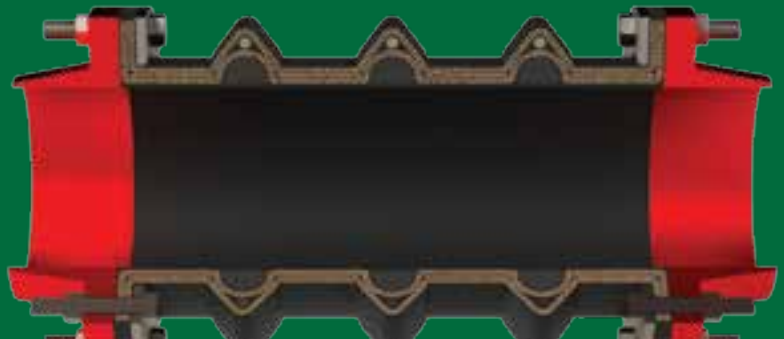
$$\frac{\text{Actual Axial Compression} + \text{Actual Axial Extension} + \text{Actual Lateral (X)} + \text{Actual Lateral (Y)}}{\text{Rated Axial Compression} + \text{Rated Axial Extension} + \text{Rated Lateral (X)} + \text{Rated Lateral (Y)}} = / < 1$$
 Calculation must be equal to or less than 1 for expansion joint to operate within concurrent movement capability.
- Pressure rating is based on 170° F operating temperature with a 4:1 safety factor. At higher temperatures, the pressure rating is reduced slightly. Hydrostatic testing at 1.5 times rated maximum catalog pressure or design working pressure of pipe system for 10 minutes is available upon request.
- Weights are approximate.
- The degree of angular movement is based on the maximum rated extension.
- Torsional movement is expressed when the expansion joint is at neutral length.
- Calculation of Thrust (Thrust Factor). When expansion joints are installed in the pipeline, the static portion of the thrust is calculated as a product of the area of the I.D. of the arch of the expansion joint times the maximum pressure (design, test or surge) that will occur in the line. The result is a force expressed in pounds. Take Design, surge or test pressure X thrust factor to calculate end thrust.

“Effective Area”

Thrust Factor=

$$T = \frac{\pi}{4} (D)^2 (P)$$

T= Thrust  
P= PSI (Design, Test or Surge)  
D= Arch I.D.



7. Parts listed at 26" Hg / 660 mm Hg vacuum have a design rating of 30" Hg / 762 mm Hg (full vacuum). Vacuum rating is based on neutral installed length, without external load.

# Style 234-L Performance Data

**Table 4: Sizes • Movements • Design Pressures • Weights**

Expansion Joint Size Nom. I.D. Inch / (mm)	Neutral Length Inch / (mm)	234-L Movement Capability: <sup>1</sup> From Neutral Position (Non-Concurrent)					Operating Conditions <sup>2</sup>			Weights lbs / (kgs) <sup>3</sup>	
		Axial Compression Inch / (mm)	Axial Extension Inch / (mm)	Lateral Deflection Inch / (mm)	Angular Deflection <sup>4</sup> (Degrees)	Torsional Rotation <sup>5</sup> (Degrees)	Thrust Factor <sup>6</sup> In2 / (cm2)	Positive PSIG (Bar)	Vacuum Inches of Hg / (mm of Hg) <sup>7</sup>	Expansion Joint	Retaining Ring Set
<b>2</b> (50)	18 (457)	2.75 (70)	1.97 (50)	8 (200)	63.1°	2°	10.03 (64)	145 (10)	26 (660)	6.0 (2.8)	4.0 (1.8)
<b>2.5</b> (65)	18 (457)	2.75 (70)	1.97 (50)	8 (200)	57.6°	2°	13.04 (84)	145 (10)	26 (660)	7.0 (3.4)	4.5 (2.0)
<b>3</b> (80)	18 (457)	2.75 (70)	1.97 (50)	8 (200)	52.7°	2°	16.44 (106)	145 (10)	26 (660)	11.0 (5.1)	5.5 (2.5)
<b>4</b> (100)	18 (457)	2.75 (70)	1.97 (50)	8 (200)	44.5°	2°	24.41 (157)	145 (10)	26 (660)	15.0 (6.6)	8.0 (3.6)
<b>5</b> (125)	18 (457)	2.75 (70)	1.97 (50)	8 (200)	38.2°	2°	33.95 (219)	145 (10)	26 (660)	18.0 (8.1)	8.5 (3.9)
<b>6</b> (150)	24 (610)	2.75 (70)	1.97 (50)	8 (200)	33.3°	2°	45.06 (290)	145 (10)	26 (660)	31.0 (14.1)	9.5 (4.3)
<b>8</b> (200)	24 (610)	2.75 (70)	1.97 (50)	8 (200)	26.2°	2°	72.00 (469)	145 (10)	26 (660)	41.0 (18.4)	14.5 (6.6)
<b>10</b> (250)	24 (610)	2.75 (70)	1.97 (50)	8 (200)	21.5°	2°	105.22 (678)	145 (10)	26 (660)	50.0 (22.6)	17.0 (7.7)
<b>12</b> (300)	26 (660)	2.75 (70)	1.97 (50)	8 (200)	18.2°	2°	153.25 (988)	145 (10)	26 (660)	66.0 (30.0)	24.5 (33.5)
<b>14</b> (350)	26 (660)	3.15 (80)	2.36 (60)	8 (200)	18.6°	2°	200.27 (1292)	145 (10)	26 (660)	82.0 (37.3)	27.0 (12.2)
<b>16</b> (400)	26 (660)	3.15 (80)	2.36 (60)	8 (200)	16.5°	2°	253.58 (1636)	145 (10)	26 (660)	97.0 (44.1)	33.5 (15.2)
<b>18</b> (450)	26 (660)	3.15 (80)	2.36 (60)	8 (200)	14.7°	2°	313.17 (2020)	145 (10)	26 (660)	107.0 (48.7)	34.0 (15.4)
<b>20</b> (500)	26 (660)	3.15 (80)	2.36 (60)	8 (200)	13.3°	2°	379.05 (2445)	145 (10)	26 (660)	141.0 (63.8)	38.0 (17.2)
<b>24</b> (600)	26 (660)	3.15 (80)	2.36 (60)	8 (200)	11.1°	2°	562.25 (3627)	109 (7.5)	26 (660)	180.0 (81.4)	48.0 (21.8)
<b>28</b> (700)	30 (762)	3.15 (80)	2.36 (60)	8 (200)	9.6°	2°	742.93 (4793)	109 (7.5)	26 (660)	260.0 (117.9)	55.0 (24.9)

See Notes Page 4

**Table 4: Sizes • Movements • Design Pressures • Weights**

Expansion Joint Size Nom. I.D. Inch / (mm)	Neutral Length Inch / (mm)	234-L Movement Capability: <sup>1</sup> From Neutral Position (Non-Concurrent)					Operating Conditions <sup>2</sup>			Weights lbs / (kgs) <sup>3</sup>	
		Axial Compression Inch / (mm)	Axial Extension Inch / (mm)	Lateral Deflection Inch / (mm)	Angular Deflection <sup>4</sup> (Degrees)	Torsional Rotation <sup>5</sup> (Degrees)	Thrust Factor <sup>6</sup> In <sup>2</sup> / (cm <sup>2</sup> )	Positive PSIG (Bar)	Vacuum Inches of Hg / (mm of Hg) <sup>7</sup>	Expansion Joint	Retaining Ring Set
<b>30</b> (750)	30 (762)	3.15 (80)	2.36 (60)	8 (200)	8.9°	2°	842.69 (5436)	73 (5)	26 (660)	278.0 (126.3)	63.0 (28.6)
<b>36</b> (900)	30 (762)	3.15 (80)	2.36 (60)	8 (200)	7.5°	2°	1179.68 (7610)	73 (5)	26 (660)	341.0 (154.6)	76.0 (34.5)
<b>42</b> (1050)	32 (813)	3.15 (80)	2.36 (60)	8 (200)	6.4°	2°	1573.22 (10149)	73 (5)	26 (660)	468.0 (212.3)	100.0 (45.4)
<b>48</b> (1200)	32 (813)	3.15 (80)	2.36 (60)	8 (200)	5.6°	2°	2023.31 (13053)	73 (5)	26 (660)	567.0 (257.3)	132.0 (59.9)
<b>54</b> (1350)	32 (813)	3.15 (80)	2.36 (60)	8 (200)	5.0°	2°	2460.24 (15872)	73 (5)	26 (660)	646.0 (293.2)	150.0 (68.0)
<b>60</b> (1500)	38 (965)	3.15 (80)	2.36 (60)	8 (200)	4.5°	2°	3016.00 (19458)	73 (5)	26 (660)	834.0 (378.5)	200.0 (90.7)

NOTES:

- Concurrent Movements - Concurrent movements are developed when two or more movements in a pipe system occur at the same time. If multiple movements exceed single arch design there may be a need for additional arches. To perform calculation for concurrent movement when a pipe system design has more than one movement, please use the following formula:  

$$\frac{\text{Actual Axial Compression} + \text{Actual Axial Extension} + \text{Actual Lateral (X)} + \text{Actual Lateral (Y)}}{\text{Rated Axial Compression} + \text{Rated Axial Extension} + \text{Rated Lateral (X)} + \text{Rated Lateral (Y)}} = / < 1$$
 Calculation must be equal to or less than 1 for expansion joint to operate within concurrent movement capability.
- Pressure rating is based on 170° F operating temperature with a 4:1 safety factor. At higher temperatures, the pressure rating is reduced slightly. Hydrostatic testing at 1.5 times rated maximum catalog pressure or design working pressure of pipe system for 10 minutes is available upon request.
- Weights are approximate.
- The degree of angular movement is based on the maximum rated extension.
- Torsional movement is expressed when the expansion joint is at neutral length.
- Calculation of Thrust (Thrust Factor). When expansion joints are installed in the pipeline, the static portion of the thrust is calculated as a product of the area of the I.D. of the arch of the expansion joint times the maximum pressure (design, test or surge) that will occur in the line. The result is a force expressed in pounds. Take Design, surge or test pressure X thrust factor to calculate end thrust.

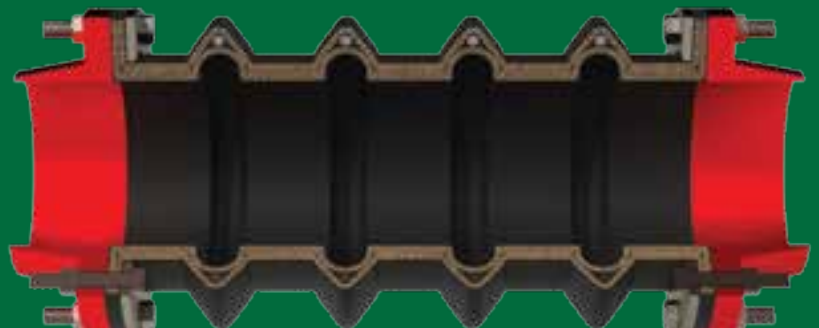
“Effective Area”

Thrust Factor=

$$T = \frac{\pi}{4} (D)^2 (P)$$

T= Thrust  
P= PSI (Design, Test or Surge)  
D= Arch I.D.

7. Parts listed at 26” Hg / 660 mm Hg vacuum have a design rating of 30” Hg / 762 mm Hg (full vacuum). Vacuum rating is based on neutral installed length without external load.



# Style FA234-L Performance Data

**Table 5: Sizes • Movements • Design Pressures • Spring Rates**

Expansion Joint Size Nom. I.D. Inch / (mm)	Neutral Length Inch / (mm)	Movement					Operating Conditions				Spring Rates			
		Axial Compression Inch / (mm)	Axial Extension Inch / (mm)	Lateral Deflection Inch / (mm)	Angular Deflection <sup>4</sup> (Degrees)	Torsional Rotation <sup>5</sup> (Degrees)	Thrust Factor <sup>6</sup> In <sup>2</sup> / (cm <sup>2</sup> )	Maximum Pressure Rating PSIG / (Bar)	Maximum Vacuum Rating In. Hg. / (mm of Hg)	Axial Compression lbs./in. / (N/mm)	Axial Extension lbs./in. / (N/mm)	Lateral Deflection lbs./in. / (N/mm)	Angular Deflection ft.-lbs. <sup>6</sup> / (Nm/ <sup>6</sup> )	
<b>2</b> (50)	18 (457)	1.38 (35)	1 (25)	4 (100)	31.5°	1°	3.14 (20)	145 (10)	26 (660)	699 (121)	913 (159)	1158 (203)	0.49 (0.66)	
<b>2.5</b> (65)	18 (457)	1.38 (35)	1 (25)	4 (100)	28.8°	1°	4.91 (32)	145 (10)	26 (660)	875 (152)	1140 (198)	1259 (221)	0.83 (1.12)	
<b>3</b> (75)	18 (457)	1.38 (35)	1 (25)	4 (100)	26.3°	1°	7.07 (46)	145 (10)	26 (660)	1050 (183)	1369 (240)	1363 (238)	1.32 (1.79)	
<b>4</b> (100)	18 (457)	1.38 (35)	1 (25)	4 (100)	22.2°	1°	12.57 (81)	145 (10)	26 (660)	1402 (245)	1826 (320)	1574 (276)	3.14 (4.26)	
<b>5</b> (125)	18 (457)	1.38 (35)	1 (25)	4 (100)	19.1°	1°	19.64 (127)	145 (10)	26 (660)	1749 (306)	2276 (399)	1806 (315)	7 (9)	
<b>6</b> (150)	24 (610)	1.38 (35)	1 (25)	4 (100)	16.6°	1°	28.27 (182)	145 (10)	26 (660)	2101 (386)	2732 (478)	2040 (357)	11 (15)	
<b>8</b> (200)	24 (610)	1.38 (35)	1 (25)	4 (100)	13.1°	1°	50.27 (324)	145 (10)	26 (660)	2335 (408)	3038 (531)	2489 (437)	22 (29)	
<b>10</b> (250)	24 (610)	1.38 (35)	1 (25)	4 (100)	10.7°	1°	78.54 (507)	145 (10)	26 (660)	2919 (512)	3797 (666)	2675 (467)	40 (53)	
<b>12</b> (300)	26 (660)	1.38 (35)	1 (25)	4 (100)	9.1°	1°	113.1 (730)	145 (10)	26 (660)	3502 (613)	4556 (798)	3136 (549)	71 (95)	
<b>14</b> (350)	26 (660)	1.57 (40)	1.18 (30)	4 (100)	9.3°	1°	153.94 (993)	145 (10)	26 (660)	3065 (536)	3987 (699)	3693 (646)	31 (42)	
<b>16</b> (400)	26 (660)	1.57 (40)	1.18 (30)	4 (100)	8.2°	1°	201.06 (1297)	145 (10)	26 (660)	3502 (613)	4556 (798)	4253 (745)	126 (170)	
<b>18</b> (450)	26 (660)	1.57 (40)	1.18 (30)	4 (100)	7.3°	1°	254.47 (1642)	145 (10)	26 (660)	3938 (690)	5129 (897)	4697 (822)	176 (238)	
<b>20</b> (500)	26 (660)	1.57 (40)	1.18 (30)	4 (100)	6.6°	1°	314.16 (2027)	145 (10)	26 (660)	4381 (767)	5689 (997)	5252 (919)	251 (342)	
<b>24</b> (600)	26 (660)	1.57 (40)	1.18 (30)	4 (100)	5.5°	1°	452.39 (2919)	109 (7.5)	26 (660)	5255 (919)	6829 (1195)	5643 (988)	452 (613)	
<b>28</b> (700)	30 (762)	1.57 (40)	1.18 (30)	4 (100)	4.8°	1°	615.75 (3973)	109 (7.5)	26 (660)	5451 (955)	7087 (1241)	6456 (1131)	631 (856)	

See Notes Page 4

**Table 5: Sizes • Movements • Design Pressures • Spring Rates**

Expansion Joint Size Nom. I.D. Inch / (mm)	Neutral Length Inch / (mm)	Movement					Operating Conditions			Spring Rates			
		Axial Compression Inch / (mm)	Axial Extension Inch / (mm)	Lateral Deflection Inch / (mm)	Angular Deflection <sup>4</sup> (Degrees)	Torsional Rotation <sup>5</sup> (Degrees)	Thrust Factor <sup>6</sup> In <sup>2</sup> / (cm <sup>2</sup> )	Positive PSIG (Bar)	Vacuum Inches of Hg / (mm of Hg) <sup>7</sup>	Axial Compression lbs/in. / (N/mm)	Axial Extension lbs/in. / (N/mm)	Lateral Deflection lbs/in. / (N/mm)	Angular Deflection ft-lbs/° / (Nm/°)
<b>30</b> (750)	30 (762)	1.57 (40)	1.18 (30)	4 (100)	4.4°	1°	706.86 (4560)	73 (5)	26 (660)	5841 (1023)	7596 (1330)	6862 (1202)	723 (981)
<b>36</b> (900)	30 (762)	1.57 (40)	1.18 (30)	4 (100)	3.7°	1°	1017.88 (6567)	73 (5)	26 (660)	7007 (1226)	9115 (1596)	10465 (1832)	1396 (2042)
<b>42</b> (1050)	32 (813)	1.57 (40)	1.18 (30)	4 (100)	3.2°	1°	1385.44 (8938)	73 (5)	26 (660)	7362 (1290)	9563 (1674)	11320 (1982)	1923 (2606)
<b>48</b> (1200)	32 (813)	1.57 (40)	1.18 (30)	4 (100)	2.8°	1°	1809.56 (11675)	73 (5)	26 (660)	8412 (1473)	10928 (1914)	12787 (2240)	3019 (4092)
<b>54</b> (1350)	32 (813)	1.57 (40)	1.18 (30)	4 (100)	2.5°	1°	2290.22 (14776)	73 (5)	26 (660)	9466 (1658)	12295 (2152)	14231 (2492)	3817 (5175)
<b>60</b> (1500)	38 (965)	1.57 (40)	1.18 (30)	4 (100)	2.2°	1°	2827.43 (18241)	73 (5)	26 (660)	10518 (1841)	13673 (2395)	15664 (2743)	5850 (7931)

NOTES:

1. Movements are Non-Concurrent

Concurrent movements are developed when two or more movements in a pipe system occur at the same time.

To perform calculations for concurrent movement when a pipe system design has more than one movement, please use the following formula:

$$\frac{\text{Actual Axial}}{\text{Rated Axial}} + \frac{\text{Actual Lateral}}{\text{Rated Lateral}} + \frac{\text{Actual Lateral}}{\text{Rated Lateral}} = \leq 1$$

Calculation must be equal to or less than 1 for expansion joint to operate within concurrent movement capabilities.

2. Pressure rating is based on 170° F operating temperature with a 4:1 safety factor. At higher temperatures, the pressure rating is reduced slightly. Hydrostatic testing at 1.5 times rated maximum pressure or design working pressure of pipe system for 10 minutes is available upon request.

3. The degree of angular movement is based on the maximum rated extension.

4. Torsional movement is expressed when the expansion joint is at neutral length.

5. Calculation of Thrust (Thrust Factor). When expansion joints are installed in the pipeline, the static portion of the thrust is calculated as a product of the area of the I.D. of the arch of the expansion joint times the maximum pressure (design, test or surge) that will occur in the line. The result is a force expressed in pounds.

Take Design, surge or test pressure X thrust factor to calculate end thrust.

“Effective Area”

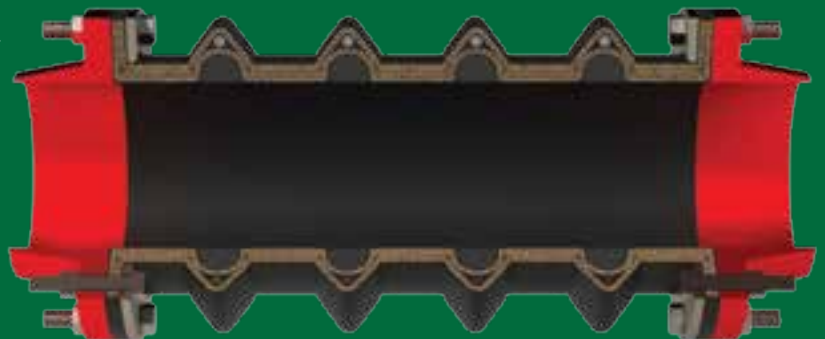
Thrust Factor=

$$T = \frac{\pi}{4} (D)^2 (P)$$

T= Thrust  
P= PSI (Design, Test or Surge)  
D= Arch I.D.

6. Parts listed at 26” Hg / 660 mm Hg vacuum have a design rating of 30” Hg / 762 mm Hg (full vacuum). Vacuum rating is based on neutral installed length, without external load. Products should not be installed “extended” on vacuum applications.

7. Spring Rates: The forces required to move the expansion joints are based on zero pressure conditions and room temperature in the pipe line.



# Style 233-L & 234-L Drilling Chart

Table 6		Standard Drilling for PROCO Rubber Expansion Joints							Thickness of Materials for PROCO Rubber Expansion Joints				
Nominal Pipe Size Expansion Joint I.D. Inch / (mm)		Flange Dimensions <sup>1,2</sup>							Material Thickness for Bolt Length Requirements				Adjacent Mating Flange Thickness
		Flange O.D. Inch / (mm)		Bolt Circle Inch / (mm)		Number Of Holes	Size Of Holes Inch / (mm)		Retaining Rings Thickness Inch / (mm)		Rubber Flange Thickness Inch / (mm)		
<b>2</b>	(50)	<b>6.00</b>	(152.40)	<b>4.75</b>	(120.65)		<b>4</b>	<b>0.750</b>	(19.05)	<b>0.375</b>	(9.53)	<b>0.472</b>	(11.99)
<b>2.5</b>	(65)	<b>7.00</b>	(177.80)	<b>5.50</b>	(139.70)	<b>4</b>	<b>0.750</b>	(19.05)	<b>0.375</b>	(9.53)	<b>0.472</b>	(11.99)	
<b>3</b>	(80)	<b>7.50</b>	(190.50)	<b>6.00</b>	(152.40)	<b>4</b>	<b>0.750</b>	(19.05)	<b>0.375</b>	(9.53)	<b>0.472</b>	(11.99)	
<b>4</b>	(100)	<b>9.00</b>	(228.60)	<b>7.50</b>	(190.50)	<b>8</b>	<b>0.750</b>	(19.05)	<b>0.375</b>	(9.53)	<b>0.472</b>	(11.99)	
<b>5</b>	(125)	<b>10.00</b>	(254.00)	<b>8.50</b>	(215.90)	<b>8</b>	<b>0.875</b>	(22.23)	<b>0.375</b>	(9.53)	<b>0.551</b>	(14.00)	
<b>6</b>	(150)	<b>11.00</b>	(279.40)	<b>9.50</b>	(241.30)	<b>8</b>	<b>0.875</b>	(22.23)	<b>0.375</b>	(9.53)	<b>0.551</b>	(14.00)	
<b>8</b>	(200)	<b>13.50</b>	(342.90)	<b>11.75</b>	(298.45)	<b>8</b>	<b>0.875</b>	(22.23)	<b>0.375</b>	(9.53)	<b>0.630</b>	(16.00)	
<b>10</b>	(250)	<b>16.00</b>	(406.40)	<b>14.25</b>	(361.95)	<b>12</b>	<b>1.000</b>	(25.40)	<b>0.375</b>	(9.53)	<b>0.630</b>	(16.00)	
<b>12</b>	(300)	<b>19.00</b>	(482.60)	<b>17.00</b>	(431.80)	<b>12</b>	<b>1.000</b>	(25.40)	<b>0.375</b>	(9.53)	<b>0.748</b>	(19.00)	
<b>14</b>	(350)	<b>21.00</b>	(533.40)	<b>18.75</b>	(476.25)	<b>12</b>	<b>1.125</b>	(28.58)	<b>0.375</b>	(9.53)	<b>0.866</b>	(22.00)	
<b>16</b>	(400)	<b>23.50</b>	(596.90)	<b>21.25</b>	(539.75)	<b>16</b>	<b>1.125</b>	(28.58)	<b>0.375</b>	(9.53)	<b>0.866</b>	(22.00)	
<b>18</b>	(450)	<b>25.00</b>	(635.00)	<b>22.75</b>	(577.85)	<b>16</b>	<b>1.250</b>	(31.75)	<b>0.375</b>	(9.53)	<b>0.866</b>	(22.00)	
<b>20</b>	(500)	<b>27.50</b>	(698.50)	<b>25.00</b>	(635.00)	<b>20</b>	<b>1.250</b>	(31.75)	<b>0.375</b>	(9.53)	<b>0.984</b>	(24.99)	
<b>22</b>	(550)	<b>29.50</b>	(749.30)	<b>27.25</b>	(692.15)	<b>20</b>	<b>1.375</b>	(34.93)	<b>0.375</b>	(9.53)	<b>0.984</b>	(24.99)	
<b>24</b>	(600)	<b>32.00</b>	(812.80)	<b>29.50</b>	(749.30)	<b>20</b>	<b>1.375</b>	(34.93)	<b>0.375</b>	(9.53)	<b>0.984</b>	(24.99)	
<b>26</b>	(650)	<b>34.25</b>	(869.95)	<b>31.75</b>	(806.32)	<b>24</b>	<b>1.375</b>	(34.93)	<b>0.375</b>	(9.53)	<b>0.984</b>	(24.99)	
<b>28</b>	(700)	<b>36.50</b>	(927.10)	<b>34.00</b>	(863.60)	<b>28</b>	<b>1.375</b>	(34.93)	<b>0.375</b>	(9.53)	<b>0.984</b>	(24.99)	
<b>30</b>	(750)	<b>38.75</b>	(984.25)	<b>36.00</b>	(914.40)	<b>28</b>	<b>1.375</b>	(34.93)	<b>0.375</b>	(9.53)	<b>0.984</b>	(24.99)	
<b>36</b>	(900)	<b>46.00</b>	(1168.40)	<b>42.75</b>	(1085.85)	<b>32</b>	<b>1.625</b>	(41.28)	<b>0.375</b>	(9.53)	<b>0.984</b>	(24.99)	
<b>42</b>	(1050)	<b>53.00</b>	(1346.20)	<b>49.50</b>	(1257.30)	<b>36</b>	<b>1.625</b>	(41.28)	<b>0.375</b>	(9.53)	<b>1.181</b>	(30.00)	
<b>48</b>	(1200)	<b>59.50</b>	(1511.30)	<b>56.00</b>	(1422.40)	<b>44</b>	<b>1.625</b>	(41.28)	<b>0.375</b>	(9.53)	<b>1.181</b>	(30.00)	
<b>54</b>	(1350)	<b>66.25</b>	(1682.75)	<b>62.75</b>	(1593.85)	<b>44</b>	<b>2.000</b>	(50.80)	<b>0.375</b>	(9.53)	<b>1.181</b>	(30.00)	
<b>60</b>	(1500)	<b>73.00</b>	(1854.20)	<b>69.25</b>	(1758.95)	<b>52</b>	<b>2.000</b>	(50.80)	<b>0.375</b>	(9.53)	<b>1.181</b>	(30.00)	

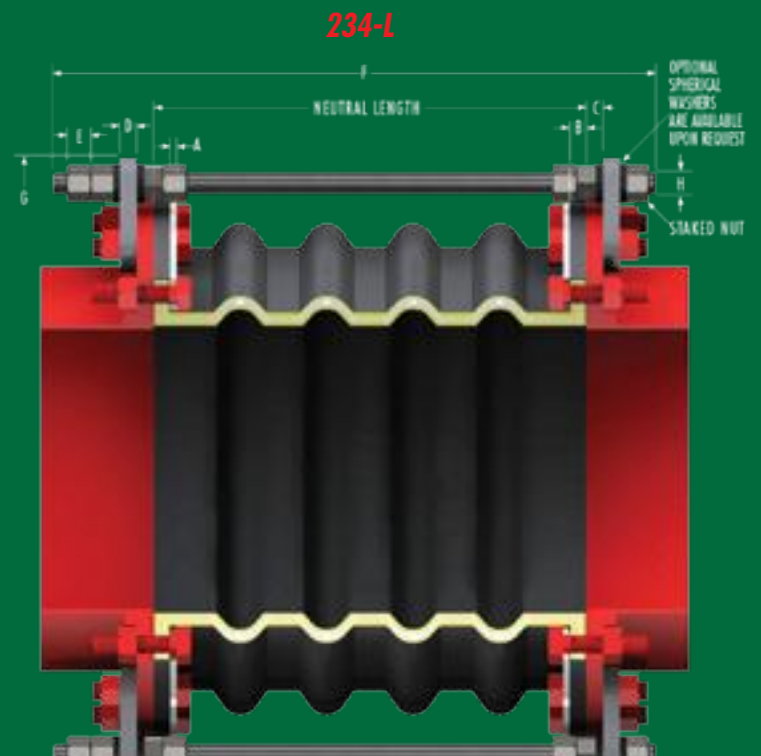
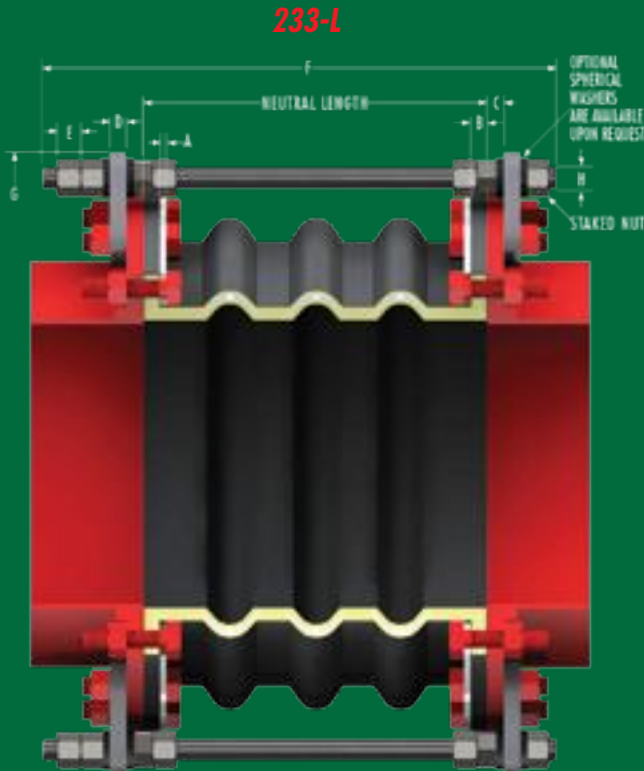
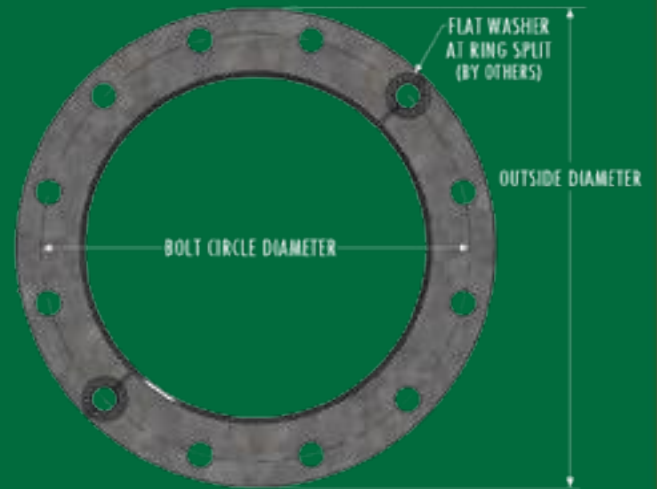
Metric Conversion Formula: Nominal I.D.: in. x 25 = mm; Dimensions/Thickness': in. x 25.4 = mm.

**Notes:**

1. Flange Dimensions shown are in accordance with ANSI B16.1 and ANSI B16.5 Class 125/150, AWWA C-207-07, Tbl 2 and 3 - Class D, Table 4 - Class E. Hole size shown is 1/8" larger than AWWA Standard.
2. Additional flange drilling such as 300 LB., PN10, PN16 and other special drilling's are available upon request.

# Limit Rods Upon Request

- A** - Retaining Ring Thickness.
- B** - Rubber Flange Thickness.
- C** - Adjacent Mating Flange Thickness (By Others).
- D** - Control Unit Plate Thickness.
- E** - Double Nut Thickness is determined by Control Rod Diameter.
- F** - Control Rod Bolt Length is determined by A through E + OAL <sup>1</sup>.
- G** - Control Rod Plate O.D.
- H** - Maximum Rod Diameter



# Installation Instructions for Non-Metallic Expansion Joints

## 1. Service Conditions:

Make sure the expansion joint rating for temperature, pressure, vacuum and movements match the system requirements. Contact the manufacturer for advice if the system requirements exceed those of the expansion joint selected. Check to make sure the elastomer selected is chemically compatible with the process fluid or gas.

## 2. Alignment:

Expansion joints are normally not designed to make up for piping misalignment errors. Piping should be lined up within 1/8". Misalignment reduces the rated movements of the expansion joint and can induce severe stress and reduce service life. Pipe guides should be installed to keep the pipe aligned and to prevent undue displacement.

## 3. Anchoring:

Solid anchoring is required wherever the pipeline changes direction and expansion joints should be located as close as possible to anchor points. If piping is not adequately anchored, control rods should be used. If anchors are not used, pressure thrust may cause excessive movement damaging the expansion joint.

## 4. Pipe Support:

Piping must be supported by hangers or anchors so expansion joints do not carry any pipe weight.

## 5. Mating Flanges:

Install the expansion joint against the mating pipe flanges and install bolts so that the bolt head and washer are against the retaining rings. If washers are not used, flange leakage can result – particularly at the split in the retaining rings. Flange-to-flange dimension of the expansion joint must match the breech opening. Make sure the mating flanges are clean and are flat faced type or no more than 1/16" raised face type. Never install expansion joints that utilize split retaining rings next to wafer type check or butterfly valves. Serious damage can result to a rubber joint of this type unless installed against full face flanges.

## 6. Bolting Torque:

Table 7 shows the recommended torque ranges for non-metallic expansion joints with full-faced rubber flanges: Torque specifications are approximate. Tighten bolts in stages using cross-bolt tightening pattern. If the joint has integral fabric and rubber flanges, the bolts should be tight enough to make the rubber flange OD bulge between the retaining rings and the mating flange. After installation, the system should be pressurized and examined to confirm a proper seal. Torque bolts sufficiently to assure leak-free operation at hydrostatic test pressure. *Note: Torque values are approximate due to mating flange surfaces, installation offsets, operating pressures and environmental conditions.*

Table 7 Size	Approximate Torque Values
1" THRU 2"	20 - 40 ft/lbs
2.5" THRU 5"	25 - 60 ft/lbs
6" THRU 12"	35 - 140 ft/lbs
14" THRU 18"	50 - 180 ft/lbs
20" THRU 24"	60 - 200 ft/lbs
26" THRU 40"	70 - 300 ft/lbs
42" THRU 60"	80 - 300 ft/lbs

## 7. Storage:

Ideal storage is in a warehouse with a relatively dry, cool location. Store flanges face down on a pallet or wooden platform. Do not store other heavy items on top of expansion joints. Ten year shelf life can be expected with ideal conditions. If storage must be outdoors, place on wooden platform and joints should not be in contact with the ground. Cover with a tarpaulin.

## 8. Large Joint Handling:

Do not lift with ropes or bars through the bolt holes. If lifting through the bore, use padding or a saddle to distribute the weight. Make sure cables or forklift tines do not contact the rubber. Do not let expansion joints sit vertically on the edges of the flanges for any period of time.

## 9. Additional Tips:

- Do not insulate over a non-metallic expansion joint; however, if insulation is required, it should be made removable to permit easy access to the flanges. This facilitates periodic inspection of the tightness of the joint bolting.
- It is acceptable (but not necessary) to lubricate the expansion joint flanges with a thin film of graphite dispersed in glycerin or water to ease disassembly at a later time.
- Do not weld in the near vicinity of a non-metallic joint.
- If expansion joints are to be installed underground, or will be submerged in water, contact manufacturer for specific recommendations.
- If the expansion joint will be installed outdoors, make sure the cover material will withstand ozone, sunlight, etc.
- Check the tightness of lead-free flanges two or three weeks after installation and retighten if necessary.

*Warning: Expansion joints may operate in pipelines or equipment carrying fluids and/or gasses at elevated temperature and pressures and may transport hazardous materials. Precautions should be taken to protect personnel in the event of leakage or splash. Rubber joints should not be installed in areas where insertion is*

# Settlement Examples

Tank Before Settlement



Tank After Settlement



**ALSO AVAILABLE FROM  
Proco Products, Inc.**

Proco Products, Inc. can supply tied universal expansion joints or hinged universal expansion joints for large lateral movements.



**Hinged Assembly**



**Tied Rod Assembly**



2431 North Wigwam Dr. (95205)  
P.O. Box 590 • Stockton, CA  
95201-0590 • USA

Toll-Free Phone: (800) 344-3246

Facsimile: (209) 943-0242

(209) 943-6088

email: [sales@procoproducts.com](mailto:sales@procoproducts.com)

**NATIONWIDE AND CANADA**

**INTERNATIONAL**



Industrial Distributor Co-op



**REPRESENTED BY:**

**GOODYEAR**  
RUBBER PRODUCTS, INC.

**727-342-5088**

You can also email us at  
[GRP@goodyearrubberproducts.com](mailto:GRP@goodyearrubberproducts.com)

# PROCO

*The Expansion Joint and Check Valve People*



**WELDED SPHERICAL JOINTS STYLE 240/242**

**GOODYEAR**  
RUBBER PRODUCTS, INC.

☎ 727-342-5088

You can also email us at  
[GRP@goodyearrubberproducts.com](mailto:GRP@goodyearrubberproducts.com)

# Proco Style 240/242 Molded Spherical Joints

**Proco Style 240/242** Spherical Molded Expansion Joints are designed for piping systems to absorb pipe movements, relieve stress, reduce system noise/vibration, compensate for misalignment/offset and to protect rotating mechanical equipment against start-up surge forces.

The molded style 240 single sphere and 242 twin sphere designed bellows are inherently stronger than the conventional hand-built style spool arch type. Internal pressure within a "sphere" is exerted in all directions, distributing forces evenly over a larger area. The spherical design "flowing arch" reduces turbulence and sediment buildup.

## Features and Benefits:

### Absorbs Directional Movement

Thermal movements appear in any rigid pipe system due to temperature changes. The Style 240 and Style 242 spherical arch expansion joints allow for axial compression or axial extension, lateral deflection as well as angular movement. (Note: Rated movements in this publication are based on single plane movements. Multiple movement conditions are based on a multiple movement calculation. Contact Proco for information when designing multiple pipe movements.)

### Easy Installation with Rotating Metallic Flanges

The floating metallic flanges freely rotate on the bellows, compensating for mating flange misalignment, thus speeding up installation time. Gaskets are not required with the Style 240 or Style 242, provided the expansion joints are mated against a flat face flange as required in the installation instructions.

### Flange Materials/Drilling

The Proco Style 240 and Style 242 molded expansion joints are furnished complete with plated carbon steel flanges for corrosion protection. 304 or 316 stainless steel flanges are available upon request as well as ANSI 250/300 lb., BS-10, DIN PN10 & PN16 and JIS-10K drilling.

### Absorbs Vibration, Noise and Shock

The Proco Style 240 and Style 242 molded expansion joints effectively dampen and insulate downstream piping against the transmission of noise and vibration generated by mechanical equipment. Noise and vibration caused by equipment can cause stress in pipe, pipe guides, anchors and other equipment downstream. Water hammer and pumping impulses can also cause strain, stress or shock to a piping system. Install the Style 240 or Style 242 molded expansion joints to help compensate for these system pressure spikes.

### Wide Service Range with Low Cost

Engineered to operate up to 300 PSIG or 265°F, the Proco Style 240 and Style 242 can be specified for a wide range of piping requirements. Compared to conventional hand-built spool type joints, you will invest less money when specifying the mass-produced, consistent high quality, molded single or twin sphere expansion joints.

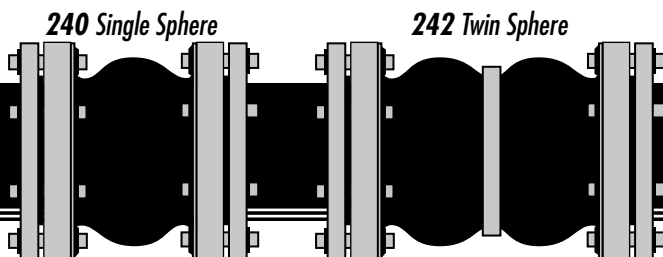
### Material Identification

All Style 240 or Style 242 molded expansion joints have branded elastomer designations. Neoprene Tube/Neoprene Cover (NN) and Nitrile Tube/Neoprene Cover (NP) elastomer designated joints meet the Coast Guard Requirements and conform to ASTM F1123-87. 240C/NP-9 joints have ABS certification.

### Large Inventory

Proco Products, Inc. maintains one of the largest inventories of rubber expansion joints in the world. Please contact us for price and availability.

Table 1: Available Styles • Materials								
For Specific Elastomer Recommendations, See: <b>PROCO</b> "Chemical To Elastomer Guide"								
240-A	240-C	240-AV,D,E,M <sup>11</sup>	242-A,B,C	PROCO Material Code	Cover Elastomer <sup>1</sup>	Tube Elastomer <sup>2</sup>	Maximum Operating Temp. °F	Identifying Color Band/Label
		X	X	/BB <sup>3</sup>	Chlorobutyl	Chlorobutyl	250°	Black
		X	X	/EE <sup>2,3,7</sup>	EPDM	EPDM	250°	Red
X	X			/EE <sup>2,3,4</sup>	EPDM	FDA-EPDM	250°	Red
		X		/EQ <sup>2,3</sup>	EPDM	FDA-EPDM	250°	Red
X	X			/EE-9 <sup>3,5</sup>	EPDM	EPDM	265°	DBL Red
		X		/HH	CSM	CSM	212°	Green
	X	X	X	/NH	Neoprene	CSM	212°	Green
	X	X	X	/NJ <sup>2</sup>	Neoprene	FDA-Nitrile	212°	White
	X	X	X	/NN <sup>7</sup>	Neoprene	Neoprene	225°	Blue
X	X	X	X	/NP	Neoprene	Nitrile	212°	Yellow
X	X			/NP-9 <sup>6</sup>	Neoprene	Nitrile-ABS	212°	DBL Yellow



Protecting Piping and Equipment Systems from Stress/Motion

Notes: All Products are reinforced with Nylon Tire Cord, except 240-A and 240-C which are reinforced with Polyester.

1. All NN & NP elastomer designated joints meet the Coast Guard Requirements and conform to ASTM F 1123-87 and are marked accordingly.
2. Branding Label will be marked as "Food Grade".

6. NP-9 joints have ABS certification.

7. Elastomers are in accordance with NSF/ANSI 372, File MH47689 Und. Lab. Classified.

8. All elastomers above are not intended for steam service.

9. For PTFE lined single sphere see [www.procoproducts.com/ptfelined.html](http://www.procoproducts.com/ptfelined.html)

10. For 240A & 240C Rubber Joints, Vacuum Support devices are available

# Style 240 Single Sphere Performance Data

**Table 2: Sizes • Movements • Pressures • Flange Standards • Weights**

NOMINAL Pipe Size I.D.	Neutral Length	PROCO Style Number <sup>1</sup>	240 Movement Capability: From Neutral Position (Non-Concurrent) <sup>2</sup>					Pressure <sup>4</sup>		Standard Flange Drilling Dimensions <sup>8</sup>					Weight in lbs	
			Axial Compression Inches	Axial Extension Inches	Lateral Deflection Inches	Angular Deflection Degrees	Thrust Factor <sup>3</sup>	Positive PSIG <sup>5,9</sup>	Vacuum <sup>6</sup> Inches of Hg	Flange O.D. Inches	Bolt Circle Inches	Number of Holes	Size of Holes Inches	Bolt Hole <sup>7</sup> Thread	Exp. Joint & Flanges	Control Unit Set (2 Rod)
<b>1</b> (25)	5.00	240-C	1.063	1.250	1.188	45	4.43	225	26	4.25	3.13	4	0.625	1/2-13 UNC	3.8	3.3
	6.00	240-AV	0.500	0.375	0.500	37										
<b>1.25</b> (32)	3.74	240-D	0.312	0.188	0.312	45	6.34	225	26	4.63	3.5	4	0.625	—	4.6	3.3
	5.00	240-C	1.063	1.250	1.188	17										
	5.00	240-E	0.500	0.375	0.500	31										
	6.00	240-AV	0.500	0.375	0.500	31										
<b>1.5</b> (40)	3.74	240-D	0.375	0.188	0.312	14	6.49	225	26	5.0	3.88	4	0.625	—	5.4	4.6
	4.00	240-M	0.375	0.188	0.312	14										
	5.00	240-C	1.063	1.250	1.188	45										
	5.00	240-E	0.500	0.375	0.500	27										
	6.00	240-AV	0.500	0.375	0.500	27										
<b>2</b> (50)	4.00	240-M	0.375	0.188	0.312	11	7.07	225	26	6.0	4.75	4	0.750	—	8.3	6.3
	4.13	240-D	0.375	0.188	0.312	11										
	5.00	240-C	1.063	1.250	1.188	45										
	5.00	240-E	0.375	0.375	0.500	20										
	6.00	240-A	1.188	1.188	1.188	45										
	6.00	240-AV	0.500	0.375	0.500	20										
	6.00	Q-240-HW	0.500	0.375	0.500	20										
<b>2.5</b> (65)	4.00	240-M	0.375	0.188	0.375	8	11.05	225	26	7.0	5.5	4	0.750	—	12.0	7.6
	4.53	240-D	0.500	0.188	0.375	11										
	5.00	240-C	1.063	1.250	1.188	45										
	5.00	240-E	0.500	0.375	0.500	17										
	6.00	240-A	1.188	1.188	1.188	43										
	6.00	240-AV	0.500	0.375	0.500	17										
<b>3</b> (80)	5.00	240-C	1.063	1.250	1.188	40	13.36	235	15	7.5	6.0	4	0.750	—	13.3	8.3
	5.00	240-E	0.500	0.375	0.500	14										
	5.12	240-D	0.500	0.375	0.500	14										
	6.00	240-A	1.188	1.188	1.188	38										
	6.00	240-AV	0.500	0.375	0.500	14										
	6.00	240-AV	0.500	0.375	0.500	14										
	8.00	240-AV	0.500	0.375	0.500	14										
	6.00	Q-240-HW	0.500	0.375	0.500	14										
<b>3.5</b> (90)	6.00	240-AV	0.500	0.375	0.500	12	18.67	225	26	8.5	7.0	8	0.750	5/8-11 UNC	17.6	7.4
<b>4</b> (100)	5.00	240-C	1.063	1.250	1.188	32	22.69	235	15	9.0	7.5	8	0.750	—	16.5	7.4
	5.00	240-E	0.750	0.500	0.500	14										
	5.32	240-D	0.750	0.500	0.500	14										
	6.00	240-A	1.188	1.188	1.188	30										
	6.00	240-AV	0.750	0.500	0.500	14										
	6.00	240-AV	0.750	0.500	0.500	14										
	6.00	Q-240-HW	0.750	0.500	0.500	14										
<b>5</b> (125)	5.00	240-C	1.063	1.250	1.188	27	30.02	235	10	10.0	8.5	8	0.875	—	20.3	8.3
	5.00	240-E	0.750	0.500	0.500	11										
	6.00	240-A	1.188	1.188	1.188	25										
	6.00	240-AV	0.750	0.500	0.500	11										
	6.69	240-D	0.750	0.500	0.500	11										
	8.00	240-AV	0.750	0.500	0.500	11										
	6.00	Q-240-HW	0.750	0.500	0.500	11										

# Style 240 Single Sphere Performance Data

**Table 2: Sizes • Movements • Pressures • Flange Standards • Weights**

NOMINAL Pipe Size I.D.	Neutral Length	PROCO Style Number <sup>1</sup>	240 Movement Capability: From Neutral Position (Non-Concurrent) <sup>2</sup>					Pressure <sup>4</sup>		Standard Flange Drilling Dimensions <sup>8</sup>					Weight in lbs	
			Axial Compression Inches	Axial Extension Inches	Lateral Deflection Inches	Angular Deflection Degrees	Thrust Factor <sup>3</sup>	Positive PSIG <sup>5,9</sup>	Vacuum <sup>6</sup> Inches of Hg	Flange O.D. Inches	Bolt Circle Inches	Number of Holes	Size of Holes Inches	Bolt Hole <sup>7</sup> Thread	Exp. Joint & Flanges	Control Unit Set (2 Rod)
<b>6</b> (150)	5.00	240-C	1.063	1.250	1.188	23	41.28	225	8	11.0	9.5	8	0.875	—	22.6	10.4
	5.00	240-E	0.750	0.500	0.500	9		225	26	11.0	9.5	8	0.875	—	26.0	10.4
	6.00	240-A	1.188	1.188	1.188	21		235	10	11.0	9.5	8	0.875	—	24.0	10.4
	6.00	240-AV	0.750	0.500	0.500	9		225	26	11.0	9.5	8	0.875	3/4-10 UNC	26.8	10.4
	7.09	240-D	0.750	0.500	0.500	9		225	26	11.0	9.5	8	0.875	—	29.0	10.6
	8.00	240-AV	0.750	0.500	0.500	9		225	26	11.0	9.5	8	0.875	3/4-10 UNC	29.1	10.8
	6.00	Q-240-HW	0.750	0.500	0.500	9		300	26	12.5	10.62	12	0.875	—	39.0	10.4
<b>8</b> (200)	5.00	240-C	1.063	1.188	1.188	17	63.62	235	8	13.5	11.75	8	0.875	—	35.5	13.4
	5.00	240-E	0.750	0.500	0.500	7		225	26	13.5	11.75	8	0.875	—	40.0	13.4
	6.00	240-A	1.188	1.188	1.188	16		235	8	13.5	11.75	8	0.875	—	38.5	13.4
	6.00	240-AV	0.750	0.500	0.500	7		225	26	13.5	11.75	8	0.875	3/4-10 UNC	40.6	13.4
	8.07	240-D	1.000	0.563	0.875	8		225	26	13.5	11.75	8	0.875	—	41.3	14.0
	6.00	Q-240-HW	0.750	0.500	0.500	7		300	26	15.0	13.00	12	1.000	—	70.0	13.4
<b>10</b> (250)	5.00	240-C	1.063	1.188	1.188	14	103.87	235	6	16.0	14.25	12	1.000	—	49.3	21.0
	5.00	240-E	1.000	0.625	0.750	7		225	26	16.0	14.25	12	1.000	—	56.0	21.0
	8.00	240-A	1.188	1.188	1.188	13		145	6	16.0	14.25	12	1.000	—	53.6	21.3
	8.00	240-AV	1.000	0.625	0.750	7		225	26	16.0	14.25	12	1.000	7/8-9 UNC	56.6	21.3
	9.00	240-AV	1.000	0.625	0.750	7		225	26	16.0	14.25	12	1.000	7/8-9 UNC	57.0	22.0
	9.45	240-D	1.000	0.625	0.750	7		225	26	16.0	14.25	12	1.000	—	58.5	22.0
	10.00	240-AV	1.000	0.625	0.875	7		225	26	16.0	14.25	12	1.000	7/8-9 UNC	60.5	26.5
	8.00	Q-240-HW	1.000	0.625	0.750	7		275	26	17.5	15.25	16	1.125	—	56.0	22.0
<b>12</b> (300)	5.00	240-C	1.063	1.250	1.188	12	137.89	235	6	19.0	17.0	12	1.000	—	73.4	26.5
	5.00	240-E	1.000	0.625	0.750	6		225	26	19.0	17.0	12	1.000	—	74.0	26.5
	8.00	240-A	1.188	1.188	1.188	11		145	6	19.0	17.0	12	1.000	—	80.0	27.0
	8.00	240-AV	1.000	0.625	0.750	6		225	26	19.0	17.0	12	1.000	7/8-9 UNC	83.0	27.0
	9.00	240-AV	1.000	0.625	0.750	6		225	26	19.0	17.0	12	1.000	7/8-9 UNC	88.0	27.0
	10.24	240-D	1.000	0.625	0.875	6		225	26	19.0	17.0	12	1.000	—	89.0	28.0
	8.00	Q-240-HW	1.000	0.625	0.750	6		275	26	20.5	17.75	16	1.250	—	100.0	27.0
<b>14</b> (350)	8.00	240-C	1.000	1.063	1.188	8	182.65	232	6	21.0	18.75	12	1.125	—	112.0	28.0
	8.00	240-AV	1.000	0.625	0.750	6		150	26	21.0	18.75	12	1.125	—	115.0	28.0
<b>16</b> (400)	8.00	240-C	1.000	1.063	1.188	8	240.53	232	6	23.5	21.25	16	1.125	—	136.0	26.8
	8.00	240-HW	1.000	0.625	0.750	4		175	26				1.125	—	186.0	26.8
	8.00	240-AV	1.000	0.625	0.750	4		125	26				1.125	—	165.0	26.8
	9.00	240-M	1.000	0.625	0.750	4		125	26				1.125	—	168.0	27.0
	10.43	240-D	1.000	0.625	0.875	4		125	26				1.125	—	170.0	27.0
<b>18</b> (450)	8.00	240-HW	1.000	0.625	0.750	4	298.65	175	26	25.0	22.75	16	1.250	—	209.0	31.4
	8.00	240-AV	1.000	0.625	0.750			125	26				1.250	—	168.0	31.4
	9.00	240-M	1.000	0.625	0.750			125	26				1.250	—	169.0	33.1
	10.43	240-D	1.000	0.625	0.875			125	26				1.250	—	170.0	33.1
<b>20</b> (500)	8.00	240-C	1.000	1.063	1.188	6	363.05	145	6	27.5	25.00	20	1.250	—	154.0	32.4
	8.00	240-HW	1.000	0.625	0.750	3		175	26				1.250	—	234.0	32.4
	8.00	240-AV	1.000	0.625	0.750	3		125	26				1.250	—	170.0	32.4
	9.00	240-M	1.000	0.625	0.750	3		125	26				1.250	—	173.0	34.1
	10.43	240-D	1.000	0.625	0.875	3		125	26				1.250	—	175.0	34.1
<b>24</b> (600)	8.00	240-C	1.000	1.063	1.188	5	510.70	145	6	32.5	29.5	20	1.375	—	214.0	44.0
	10.00	240-AV	1.000	0.625	0.750	3		110	26				1.375	—	255.0	45.5
	10.00	240-HW	1.000	0.625	0.750	3		160	26				1.375	—	297.0	45.5
	10.47	240-D	1.000	0.625	0.875	3		110	26				1.375	—	265.0	46.0
<b>30</b> (750)	10.00	240-AV	1.000	0.625	0.750	2	779.31	110	26	38.75	36.0	28	1.375	—	295.0	57.0

## NOTES:

**Standard Proco Style 240-AV Expansion Joints shown in Bold Type are considered Standards and are inventoried in large quantities.**

1. "HW" denotes Heavy Weight Construction. For sizes 2" I.D. thru 12" I.D., Proco will only offer these items with 300 lb. drilling and are denoted by Q-240-HW. All Q-240-HW units will only be sold with control units.
2. Concurrent Movements - Concurrent movements are developed when two or more movements in a pipe system occur at the same time. If multiple movements exceed single arch design there may be a need for an additional arch. To perform calculation for concurrent movement when a pipe system design has more than one movement, please use the following formula:  
$$\frac{\text{Actual Axial Compression} + \text{Actual Axial Extension} + \text{Actual Lateral (X)} + \text{Actual Lateral (Y)}}{\text{Rated Axial Compression} + \text{Rated Axial Extension} + \text{Rated Lateral (X)} + \text{Rated Lateral (Y)}} = / < 1$$
Calculation must be equal to or less than 1 for expansion joint to operate within concurrent movement capability.
3. Calculation of Thrust (Thrust Factor). When expansion joints are installed in the pipeline, the static portion of the thrust is calculated as a product of the area of the I.D. of the arch of the expansion joint times the maximum pressure (design, test or surge) that will occur in the line. The result is a force expressed in pounds. **Take design, surge or test pressure X thrust factor to calculate end thrust.**
4. Pressure rating is based on 170°F operating temperature. The pressure rating is reduced at higher temperatures.
5. Pressures shown at maximum "operating pressure". Test pressure is 1.5 times "operating pressure". Burst pressure is 4 times "operating pressure". If factory hydro-test is required, an additional joint per size must be purchased and tested. Once hydro-tested this joint may not be sent to field for installation as the beaded end will have taken a (compressed) set and can not be reused.
6. Vacuum rating is based on neutral installed length, without external load. Products should not be installed in extension for vacuum applications. Flattening of the arch in extended mode will cause the arch to collapse.
7. Style 240AV/NN and 240-D/NN (neoprene elastomer only) expansion joints 1.0" I.D. thru 12" I.D. are available with tapped (threaded) holes and must be specified at time of order.
8. In addition to standard 150 lb. drilled flanges, Proco can provide expansion joints listed above in 300 lb. drilling, BS-10 (British) drilling, Metric PN10 and PN16 drilling and JIS 10kg/cm drilling.
9. For PTFE lined single sphere see [www.procoproducts.com/pfeline.html](http://www.procoproducts.com/pfeline.html)

"Effective Area"

Thrust Factor=

$$T = \frac{\pi}{4} (D)^2 (P)$$

T= Thrust

P= PSI (Design, Test or Surge)

D= Arch I.D.



# Style 242 Twin Sphere Performance Data

**Table 3: Sizes • Movements • Pressures • Flange Standards • Weights**

NOMINAL Pipe Size I.D.	Neutral Length	PROCO Style Number <sup>1</sup>	242 Movement Capability: From Neutral Position (Non-Concurrent) <sup>2</sup>					Pressure <sup>4</sup>		Standard Flange Drilling Dimensions <sup>8</sup>					Weight in lbs		
			Axial Compression Inches	Axial Extension Inches	Lateral Deflection Inches	Angular Deflection Degrees	Thrust Factor <sup>3</sup>	Positive PSIG <sup>5</sup>	Vacuum <sup>6</sup> Inches of Hg	Flange O.D. Inches	Bolt Circle Inches	Number of Holes	Size of Holes Inches	Bolt Hole <sup>7</sup> Thread	Exp. Joint & Flanges	Control Unit Set (2 Rod)	
<b>1</b> (25)	10.00	242-C	2.000	1.188	1.750	45	4.43	225	26	4.25	3.13	4	0.625	—	5.2	3.6	
<b>1.25</b> (32)	7.0	242-A	2.000	1.188	1.750	45	6.34	225	26	4.63	3.5	4	0.625	1/2-13 UNC	5.3	3.5	
	7.0	242-HA						300					0.625	—	6.5	3.5	
	10.00	242-C						225					0.625	—	6.2	3.6	
<b>1.5</b> (40)	6.00	242-B	2.000	1.188	1.750	45	6.49	225	26	5.0	3.88	4	0.625	1/2-13 UNC	6.1	4.6	
	6.00	242-HB						300					0.625		—	7.6	4.6
	7.00	242-A						225					0.625		—	6.8	4.8
	7.00	242-HA						300					0.625		—	8.3	4.8
	10.00	242-C						225					0.625		—	7.7	5.1
<b>2</b> (50)	6.00	242-B	2.000	1.188	1.750	45	7.07	225	26	6.0	4.75	4	0.750	5/8-11 UNC	9.0	6.6	
	7.00	242-A						225					0.750		—	9.0	7.0
	10.00	242-C						235					0.750		—	10.2	7.3
	6.00	Q-242-HB						300					0.750		—	10.5	6.6
	7.00	Q-242-HA						300					0.750		—	10.5	7.0
<b>2.5</b> (65)	6.00	242-B	2.000	1.188	1.750	43	11.05	225	26	7.0	5.5	4	0.750	5/8-11 UNC	12.9	7.6	
	7.00	242-A						225					0.750		—	13.3	8.0
	10.00	242-C						225					0.750		—	14.5	8.4
	6.00	Q-242-HB						300					0.750		—	15.3	7.6
	7.00	Q-242-HA						300					0.750		—	15.8	8.0
<b>3</b> (80)	7.00	242-A	2.000	1.188	1.750	38	13.36	225	26	7.5	6.0	4	0.750	5/8-11 UNC	14.3	8.6	
	9.00	242-B						225					0.750	—	15.2	9.0	
	10.00	242-C						225					0.750	—	15.8	9.1	
	12.00	242-C						225					0.750	—	16.0	9.9	
	7.00	Q-242-HA						300					0.875	—	18.2	8.6	
<b>4</b> (100)	9.00	242-A	2.000	1.375	1.562	34	22.69	225	26	9.0	7.5	8	0.750	5/8-11 UNC	20.3	8.0	
	10.00	242-C						225					0.750	—	21.3	8.2	
	12.00	242-C						225					0.750	—	22.0	8.2	
	9.00	Q-242-HA						300					0.750	—	26.4	8.0	
	9.00	242-A						2.000					1.375	1.562	29	30.02	225
10.00	242-C	225	0.875	—	25.5	9.1											
12.00	242-C	225	0.875	—	26.0	9.1											
9.00	Q-242-HA	300	0.875	—	31.4	8.3											
9.00	242-A	2.000	1.375	1.562	25	41.28	225		26	11.0	9.5	8					0.875
10.00	242-C						225	0.875					—	30.5	11.9		
12.00	242-C						225	0.875					—	31.0	12.0		
14.00	242-C						225	0.875					—	32.0	12.0		
9.00	Q-242-HA						300	0.875					—	38.6	11.7		
<b>8</b> (200)	9.00	242-B	2.375	1.375	1.375	19	63.62	225	26	13.5	11.75	8	0.875	—	42.3	14.5	
	10.00	242-C						225					0.875	—	43.4	15.0	
	12.00	242-C						225					0.875	—	44.0	15.2	
	13.00	242-A						225					0.875	—	43.8	15.4	
	14.00	242-C						225					0.875	—	46.0	16.0	
	9.00	Q-242-HB						300					1.000	—	55.4	14.5	
	13.00	Q-242-HA						300					1.000	—	57.5	15.4	
<b>10</b>	12.00	242-B	2.375	1.375	1.375	15	103.87	225	26	16.0	14.25	12	1.000	—	64.1	23.5	
	13.00	242-A						225					1.000	—	65.5	24.5	
	14.00	242-C						225					1.000	—	66.7	24.5	

**Table 3: Sizes • Movements • Pressures • Flange Standards • Weights**

NOMINAL Pipe Size I.D.	Neutral Length	PROCO Style Number <sup>1</sup>	242 Movement Capability: From Neutral Position (Non-Concurrent) <sup>2</sup>					Pressure <sup>4</sup>		Standard Flange Drilling Dimensions <sup>8</sup>					Weight in lbs	
			Axial Compression Inches	Axial Extension Inches	Lateral Deflection Inches	Angular Deflection Degrees	Thrust Factor <sup>3</sup>	Positive PSIG <sup>5</sup>	Vacuum <sup>6</sup> Inches of Hg	Flange O.D. Inches	Bolt Circle Inches	Number of Holes	Size of Holes Inches	Bolt Hole <sup>7</sup> Thread	Exp. Joint & Flanges	Control Unit Set (2 Rod)
<b>12</b> (300)	12.00	<b>242-B</b>						225		19.0	17.00	12	1.000	—	94.0	30.0
	13.00	<b>242-A</b>						225		19.0	17.00	12	1.000	—	95.0	31.0
	14.00	242-C	2.375	1.375	1.375	13	137.89	225	26	19.0	17.00	12	1.000	7/8-9 UNC	99.1	31.0
	12.00	Q-242-HB						275		20.5	17.75	16	1.250	—	110.0	30.0
	13.00	Q-242-HA						275		20.5	17.75	16	1.250	—	110.0	31.0
<b>14</b> (350)	13.75	<b>242-A</b>	1.750	1.118	1.118	9	182.65	150	26	21.0	18.75	12	1.125	—	142.0	32.0
<b>16</b> (400)	12.00	242-C						125					1.125	—	154.0	28.8
	12.00	242-HC	1.750	1.118	1.118	8	240.53	175	26	23.5	21.25	16	1.125	—	190.0	28.8
	13.75	<b>242-A</b>						125					1.125	—	162.0	30.8
	13.75	242-HA						175					1.125	—	200.2	30.8
<b>18</b> (450)	12.00	242-C						125					1.250	—	168.0	35.1
	13.75	<b>242-A</b>	1.750	1.118	1.118	7	298.65	125	26	25.0	22.75	16	1.250	—	176.0	36.1
	13.75	242-HA						175					1.250	—	211.2	36.1
<b>20</b> (500)	12.00	242-C						125					1.250	—	202.0	35.0
	13.75	<b>242-A</b>	1.750	1.118	1.118	7	363.05	125	26	27.5	25.0	20	1.250	—	212.0	35.5
	13.75	242-HA						175					1.250	—	212.0	35.5
<b>24</b> (600)	12.00	242-C						110					1.375	—	220.0	47.0
	13.75	<b>242-A</b>	1.750	1.118	1.118	5	510.70	110	26	32.5	29.5	20	1.375	—	250.0	48.0
	13.75	242-HA						160					1.375	—	296.2	48.0
<b>30</b> (750)	12.00	242-C	1.750	1.118	1.118	4	779.31	110	26	38.75	36.0	28	1.375	—	300.0	62.0

**NOTES:**

Standard Proco Style 242-A Expansion Joints shown in Bold Type are considered Standards and are inventoried in large quantities.

1. "HW" denotes Heavy Weight Construction. For sizes 2" I.D. thru 12" I.D., Proco will only offer these items with 300 lb. drilling and are denoted by Q-242-HW. All Q-240-HW units will only be sold with control units.

2. Concurrent Movements - Concurrent movements are developed when two or more movements in a pipe system occur at the same time. If multiple movements exceed single arch design there may be a need for an additional arch.

To perform calculation for concurrent movement when a pipe system design has more than one movement, please use the following formula:

$$\frac{\text{Actual Axial Compression} + \text{Actual Axial Extension} + \text{Actual Lateral (X)} + \text{Actual Lateral (Y)}}{\text{Rated Axial Compression} + \text{Rated Axial Extension} + \text{Rated Lateral (X)} + \text{Rated Lateral (Y)}} = / < 1$$

Calculation must be equal to or less than 1 for expansion joint to operate within concurrent movement capability.

3. Calculation of Thrust (Thrust Factor). When expansion joints are installed in the pipeline, the static portion of the thrust is calculated as a product of the area of the I.D. of the arch of the expansion joint times the maximum pressure (design, test or surge) that will occur in the line. The result is a force expressed in pounds. Take design, surge or test pressure X thrust factor to calculate end thrust.

"Effective Area"

Thrust Factor=

$$T = \frac{\pi}{4} (D)^2 (P)$$

T= Thrust  
P= PSI (Design, Test or Surge)  
D= Arch I.D.

4. Pressure rating is based on 170°F operating temperature. The pressure rating is reduced at higher temperatures.

5. Pressures shown at maximum "operating pressure". Test pressure is 1.5 times "operating pressure". Burst pressure is 4 times "operating pressure". If factory hydro-test is required, an additional joint per size must be purchased and tested. Once hydro-tested this joint may not be sent to field for installation as the beaded end will have taken a (compressed) set and can not be reused.

6. Vacuum rating is based on neutral installed length, without external load. Products should not be installed in extension for vacuum applications. Flattening of the arch in extended mode will cause the arch to collapse.

7. Style 242A/NN (neoprene elastomer only) expansion joints 1.0" I.D. thru 12" I.D. are available with tapped (threaded) holes and must be specified at time of order.

# Style 240/242 Drilling Chart

**Table 4: Flange Drilling**

NOMINAL Pipe Size Inch (mm)	American 125/150# Conforms to ANSI B16.1 and B16.5					American 250/300# Conforms to ANSI B16.1 and B16.5					British Standard 10:1962 Conforms to BS 10 Table E					
	Flange Thickness	Flange O.D.	Bolt Circle	No. of Holes	Drilled Hole Size	Threaded Hole Size	Flange Thickness	Flange O.D.	Bolt Circle	No. of Holes	Hole Size	Flange Thickness	Flange O.D.	Bolt Circle	No. of Holes	Hole Size
<b>1</b> (25)	0.55 (14.0)	4.25 (108.0)	3.13 (79.4)	4	0.62 (15.9)	1/2 - 13 UNC	0.63 (16.0)	4.88 (124.0)	3.5 (88.9)	4	0.75 (19.1)	0.59 (15.0)	4.5 (114.0)	3.25 (82.6)	4	0.62 (15.9)
<b>1.25</b> (32)	0.55 (14.0)	4.63 (118.0)	3.5 (88.9)	4	0.62 (15.9)	1/2 - 13 UNC	0.63 (16.0)	5.25 (133.0)	3.88 (98.4)	4	0.75 (19.1)	0.59 (15.0)	4.75 (121.0)	3.44 (87.3)	4	0.62 (15.9)
<b>1.5</b> (40)	0.55 (14.0)	5.0 (127.0)	3.88 (98.4)	4	0.62 (15.9)	1/2 - 13 UNC	0.63 (16.0)	6.12 (156.0)	4.50 (114.3)	4	0.88 (22.2)	0.59 (15.0)	5.25 (133.0)	3.88 (98.4)	4	0.62 (15.9)
<b>2</b> (50)	0.63 (16.0)	6.0 (152.0)	4.75 (120.7)	4	0.75 (19.1)	5/8 - 11 UNC	0.71 (18.0)	6.50 (165.0)	5.00 (127.0)	8	0.75 (19.1)	0.63 (16.0)	6.0 (152.0)	4.5 (114.3)	4	0.75 (19.1)
<b>2.5</b> (65)	0.71 (18.0)	7.0 (178.0)	5.5 (139.7)	4	0.75 (19.1)	5/8 - 11 UNC	0.71 (18.0)	7.5 (191.0)	5.88 (149.2)	8	0.88 (22.2)	0.71 (18.0)	6.5 (165.0)	5.0 (127.0)	4	0.75 (19.1)
<b>3</b> (80)	0.71 (18.0)	7.5 (191.0)	6.0 (152.4)	4	0.75 (19.1)	5/8 - 11 UNC	0.79 (20.0)	8.25 (210.0)	6.62 (168.2)	8	0.88 (22.2)	0.71 (18.0)	7.25 (184.0)	5.75 (146.1)	4	0.75 (19.1)
<b>3.5</b> (90)	0.71 (18.0)	8.5 (216.0)	7.0 (177.8)	8	0.75 (19.1)	5/8 - 11 UNC	0.79 (20.0)	9.0 (229.0)	7.25 (184.2)	8	0.88 (22.2)	0.71 (18.0)	8.0 (203.0)	6.5 (165.1)	8	0.75 (19.1)
<b>4</b> (100)	0.71 (18.0)	9.0 (229.0)	7.5 (190.5)	8	0.75 (19.1)	5/8 - 11 UNC	0.79 (20.0)	10.0 (254.0)	7.88 (200.0)	8	0.88 (22.2)	0.71 (18.0)	8.5 (216.0)	7.0 (177.8)	8	0.75 (19.1)
<b>5</b> (125)	0.79 (20.0)	10.0 (254.0)	8.5 (215.9)	8	0.88 (22.2)	3/4 - 10 UNC	0.87 (22.0)	11.0 (279.0)	9.25 (235.0)	8	0.88 (22.2)	0.79 (20.0)	10.0 (254.0)	8.25 (209.6)	8	0.75 (19.1)
<b>6</b> (150)	0.87 (22.0)	11.0 (279.0)	9.5 (241.3)	8	0.88 (22.2)	3/4 - 10 UNC	0.87 (22.2)	12.5 (318.0)	10.62 (269.9)	12	0.88 (22.2)	0.87 (22.2)	11.0 (279.0)	9.25 (235.0)	8	0.88 (22.2)
<b>8</b> (200)	0.87 (22.0)	13.5 (343.0)	11.75 (298.5)	8	0.88 (22.2)	3/4 - 10 UNC	0.95 (24.0)	15.0 (381.0)	13.0 (330.2)	12	1.00 (25.4)	0.87 (22.2)	13.25 (337.0)	11.5 (292.1)	8	0.88 (22.2)
<b>10</b> (250)	0.95 (24.0)	16.0 (406.0)	14.25 (362.0)	12	1.00 (25.4)	7/8 - 9 UNC	1.02 (26.0)	17.5 (445.0)	15.25 (387.4)	16	1.13 (28.6)	0.95 (24.0)	16.0 (406.0)	14.0 (355.6)	12	0.88 (22.2)
<b>12</b> (300)	0.95 (24.0)	19.0 (483.0)	17.0 (431.8)	12	1.00 (25.4)	7/8 - 9 UNC	1.02 (26.0)	20.5 (521.0)	17.75 (450.9)	16	1.25 (31.8)	0.95 (24.0)	18.0 (457.0)	16.0 (406.4)	12	1.00 (25.4)
<b>14</b> (350)	1.02 (26.0)	21.0 (533.0)	18.75 (476.3)	12	1.13 (28.6)	1 - 8 UNC	1.10 (28.0)	23.0 (584.0)	20.25 (514.4)	20	1.25 (31.8)	1.02 (26.0)	20.75 (527.0)	18.5 (469.9)	12	1.00 (25.4)
<b>16</b> (400)	1.10 (28.0)	23.5 (597.0)	21.25 (539.8)	16	1.13 (28.6)	1 - 8 UNC	1.18 (30.0)	25.5 (648.0)	22.5 (571.5)	20	1.38 (34.9)	1.10 (28.0)	22.75 (578.0)	20.5 (520.7)	12	1.00 (25.4)
<b>18</b> (450)	1.18 (30.0)	25.0 (635.0)	22.75 (577.9)	16	1.25 (31.8)	1 1/8 - 7 UNC	1.18 (30.0)	28.0 (711.0)	24.75 (628.7)	24	1.38 (34.9)	1.18 (30.0)	25.25 (641.0)	23.0 (584.2)	16	1.00 (25.4)
<b>20</b> (500)	1.18 (30.0)	27.5 (699.0)	25.0 (635.0)	20	1.25 (31.8)	1 1/8 - 7 UNC	1.18 (30.0)	30.5 (775.0)	27.0 (685.8)	24	1.38 (34.9)	1.18 (30.0)	27.75 (705.0)	25.25 (641.4)	16	1.00 (25.4)
<b>24</b> (600)	1.18 (30.0)	32.06 (813.0)	29.5 (749.3)	20	1.38 (34.9)	1 1/4 - 7 UNC	1.18 (30.0)	36.0 (914.0)	32.0 (812.8)	24	1.62 (41.3)	1.18 (30.0)	32.5 (826.0)	29.75 (755.7)	16	1.25 (31.8)
<b>30</b> (750)	1.26 (32.0)	38.75 (984.0)	36.0 (914.4)	28	1.38 (34.9)	1 1/4 - 7 UNC	1.26 (32.0)	43.0 (1092.0)	39.25 (997.0)	28	2.00 (50.8)	1.26 (32.0)	39.25 (997.0)	36.5 (927.1)	20	1.38 (34.9)

**Table 4: Flange Drilling**

NOMINAL Pipe Size Inch (mm)	Metric Series Conforms to I.S.O. 2084-1974 Table PN10 Holes to I.S.O. /R-273					Metric Series Conforms to I.S.O. 2084-1974 Table PN16 Holes to I.S.O. /R-273					J.I.S. Standard B-2212 Conforms to J.I.S. 10Kg/cm				
	Flange Thickness	Flange O.D.	Bolt Circle	No. of Holes	Hole Size	Flange Thickness	Flange O.D.	Bolt Circle	No. of Holes	Hole Size	Flange Thickness	Flange O.D.	Bolt Circle	No. of Holes	Hole Size
<b>1</b> (25)	0.63 (16.0)	4.53 (115.0)	3.35 (85.0)	4	0.55 (14.0)	0.63 (16.0)	4.53 (115.0)	3.35 (85.0)	4	0.55 (14.0)	0.59 (15.0)	4.92 (125.0)	3.54 (90.0)	4	0.75 (19.0)
<b>1.25</b> (32)	0.63 (16.0)	5.51 (140.0)	3.94 (85.0)	4	0.71 (18.0)	0.63 (16.0)	5.51 (140.0)	3.94 (100.0)	4	0.71 (18.0)	0.59 (15.0)	5.31 (135.0)	3.94 (100.0)	4	0.75 (19.0)
<b>1.5</b> (40)	0.63 (16.0)	5.91 (150.0)	4.33 (110.0)	4	0.71 (18.0)	0.63 (16.0)	5.91 (150.0)	4.33 (110.0)	4	0.71 (18.0)	0.59 (15.0)	5.51 (140.0)	4.13 (105.0)	4	0.75 (19.0)
<b>2</b> (50)	0.71 (18.0)	6.50 (165.0)	4.92 (125.0)	4	0.71 (18.0)	0.71 (18.0)	6.50 (165.0)	4.92 (125.0)	4	0.71 (18.0)	0.63 (16.0)	6.10 (155.0)	4.72 (120.0)	4	0.75 (19.0)
<b>2.5</b> (65)	0.71 (18.0)	7.28 (185.0)	5.71 (145.0)	4	0.71 (18.0)	0.71 (18.0)	7.28 (185.0)	5.71 (145.0)	4	0.71 (18.0)	0.71 (18.0)	6.89 (175.0)	5.51 (140.0)	4	0.75 (19.0)
<b>3</b> (80)	0.79 (20.0)	7.87 (200.0)	6.3 (160.0)	8	0.71 (18.0)	0.79 (20.0)	7.87 (200.0)	6.30 (160.0)	8	0.71 (18.0)	0.71 (18.0)	7.28 (185.0)	5.91 (150.0)	8	0.75 (19.0)
<b>3.5</b> (90)	— —	— —	— —	— —	— —	— —	— —	— —	— —	— —	0.71 (18.0)	7.68 (195.0)	6.30 (160.0)	8	0.75 (19.0)
<b>4</b> (100)	0.79 (20.0)	8.66 (220.0)	7.09 (180.0)	8	0.71 (18.0)	0.79 (20.0)	8.66 (220.0)	7.09 (180.0)	8	0.71 (18.0)	0.71 (18.0)	8.27 (210.0)	6.89 (175.0)	8	0.75 (19.0)
<b>5</b> (125)	0.87 (22.0)	9.84 (250.0)	8.27 (210.0)	8	0.71 (18.0)	0.87 (22.0)	9.84 (250.0)	8.27 (210.0)	8	0.71 (18.0)	0.79 (20.0)	9.84 (250.0)	8.27 (210.0)	8	0.91 (23.0)
<b>6</b> (150)	0.87 (22.0)	11.22 (285.0)	9.45 (240.0)	8	0.87 (22.0)	0.87 (22.0)	11.22 (285.0)	9.45 (240.0)	8	0.87 (22.0)	0.87 (22.0)	11.02 (280.0)	9.45 (240.0)	8	0.91 (23.0)
<b>8</b> (200)	0.87 (22.0)	13.39 (340.0)	11.61 (295.0)	8	0.87 (22.0)	0.87 (22.0)	13.39 (340.0)	11.61 (295.0)	12	0.87 (22.0)	0.87 (22.0)	12.99 (330.0)	11.42 (290.0)	12	0.91 (23.0)
<b>10</b> (250)	1.02 (26.0)	15.55 (395.0)	13.78 (350.0)	12	0.87 (22.0)	1.02 (26.0)	15.94 (405.0)	13.98 (355.0)	12	1.02 (26.0)	0.95 (24.0)	15.75 (400.0)	13.98 (355.0)	12	0.98 (25.0)
<b>12</b> (300)	1.02 (26.0)	17.52 (445.0)	15.75 (400.0)	12	0.87 (22.0)	1.02 (26.0)	18.11 (460.0)	16.14 (410.0)	12	1.02 (26.0)	0.95 (24.0)	17.52 (445.0)	15.75 (400.0)	16	0.98 (25.0)
<b>14</b> (350)	1.10 (28.0)	19.88 (505.0)	18.11 (460.0)	16	0.87 (22.0)	1.10 (28.0)	20.47 (520.0)	18.50 (470.0)	16	1.02 (26.0)	1.02 (26.0)	19.29 (490.0)	17.52 (445.0)	16	0.98 (25.0)
<b>16</b> (400)	1.18 (30.0)	22.24 (565.0)	20.28 (515.0)	16	1.02 (26.0)	1.18 (30.0)	22.83 (580.0)	20.67 (525.0)	16	1.18 (30.0)	1.10 (28.0)	22.05 (560.0)	20.08 (510.0)	16	1.06 (27.0)
<b>18</b> (450)	1.18 (30.0)	24.21 (615.0)	22.24 (565.0)	20	1.02 (26.0)	1.18 (30.0)	25.20 (640.0)	23.03 (585.0)	20	1.18 (30.0)	1.18 (30.0)	24.41 (620.0)	22.24 (565.0)	20	1.06 (27.0)
<b>20</b> (500)	1.18 (30.0)	26.38 (670.0)	24.41 (620.0)	20	1.02 (26.0)	1.18 (30.0)	28.15 (715.0)	25.59 (650.0)	20	1.30 (33.0)	1.18 (30.0)	26.57 (675.0)	24.41 (620.0)	20	1.06 (27.0)
<b>24</b> (600)	1.18 (30.0)	30.71 (780.0)	28.54 (725.0)	20	1.18 (30.0)	1.18 (30.0)	33.07 (840.0)	30.31 (770.0)	20	1.42 (36.0)	1.18 (30.0)	31.30 (795.0)	28.74 (730.0)	24	1.30 (33.0)
<b>30</b> (750)	1.26 (32.0)	37.99 (965.0)	35.43 (900.0)	24	1.30 (33.0)	1.26 (32.0)	38.19 (970.0)	35.43 (900.0)	24	1.42 (36.0)	1.26 (32.0)	38.19 (970.0)	35.07 (900.0)	24	1.30 (33.0)

# Drilling Chart for Bolting Requirements

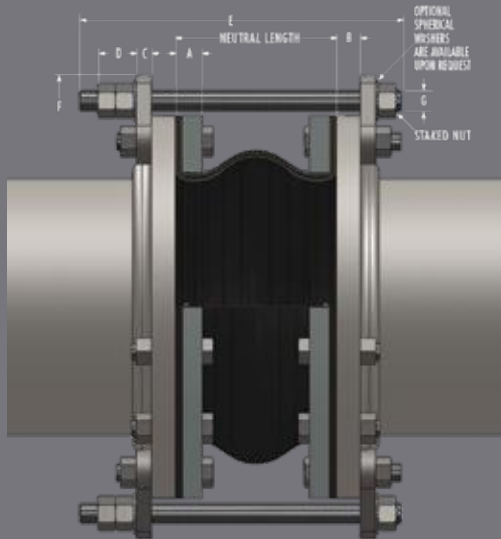
<b>Table 5:</b>		<b>Standard Drilling for PROCO Rubber Expansion Joints</b>				<b>Thickness of Materials for PROCO Rubber Expansion Joints</b>			<b>Control Unit Plate Detail</b>	
<b>Nominal Pipe Size Expansion Joint I.D. Inch / (mm)</b>	<b>Flange Dimensions <sup>2</sup></b>					<b>Material Thickness <sup>1</sup> for Bolt Length Requirements</b>				
	<b>Flange O.D. Inch / (mm)</b>	<b>Bolt Circle Inch / (mm)</b>	<b>Number Of Holes</b>	<b>Size Of Holes Inch / (mm)</b>	<b>Bolt Hole Thread</b>	<b>Nominal Flange/ Beaded End Thickness Inch / (mm) (Approx. Value)</b>	<b>Adjacent Mating <sup>3</sup> Flange Thickness</b>	<b>Max. Control <sup>4</sup> Rod Plate Thickness Inch / (mm)</b>		
<b>1</b> (25)	<b>4.25</b> (108.0)	<b>3.13</b> (79.50)	<b>4</b>	<b>0.625</b> (15.87)	<b>1/2-13 UNC</b>	<b>1.25</b> (31.75)	<b>CUSTOMER TO SPECIFY MATING FLANGE THICKNESS</b>	<b>0.375</b> (9.53)	<b>8.375</b> (215.9)	<b>0.625</b> (15.9)
<b>1.25</b> (32)	<b>4.63</b> (118.0)	<b>3.5</b> (88.90)	<b>4</b>	<b>0.625</b> (15.87)	<b>1/2-13 UNC</b>	<b>1.25</b> (31.75)		<b>0.375</b> (9.53)	<b>8.750</b> (222.3)	<b>0.625</b> (15.9)
<b>1.5</b> (40)	<b>5.0</b> (127.0)	<b>3.88</b> (98.55)	<b>4</b>	<b>0.625</b> (15.87)	<b>1/2-13 UNC</b>	<b>1.25</b> (31.75)		<b>0.375</b> (9.53)	<b>9.125</b> (231.8)	<b>0.625</b> (15.9)
<b>2</b> (50)	<b>6.00</b> (152.00)	<b>4.75</b> (120.65)	<b>4</b>	<b>0.750</b> (19.05)	<b>5/8-11 UNC</b>	<b>1.25</b> (31.75)		<b>0.375</b> (9.53)	<b>10.125</b> (257.2)	<b>0.625</b> (15.9)
<b>2.5</b> (65)	<b>7.00</b> (178.00)	<b>5.50</b> (139.70)	<b>4</b>	<b>0.750</b> (19.05)	<b>5/8-11 UNC</b>	<b>1.25</b> (31.75)		<b>0.375</b> (9.53)	<b>11.125</b> (282.6)	<b>0.625</b> (15.9)
<b>3</b> (80)	<b>7.50</b> (191.00)	<b>6.00</b> (152.40)	<b>4</b>	<b>0.750</b> (19.05)	<b>5/8-11 UNC</b>	<b>1.25</b> (31.75)		<b>0.375</b> (9.53)	<b>11.625</b> (295.3)	<b>0.625</b> (15.9)
<b>3.5</b> (90)	<b>8.5</b> (216.0)	<b>7.0</b> (177.80)	<b>8</b>	<b>0.750</b> (19.05)	<b>5/8-11 UNC</b>	<b>1.25</b> (31.75)		<b>0.375</b> (9.53)	<b>12.625</b> (320.7)	<b>0.625</b> (15.9)
<b>4</b> (100)	<b>9.00</b> (229.00)	<b>7.50</b> (190.50)	<b>8</b>	<b>0.750</b> (19.05)	<b>5/8-11 UNC</b>	<b>1.25</b> (31.75)		<b>0.375</b> (9.53)	<b>13.125</b> (333.4)	<b>0.625</b> (15.9)
<b>5</b> (125)	<b>10.00</b> (254.00)	<b>8.50</b> (215.90)	<b>8</b>	<b>0.875</b> (22.23)	<b>3/4-10 UNC</b>	<b>1.50</b> (38.10)		<b>0.500</b> (12.70)	<b>14.125</b> (358.8)	<b>0.625</b> (15.9)
<b>6</b> (150)	<b>11.00</b> (279.00)	<b>9.50</b> (241.30)	<b>8</b>	<b>0.875</b> (22.23)	<b>3/4-10 UNC</b>	<b>1.50</b> (38.10)		<b>0.500</b> (12.70)	<b>15.125</b> (384.2)	<b>0.625</b> (15.9)
<b>8</b> (200)	<b>13.50</b> (343.00)	<b>11.75</b> (298.45)	<b>8</b>	<b>0.875</b> (22.23)	<b>3/4-10 UNC</b>	<b>1.50</b> (38.10)		<b>0.750</b> (19.05)	<b>19.125</b> (485.8)	<b>1.000</b> (25.4)
<b>10</b> (250)	<b>16.00</b> (406.00)	<b>14.25</b> (361.95)	<b>12</b>	<b>1.000</b> (25.40)	<b>7/8-9 UNC</b>	<b>1.50</b> (38.10)		<b>0.750</b> (19.05)	<b>21.625</b> (549.3)	<b>1.000</b> (25.4)
<b>12</b> (300)	<b>19.00</b> (483.00)	<b>17.00</b> (431.80)	<b>12</b>	<b>1.000</b> (25.40)	<b>7/8-9 UNC</b>	<b>1.50</b> (38.10)		<b>0.750</b> (19.05)	<b>24.625</b> (625.5)	<b>1.000</b> (25.4)
<b>14</b> (350)	<b>21.00</b> (533.00)	<b>18.75</b> (476.25)	<b>12</b>	<b>1.125</b> (28.58)	—	<b>1.75</b> (44.45)		<b>0.750</b> (19.05)	<b>26.625</b> (676.3)	<b>1.000</b> (25.4)
<b>16</b> (400)	<b>23.50</b> (597.00)	<b>21.25</b> (539.75)	<b>16</b>	<b>1.125</b> (28.58)	—	<b>1.75</b> (44.45)		<b>0.750</b> (19.05)	<b>30.125</b> (765.2)	<b>1.250</b> (31.8)
<b>18</b> (450)	<b>25.00</b> (635.00)	<b>22.75</b> (577.85)	<b>16</b>	<b>1.250</b> (31.75)	—	<b>2.00</b> (50.80)		<b>0.750</b> (19.05)	<b>31.625</b> (803.3)	<b>1.250</b> (31.8)
<b>20</b> (500)	<b>27.50</b> (699.00)	<b>25.00</b> (635.00)	<b>20</b>	<b>1.250</b> (31.75)	—	<b>2.00</b> (50.80)		<b>0.750</b> (19.05)	<b>34.125</b> (866.8)	<b>1.250</b> (31.8)
<b>24</b> (600)	<b>32.00</b> (813.00)	<b>29.50</b> (749.30)	<b>20</b>	<b>1.375</b> (34.93)	—	<b>2.00</b> (50.80)		<b>1.000</b> (25.40)	<b>38.625</b> (981.1)	<b>1.250</b> (31.8)
<b>30</b> (750)	<b>38.75</b> (984.00)	<b>36.00</b> (914.40)	<b>28</b>	<b>1.375</b> (34.93)	—	<b>2.00</b> (50.80)		<b>1.250</b> (31.75)	<b>46.375</b> (1177.0)	<b>1.500</b> (38.1)

Metric Conversion Formula:  
Nominal I.D.:  
in. x 25 = mm; Dimensions/  
Thickness': in. x 25.4 = mm.

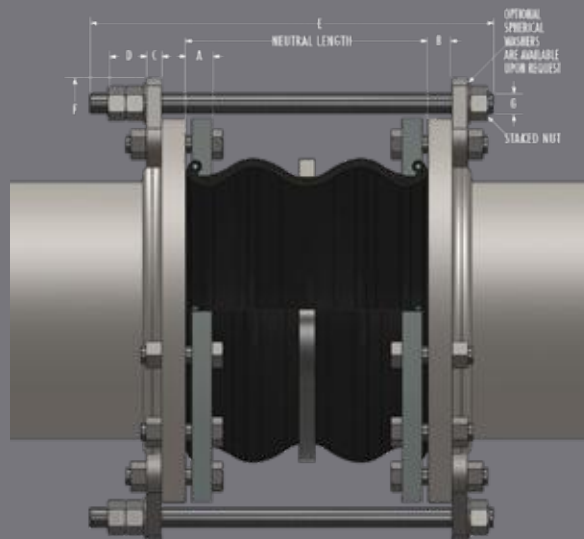
- Notes:**
1. Limit/Control Rod length is determined by neutral length of rubber expansion joint, rated extension, control rod plate thickness, mating flange thickness and number of nuts. Consult PROCO for rod lengths.
  2. Flange Dimensions shown are in accordance with ANSI B16.1 and ANSI B16.5 Class 125/150, AWWA C-207-07, Tbl 2 and 3 - Class D, Table 4 - Class E. Hole size shown is 1/8" larger than AWWA Standard.
  3. Adjacent mating flange thickness is required to determine overall rod length and compression sleeve length (if required).
  4. Plate thickness is based on a maximum width PROCO would use to design a Limit/Control Rod plate.
  5. Flat Washers required at ring splits and are supplied by others.
  6. Control rod plate O.D. installed dimension is based on a maximum O.D. Proco would supply.
  7. Control rod diameter is based on a maximum diameter Proco would use to design a control

- A** - Flange/Beaded End Thickness (Approximated Figure)
- B** - Adjacent Mating Flange Thickness (By Others)
- C** - Control Unit Plate Thickness
- D** - Double Nut Thickness is determined by Control Rod Diameter

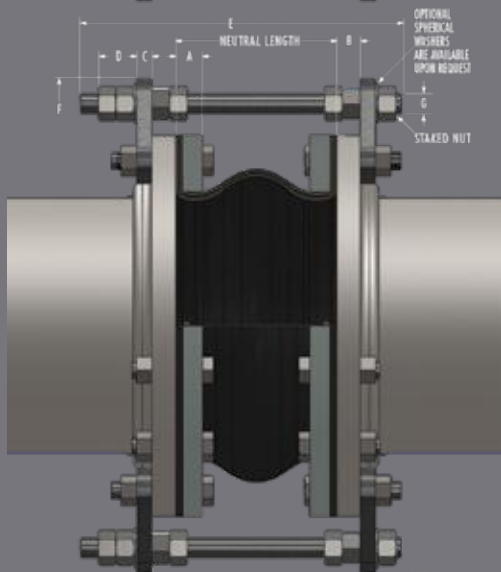
- E** - Control Rod Bolt Length is determined by A through E + OAL <sup>1</sup>
- F** - Control Rod Control Rod Plate O.D.
- G** - Maximum Rod Diameter



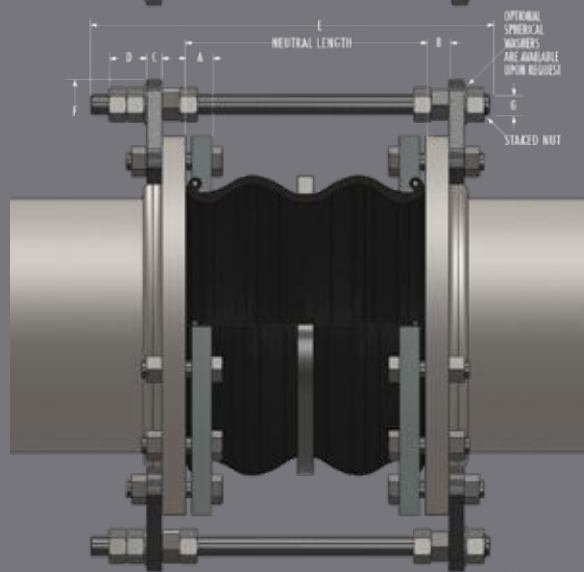
**Figure 1**  
Style 240



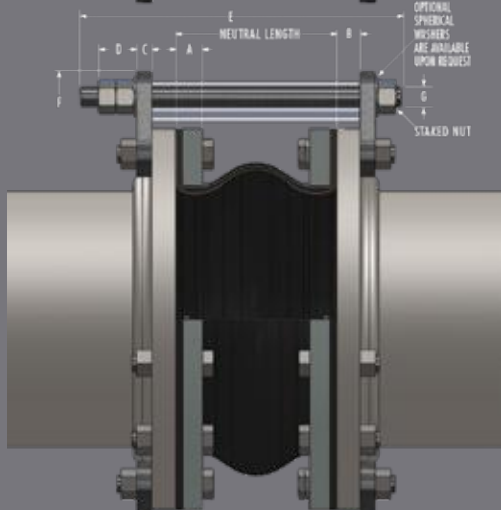
**Figure 1**  
Style 242



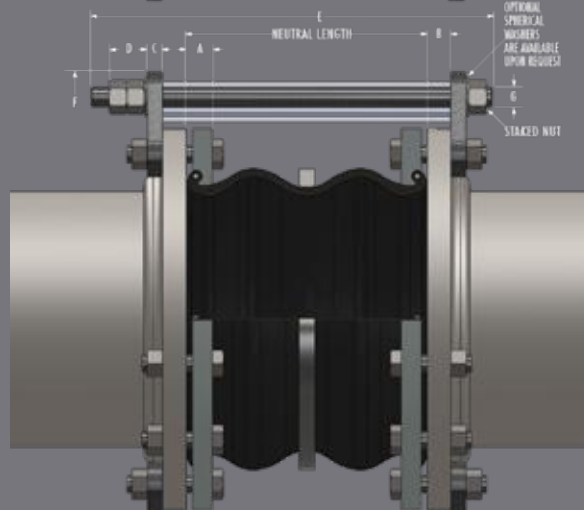
**Figure 2**  
Style 240



**Figure 2**  
Style 242



**Figure 3**  
Style 240



**Figure 3**  
Style 242

# Limit Rods

## Use of Control Units with Rubber Expansion Joints

### Definition

A control unit assembly is a system of two or more control rod units (limit rods, tie rods or compression sleeves) placed across an expansion joint from flange to flange to minimize possible damage caused by excessive motion of a pipeline. The control unit assemblies can be set at the maximum allowable expansion and/or contraction of the rubber expansion joint. When used in this manner, control units are an additional safety factor and can minimize possible damage to adjacent equipment.

Rubber expansion joints should be installed between two fixed anchor points in a piping system. The pipe system must be rigidly anchored on both sides of the expansion joint to control expansion or contraction of the line. Piping anchors must be capable of withstanding the line thrusts generated by internal pressure or wide temperature fluctuations.

When proper anchoring cannot be provided, **CONTROL UNITS ARE REQUIRED.** For un-anchored piping systems nuts shall be tightened snug against rod plate to prevent over-extension due to pressure thrust created by expansion joint. Refer to "Thrust Factor" in Table 2, note 5 in this manual. Please also see Table 7 for number of control rods recommended based on maximum surge for test pressure of the system

Listed below are three (3) control unit configurations supplied by PROCO and are commonly used with rubber expansion joints in piping systems.

### Figure 1

Known as a **LIMIT ROD**, this control unit configuration will allow an expansion joint to extend to a predetermined extension setting. Nuts shall be field-set to no more than the maximum allowable extension movement of a rubber expansion joint (unless used in an un-anchored system). Refer to Table 2 in this manual for allowable movement capabilities. Spherical washers can also be furnished (upon request) to combat any "nut-to-plate" binding during offset. **Consult the systems engineer for proper nut settings prior to system operation.**

### Figure 2

Known as a **LIMIT/CONTROL ROD**, this control unit configuration is used to allow specified pipe expansion (expansion joint axial compression) and pipe contraction (expansion joint axial extension) movements. Nuts shall be field set to no more than the maximum allowable extension (unless used in an un-anchored pipe system) or compression of a rubber expansion joint. Refer to Table 2 in this manual for allowable movement capabilities. Internal and external nuts can also be field-set to allow for no movement in the horizontal plane. This setting will allow the rubber to move laterally while keeping expansion joint thrust forces low on adjacent equipment. Spherical washers can also be furnished (upon request) to combat any potential "nut-to-plate" binding during offset. **Limit/Control rods with internal nuts must be specified at the time of inquiry. Consult the systems engineer for proper nut settings prior to system operation.**

### Figure 3

Known as a **COMPRESSION SLEEVE**, this configuration is used to allow for specified pipe expansion (expansion joint axial compression) and pipe contraction (expansion joint extension) movements. Nuts shall be field-set to no more than the maximum allowable extension (unless used in an un-anchored pipe system) of a rubber expansion joint. Refer to Table 2 in this manual for allowable movement capabilities. PROCO will manufacture each compression sleeve to allow for no axial movement unless otherwise specified by the purchaser. Compression sleeves shall be field-trimmed to meet required allowable axial movement as set forth by system requirements. Spherical washers can also be furnished (upon request) to combat any potential "nut-to-plate" binding during offset. **Consult the systems engineer for proper sleeve lengths prior to system operation.**

### Important Control Unit Considerations

The number of rods, control rod diameters and control rod plate thicknesses are important considerations when specifying control units for an application. As a minimum, specifying engineers or purchasers shall follow the guidelines as set forth in Appendix C of the Fluid Sealing Association's Technical Handbook, Seventh Edition. PROCO engineers its control unit assemblies to system requirements. Our designs incorporate an allowable stress of 65% of material yield for each rod and plate (rod and plate material to be specified by purchaser). Therefore, it is important to provide pressure and temperature ratings to

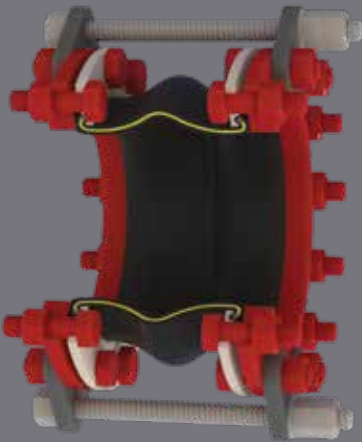
## Installation Instructions for Limit Rods

1. Assemble expansion joint between pipe flanges in its manufactured face-to-face length.
2. Assemble control rod plates behind pipe flanges as shown. Flange bolts or all-thread studs through the control rod plate must be longer to accommodate the plate thickness. Control rod plates should be equally spaced around the flange. Depending upon the size and pressure rating of the system, 2, 3, 4, or more control/limit rods may be required. Refer to Table 4 in this manual or to the Fluid Sealing Association's Technical Handbook, Seventh Edition, for control rod pressure ratings.
3. Insert control/limit rods through top plate holes. Steel flat washers are to be positioned at outer plate surface.
4. If a single nut per unit is furnished, position this nut so that there is a gap between the nut and the steel flat washer. This gap is equal to the joint's maximum extension (commencing with the nominal face-to-face length). To lock this nut in position, either "stake" the thread in two places or tack weld the nut to the rod. If two nuts are supplied, the nuts will create a "jamming" effect to prevent loosening. (Nuts should be snug against the flat washer and control rod plate when piping system is un-anchored.)

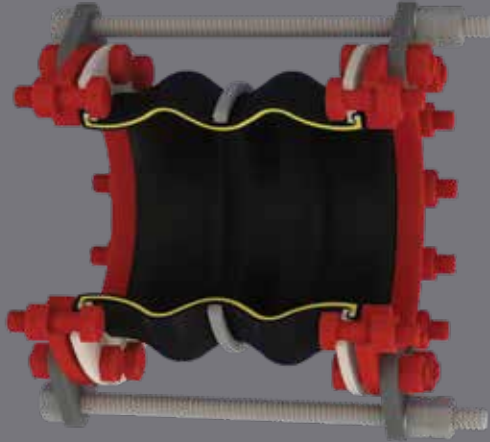
*Note: Consult the manufacturer if there are any questions as to the rated compression and elongation. These two dimensions are critical in setting the nuts and sizing the compression pipe sleeve (if supplied).*

5. If there is a requirement for compression pipe sleeves, an ordinary pipe may be used, sized in length to allow the joint to be compressed to its normal limit.
6. If there is a requirement for optional spherical washers,

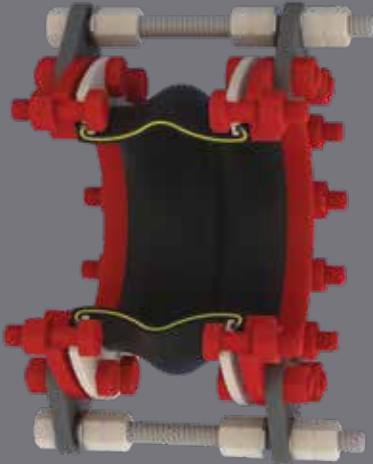
**Figure 1**  
Style 240



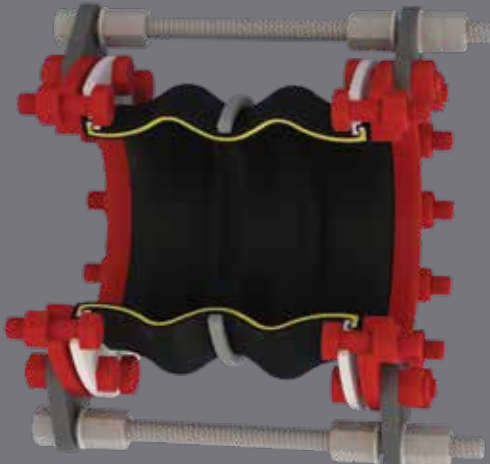
**Figure 1**  
Style 242



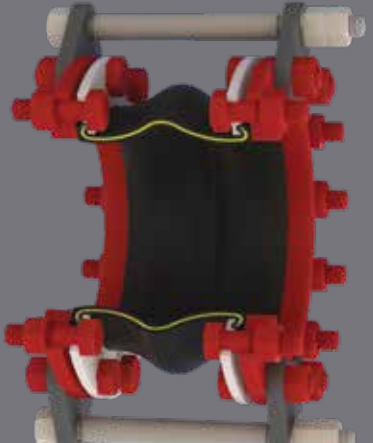
**Figure 2**  
Style 240



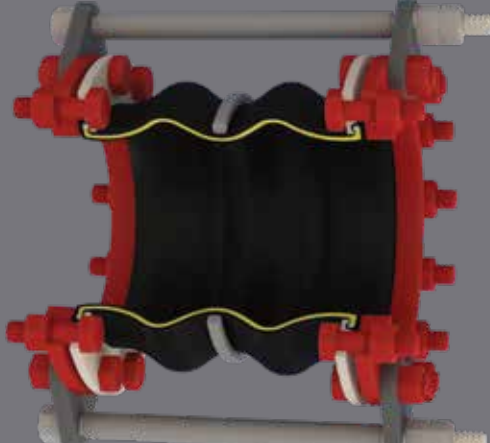
**Figure 2**  
Style 242



**Figure 3**  
Style 240



**Figure 3**  
Style 242



**Table 6:**  
**Control Units/Anchored**

Control Units must be installed when pressures (test • design • surge • operating) exceed rating below:

Pipe Size	Series 240 P.S.I.G.	Series 242 P.S.I.G.
1" thru 4"	180	135
5" thru 10"	135	135
12" thru 14"	90	90
16" thru 24"	45	45
30"	35	35

**Table 7:** Maximum Surge or Test Pressure of the System

Nominal Pipe Size Expansion Joint I.D. Inch / (mm)	Number of Control Rods Recommended			
	2	4	6	8
1 (25)	949	•	•	•
1.25 (32)	830	•	•	•
1.5 (40)	510	•	•	•
2 (50)	661	•	•	•
2.5 (65)	529	•	•	•
3 (75)	441	•	•	•
4 (100)	311	622	•	•
5 (125)	235	470	•	•
6 (150)	186	371	•	•
8 (200)	163	326	•	•
10 (250)	163	325	488	•
12 (300)	160	320	481	•
14 (350)	112	223	335	•
16 (400)	113	227	340	453
18 (450)	94	187	281	375
20 (500)	79	158	236	315
24 (600)	74	147	221	294
30 (750)	70	141	211	281

Note:  
Pressures listed above do not relate to the actual design pressure of the expansion joint products, but are the maximum surge or pressure for a specific control rod nominal pipe size.

# Installation Instructions for Non-Metallic Expansion

## 1. Service Conditions:

Make sure the expansion joint rating for temperature, pressure, vacuum\*, movements and selection of elastomeric materials match the system requirements. Contact the manufacturer if the system requirements exceed those of the expansion joint selected. (\*Vacuum service for spherical rubber connectors: Vacuum rating is based on neutral installed length. These products should not be installed "extended" on vacuum applications.)

## 2. Alignment:

Expansion joints are not designed to make up for piping misalignment errors. Piping misalignment should be no more than 1/8" in any direction. Misalignment of an expansion joint will reduce the rated movements and can induce severe stress of the material properties, thus causing reduced service life or premature failure.

## 3. Anchoring:

Expansion joints should be located as close as possible to anchor points with proper pipe guides. Install expansion joints only on straight runs between anchors. It is recommended that control rods be installed on the expansion joint to prevent excessive movements from occurring due to pressure thrust of the line.

## 4. Pipe Support:

Piping must be supported so expansion joints do not carry any pipe weight.

## 5. Mating Flanges:

Install the expansion joint against the mating pipe flanges and install bolts so that the bolt head is against the expansion joint flange. Flange-to-flange dimension of the expansion joint must match the breech opening\*. (\*A spherical rubber connector must be pre-compressed 1/8" to 3/16" during installation in order to obtain a correct installed face-to-face dimension.)

Make sure the mating flanges are clean and are a flat-faced type. When attaching beaded end flange expansion joints to raised face flanges, the use of composite gaskets are required to prevent metal flange faces from cutting rubber bead during installation.

Never install expansion joints next to wafer type check or butterfly valves.

## 6. Bolting Torque:

Table 8 shows the recommended torque values for non-metallic expansion joints with beaded end type-flanges: Tighten bolts in stages by alternating around the flange. Use the recommended torque values in Table 8 to achieve a good seal. Never tighten an expansion joint to the point that there is metal-to-metal contact between the expansion joint flanges and the mating flanges. A slight bulge in the rubber beaded end should create a flush tight seal.

*Note: Torque values are approximate due to mating flange surfaces, installation offsets, operating pressures and environmental conditions.*

## 7. Storage:

Ideal storage is in a warehouse with a relatively dry, cool location. Store flanges face down on a pallet or wooden platform. Do not store other heavy items on top of the expansion joints. Ten year shelf life can be expected with ideal conditions. If storage must be outdoors, place on a wooden platform and joints should not be in contact with the ground. Cover with a tarpaulin.

## 8. Large Joint Handling:

Do not lift with ropes or bars through the bolt holes. If lifting through the bore, use padding or a saddle to distribute the weight. Make sure cables or forklift tines do not contact the rubber. Do not let expansion joints sit vertically on the edges of the flanges for any period of time.

## 9. Additional Tips:

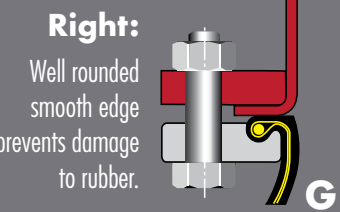
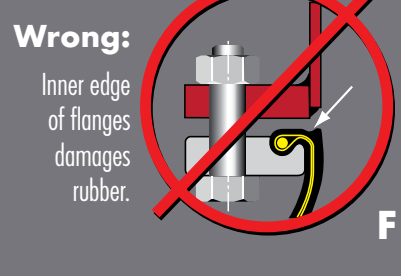
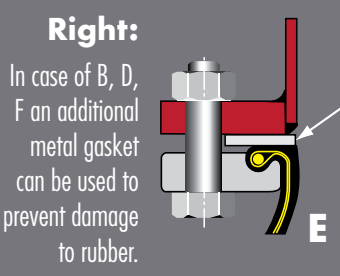
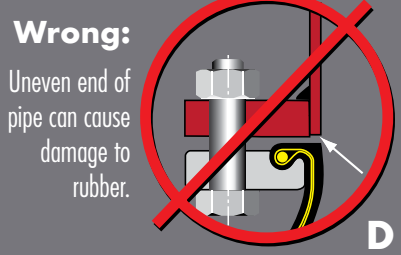
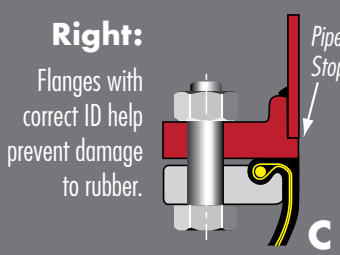
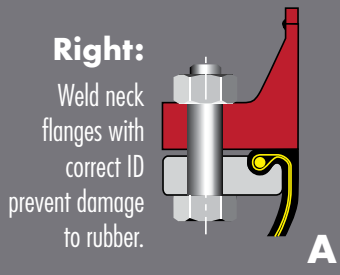
- A. Do not insulate/cover over a rubber expansion joint. This prevents inspection of the tightness of the joint bolting.
- B. It is acceptable (but not necessary) to lubricate the expansion joint beaded end with a thin film of graphite dispersed in glycerin or water at time of installation to prevent damage.
- C. Do not weld in the near vicinity of a non-metallic joint.
- D. If expansion joints are to be installed underground, or will be submerged in water, contact manufacturer for specific recommendations.
- E. If the expansion joint will be installed outdoors, make sure the cover material will withstand ozone, sunlight, etc.
- F. Check the tightness of flanges two or three weeks after installation and retighten if necessary. Refer to Notes in Para 6. Bolting Torque.
- G. Expansion joint installation should be conducted by an authorized and qualified pipe fitter.
- H. While all Proco expansion joints are guaranteed for a period of one year and designed for many years of service, it is suggested that expansion joints be routinely inspected based on service conditions.

*Warning: Expansion joints may operate in pipelines or equipment carrying fluids and/or gasses at elevated temperature and pressures and may transport hazardous materials. Precautions should be taken to protect personnel in the event of leakage or splash. Rubber joints should not be installed in areas where inspection is*

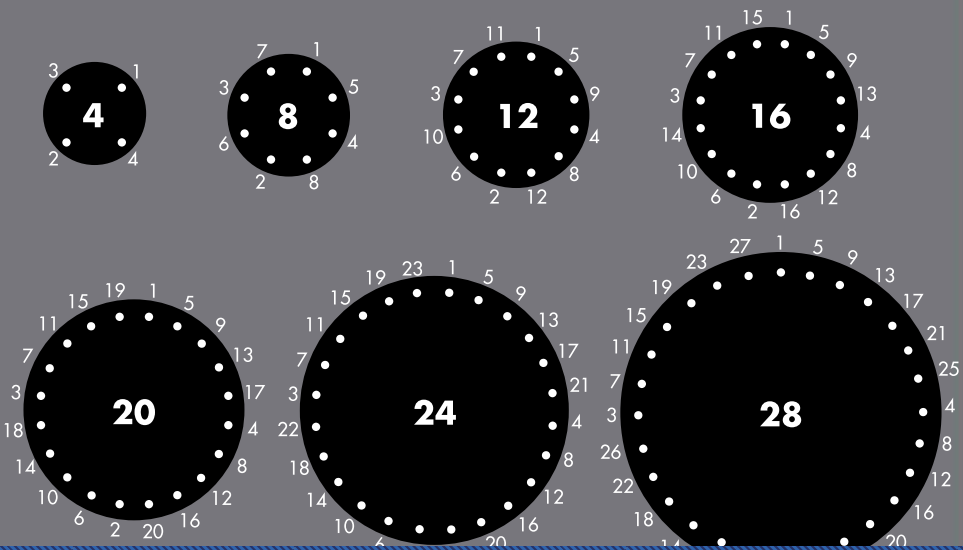
# Joists with Beaded End Flanges

Nominal Pipe Size Expansion Joint I.D. Inch / (mm)	Bolt-Torque				
	Step 1 FT-LBS (Nm)	Rest	Step 2 FT-LBS (Nm)	Rest	Step 3 FT-LBS (Nm)
<b>1</b> (25)	<b>18</b> (25)	<b>30</b> Min	<b>30</b> (40)	<b>60</b> Min	<b>45-60</b> (60-80)
<b>1.25</b> (32)	<b>18</b> (25)	<b>30</b> Min	<b>30</b> (40)	<b>60</b> Min	<b>45-60</b> (60-80)
<b>1.5</b> (40)	<b>18</b> (25)	<b>30</b> Min	<b>30</b> (40)	<b>60</b> Min	<b>45-60</b> (60-80)
<b>2</b> (50)	<b>18</b> (25)	<b>30</b> Min	<b>30</b> (40)	<b>60</b> Min	<b>45-60</b> (60-80)
<b>2.5</b> (65)	<b>18</b> (25)	<b>30</b> Min	<b>35</b> (50)	<b>60</b> Min	<b>50-60</b> (70-80)
<b>3</b> (80)	<b>25</b> (35)	<b>30</b> Min	<b>45</b> (60)	<b>60</b> Min	<b>60-75</b> (80-100)
<b>3.5</b> (90)	<b>25</b> (35)	<b>30</b> Min	<b>45</b> (60)	<b>60</b> Min	<b>60-75</b> (80-100)
<b>4</b> (100)	<b>25</b> (35)	<b>30</b> Min	<b>45</b> (60)	<b>60</b> Min	<b>60-75</b> (80-100)
<b>5</b> (125)	<b>25</b> (35)	<b>30</b> Min	<b>45</b> (60)	<b>60</b> Min	<b>60-75</b> (80-100)
<b>6</b> (150)	<b>30</b> (40)	<b>30</b> Min	<b>50</b> (70)	<b>60</b> Min	<b>60-75</b> (80-100)
<b>8</b> (200)	<b>30</b> (40)	<b>30</b> Min	<b>50</b> (70)	<b>60</b> Min	<b>60-75</b> (80-100)
<b>10</b> (250)	<b>30</b> (40)	<b>30</b> Min	<b>50</b> (70)	<b>60</b> Min	<b>75-85</b> (100-115)
<b>12</b> (300)	<b>30</b> (40)	<b>30</b> Min	<b>50</b> (70)	<b>60</b> Min	<b>75-85</b> (100-115)
<b>14</b> (350)	<b>30</b> (40)	<b>30</b> Min	<b>60</b> (80)	<b>60</b> Min	<b>75-95</b> (110-130)
<b>16</b> (400)	<b>30</b> (40)	<b>30</b> Min	<b>60</b> (80)	<b>60</b> Min	<b>75-95</b> (110-130)
<b>18</b> (450)	<b>30</b> (40)	<b>30</b> Min	<b>60</b> (80)	<b>60</b> Min	<b>90-95</b> (120-130)
<b>20</b> (500)	<b>30</b> (40)	<b>30</b> Min	<b>65</b> (90)	<b>60</b> Min	<b>95-185</b> (130-250)
<b>24</b> (600)	<b>30</b> (40)	<b>30</b> Min	<b>65</b> (90)	<b>60</b> Min	<b>95-185</b> (130-250)
<b>30</b> (750)	<b>30</b> (40)	<b>30</b> Min	<b>65</b> (90)	<b>60</b> Min	<b>95-220</b> (130-300)

Note: Bolt torque based on new bolts and nuts



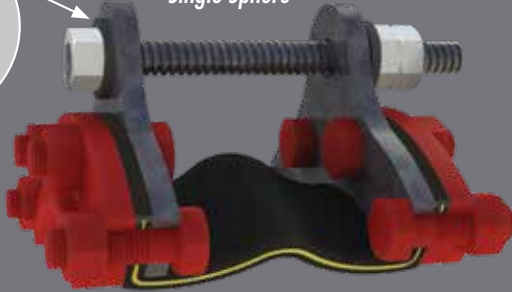
Tighten opposing nuts/bolts gradually according to the following sequence





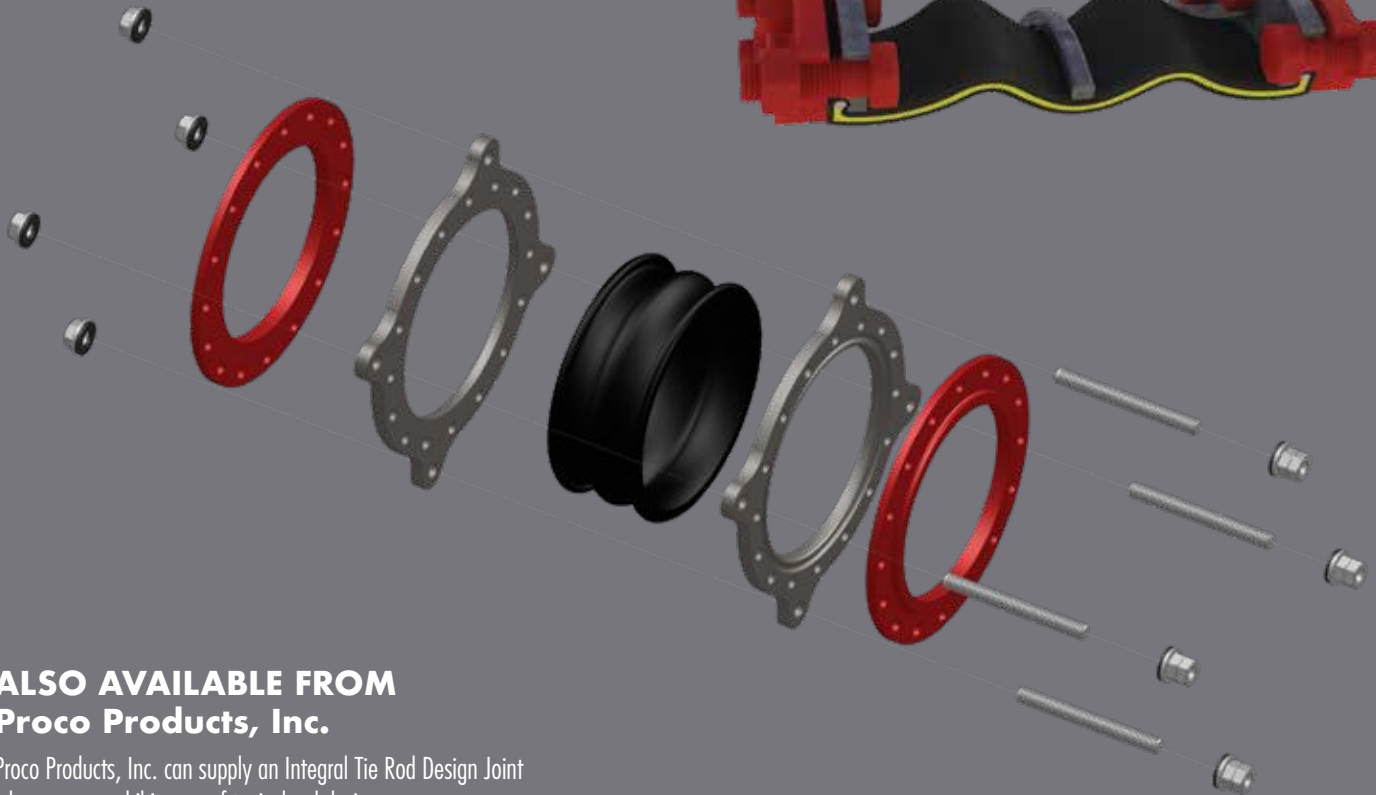
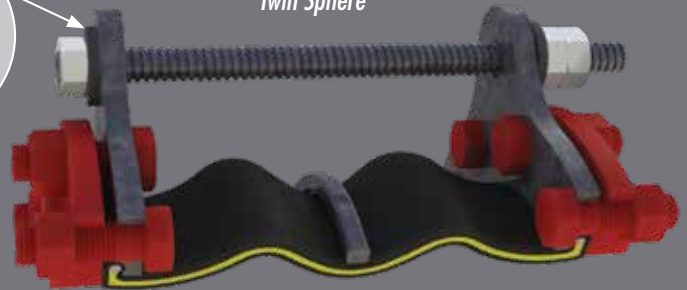
240-ITR  
Single Sphere

Optional  
Spherical Washers



Optional  
Spherical Washers

242-ITR  
Twin Sphere



**ALSO AVAILABLE FROM  
Proco Products, Inc.**

Proco Products, Inc. can supply an Integral Tie Rod Design Joint when space prohibits use of typical rod designs.



2431 North Wigwam Dr. (95205)  
P.O. Box 590 • Stockton, CA  
95201-0590 • USA

Toll-Free Phone: (800) 344-3246

Facsimile: (209) 943-0242

(209) 943-6088

email: sales@procoproducts.com

**NATIONWIDE AND CANADA**

**INTERNATIONAL**



Industrial Distributor Co-op



**REPRESENTED BY:**

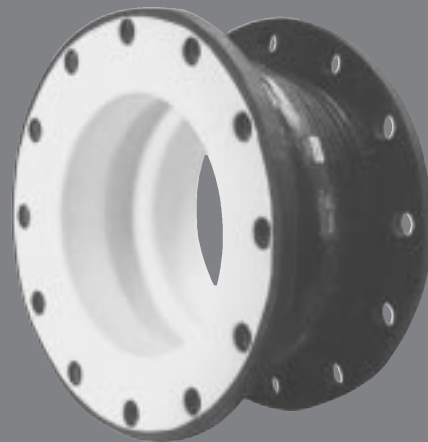
**GOODYEAR**  
RUBBER PRODUCTS, INC.

**727-342-5088**

You can also email us at  
**GRP@goodyearrubberproducts.com**

# PROCO™

## SERIES 251/BT



### PTFE and FEP lined rubber expansion joints

The PROCO Series 251/BT PTFE and FEP lined expansion joints are designed for tough demanding corrosive chemical applications, as found in: Chemical & Petrochemical Process Facilities and Highly Corrosive Industrial Piping & Pollution Control Systems. The greatest usage of the Series 251/BT is found in the Pulp and Paper Industry where the ability to resist corrosive attack at elevated temperature and pressure is unmatched by metallic, plastic or other competitive expansion joints. PROCO's Series 251 PTFE or FEP lined expansion joints can easily handle such pulp/paper applications as: White-Green-Black liquor, bleach plant chlorination and caustic extraction stages. Chemically resistant against the entire pH range, PROCO Series 251 PTFE and FEP expansion joints are designed to handle practically every chemical plant application. Installed next to mechanical equipment or between anchor points of a piping system, specify the PROCO 251/BT to: (1) Absorb Pipe Movements/Stress, (2) Reduce System Noise, (3) Isolate Mechanical Vibrations, (4) Compensate Alignment/Offset, (5) Eliminate Electrolytic Action and Electrolysis, (6) Protect Against Start-Up/Surge Forces. Our history in the manufacture of expansion joints dates back to 1930. When you need an engineered rubber expansion joint solution to a piping problem, call PROCO.

**Series 251/BT replaces Series FEP.** The new and improved PROCO Series 251/BT will replace the PROCO Series FEP lined rubber expansion joint. (Series FEP products will be available in certain sizes. Contact Proco for information.) This new hand-built product has been completely re-engineered to provide improved strength, flexibility and movement capabilities. Manufactured utilizing tire cord industry technology, the Series 251/BT combines woven polyester fabric and polyester tire cord into a fabric matrix and bonded with a Chlorobutyl elastomer that is reinforced with wire and bonded to a PTFE or FEP liner to create a product with greater operating performance.

**Greater Movements with a Lower/Wider Arch Profile.** The movements for the PROCO Series 251/BT exceed the specification of the Fluid Sealing Association's, Rubber Expansion Joint Division Technical Handbook (Sixth Edition), Table V. Due to a new and improved lower, wider profile arch, more axial compression and extension coupled with lateral and angular movements can be obtained without increasing the face-to-face requirements. For greater movements based on re-engineering and new product construction for highly corrosive piping installations, specify the PROCO Series 251/BT PTFE and FEP lined expansion joints.

**Chemical Service Capability at Minimal Cost.** Expensive, exotic metal expansion joint for low temperature service can be replaced with the PROCO Series 251/BT PTFE and FEP lined expansion joints. Engineered to operate up to 225 PSIG and 250°F, the PROCO Series 251/BT can be specified for a wide range of piping system requirements. Our standard stock is furnished with an exterior Chlorobutyl cover. Other elastomer covers are available on special order. Compared to metal, plastic or other rubber-backed competitive products, you will invest less and have access to in-stock availability with the high quality PROCO Series 251/BT.

**Specifications Met.** PROCO has assigned conservative pressure ratings to the Series 251/BT and FEP lined rubber expansion joints. The ratings, however, meet the requirements of the Fluid Sealing Association's, Rubber Expansion Joint Division Technical Handbook (Sixth Edition), Series C. The pressure ratings for the Series 251/BT PTFE and FEP lined rubber expansion joints have been fully tested and are based on a minimum four-to-one safety factor. For pressure protection with confidence, specify the PROCO Series 251/BT.

**Prevents Electrolysis and Electrolytic Action.** In Chemical applications when metallic expansion joints are used, they are generally of a metal dissimilar from the pipeline. This may create an electrolytic galvanic action that could be destructive to the connector equipment or piping system. The use of the rubber-backed PROCO 251/BT PTFE and FEP lined expansion joints prevents this potential hazard. Additionally, our 251/BT expansion joints are non-conductive and eliminate the metal-to-metal contact at the flange face thus stopping electrolysis.

**Absorbs Vibration • Noise • Shock.** The PROCO Series 251/BT PTFE and FEP lined rubber expansion joints are a replacement for "sound transmitting" metallic expansion joints. Sound loses energy traveling axially through an expansion joint. Water hammer, pumping impulses, water-borne noises and other forms of strain-stress-shock are cushioned and absorbed by the PTFE or FEP lined/rubber elastomer expansion joint, not related to piping. Install the Series 251/BT in a system to reduce vibration transmission when the piping section beyond the expansion joint is anchored or sufficiently rigid. For quiet, stress-free systems specify the PROCO Series 251/BT.

**Large Inventories Mean Same-Day Shipment.** We maintain the largest inventory of expansion joints in the world. Rubber, PTFE or FEP Lined, Plastic or Metal Hose — PROCO can ship the products you need when you need them! In fact, when it comes to expansion joints, **if PROCO doesn't have them in stock ... nobody does!**

**Information • Ordering • Pricing • Delivery.** Day or night, weekends and holidays ... the PROCO phones are monitored 24 hours around the clock. When you have a question, you can call us.

Toll-Free Phone ..... 800 / 344-3246 USA/CANADA

International Calls ..... 209 / 943-6088

Fax ..... 209 / 943-0242

Email ..... sales@procoproducts.com

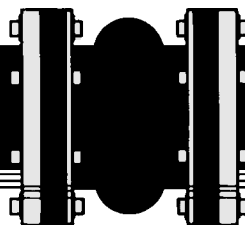
Website ..... www.procoproducts.com

Weekday office hours are 5:30 a.m. to 5:15 p.m. Pacific Time.

Table 1: Available Styles • Design Descriptions • I.D. Sizes

#251/BT — Standard Single-Arch, Spool-Type Joint (See Table 2)	1"-48"
#151 — Special Non-Standard Length Single-Arch, Spool-Type Joint	1"-48"
#152 — Special Non-Standard Double-Arch, Spool-Type Joint	1"-48"
#153 — Special Non-Standard Triple-Arch, Spool-Type Joint	1"-48"
#310 — Standard "No-Arch" Flanged Rubber Pipe Connectors	1"-12"

Rev. 01 11/00



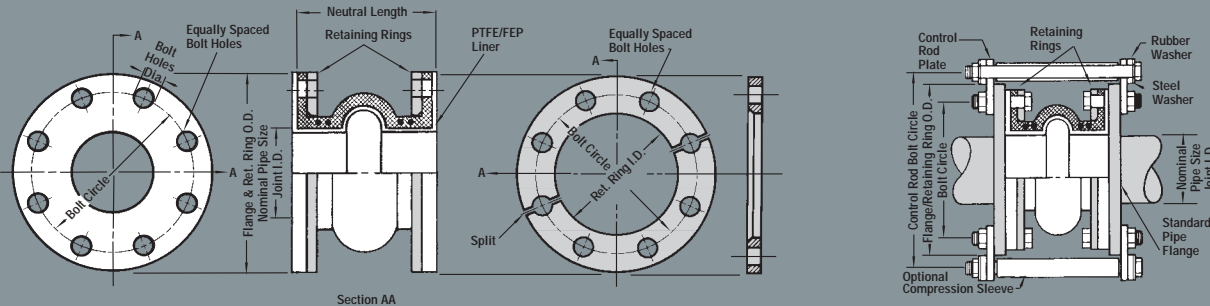
**Protecting Piping And  
Equipment Systems  
From Stress/Motion**

**GOODYEAR**  
RUBBER PRODUCTS, INC.

727-342-5088

You can also email us at  
[GRP@goodyearrubberproducts.com](mailto:GRP@goodyearrubberproducts.com)

# PTFE & FEP lined rubber expansion joints Figure 1: Detail Of Style 251/BT



**Table 2: Sizes • Movements • Pressures • Weights • Drilling**

EXPANSION JOINT SIZE Nom. I.D. x Inch / (mm)	NEUTRAL LENGTH Inch / (mm)		251/BT Movement Capability: From Neutral Position					Operating Conditions <sup>4</sup>		Weights in lbs / (kgs) <sup>5</sup>			Flange Dimensions and Drilling <sup>7</sup>					
			Axial Compression Inch / (mm)	Axial Extension Inch / (mm)	Lateral Deflection Inch / (mm)	Angular <sup>1</sup> Deflection Degrees	Torsional <sup>2</sup> Rotation Degrees	Thrust Factor <sup>3</sup> In <sup>2</sup> / (cm <sup>2</sup> )	Positive PSIG / (Bar)	Vacuum Inches of Hg / (mm of Hg)	Joint Assembly	Retaining Ring Set	Control Unit <sup>6</sup> Assembly	O.D. of Exp. Joint / Ring Inch / (mm)	Bolt Circle Inch / (mm)	Number of Holes	Size of Holes Inch / (mm)	
1 <sup>9, 10</sup>	(25)	6	(150)	1.0 (25)	0.5	0.7	35.8°	1°	0.8	225	26	3.0	2.0	2.3	4.3	3.13	4	0.625
1.5 <sup>9</sup>	(40)				0.5	0.7	29.9°	1°	1.8	225	26	6.0	2.5	2.3	5.0	3.88	4	0.625
2 <sup>9</sup>	(50)				0.5	0.7	25.2°	1°	3.1	225	26	7.0	4.0	2.8	6.0	4.75	4	0.750
2.5 <sup>9</sup>	(65)				0.5	0.7	20.6°	1°	4.9	225	26	7.5	4.5	2.8	7.0	5.50	4	0.750
3	(80)				0.5	0.7	17.4°	1°	7.1	225	26	9.5	5.5	2.8	7.5	6.00	4	0.750
4	(100)				0.5	0.7	13.2°	1°	12.6	225	26	13.0	8.0	2.8	9.0	7.50	8	0.750
5	(125)				0.5	0.7	12.0°	1°	19.6	225	26	14.0	8.5	4.0	10.0	8.50	8	0.875
6	(150)				0.5	0.7	11.1°	1°	28.3	225	26	16.0	9.5	4.0	11.0	9.50	8	0.875
8	(200)	8	(200)	1.5 (38)	0.7	1.0	8.4°	1°	50.3	225	26	20.0	14.5	8.0	13.5	11.75	8	0.875
10	(250)				0.7	1.0	8.1°	1°	78.5	225	26	28.0	17.0	10.0	16.0	14.25	12	1.000
12	(300)				0.7	1.0	7.3°	1°	113.1	225	26	44.0	24.5	10.0	19.0	17.00	12	1.000
14	(350)				0.7	1.0	6.3°	1°	153.9	150	26	50.0	27.0	12.0	21.0	18.75	12	1.125
16	(400)				0.7	1.0	5.9°	1°	201.1	150	26	59.0	33.5	15.0	23.5	21.25	16	1.125
18	(450)				0.7	1.0	5.3°	1°	254.5	150	26	68.0	34.0	16.5	25.0	22.75	16	1.250
20	(500)				0.7	1.0	4.8°	1°	314.2	150	26	79.0	38.0	16.5	27.5	25.00	20	1.250
24	(600)				0.7	1.0	3.9°	1°	452.4	150	26	91.0	48.0	20.0	32.0	29.50	20	1.375
30	(750)	10	(250)	1.7 (44)	0.7	1.0	3.8°	1°	706.9	125	26	129.0	63.0	29.5	38.8	36.00	28	1.375
36	(900)				0.7	1.0	3.1°	1°	1017.9	125	26	160.0	76.0	43.0	46.0	42.75	32	1.625
48	(1200)				0.7	1.0	2.7°	1°	1809.6	100	26	244.0	132.0	44.0	59.5	56.00	44	1.625

- Notes:
- The degree of angular movement is based on the maximum rated extension.
  - Torsional movement is expressed when the expansion joint is a neutral length.
  - To determine "end thrust", multiply thrust factor by operating pressure of system.
  - Pressure rating is based on 170°F operating temperature. At higher temperature the pressure rating is slightly reduced.
  - Weights are approximate.
  - Control unit weight consists of one rod, four washers, three nuts and two control rod plates. Multiply number of control units needed for application (as specified in the Fluid Sealing Association Technical Handbook) to determine correct weights.
  - Dimensions shown are in accordance with 125/150# standards of ANSI B-16.1, B-16.24, B-16.5; AWWA C-207 Table 1 and 2 Class D.
  - 1" I.D. through 12" I.D. have white PTFE liners.
  - 12" I.D. through 48" I.D. have clear FEP liners.
  - Teflon liner extends to bolt holes' center line only.
  - Available in filled arch configuration only.



2431 North Wigwam Dr. (95205)  
P.O. Box 590 • Stockton, CA  
95201-0590 • USA

**PROCO™ Series 251 Products Are Designed To Absorb Different Movements Concurrently.**

Axial Compression

Axial Elongation

Angular Movement  
Bending Of The Centerline

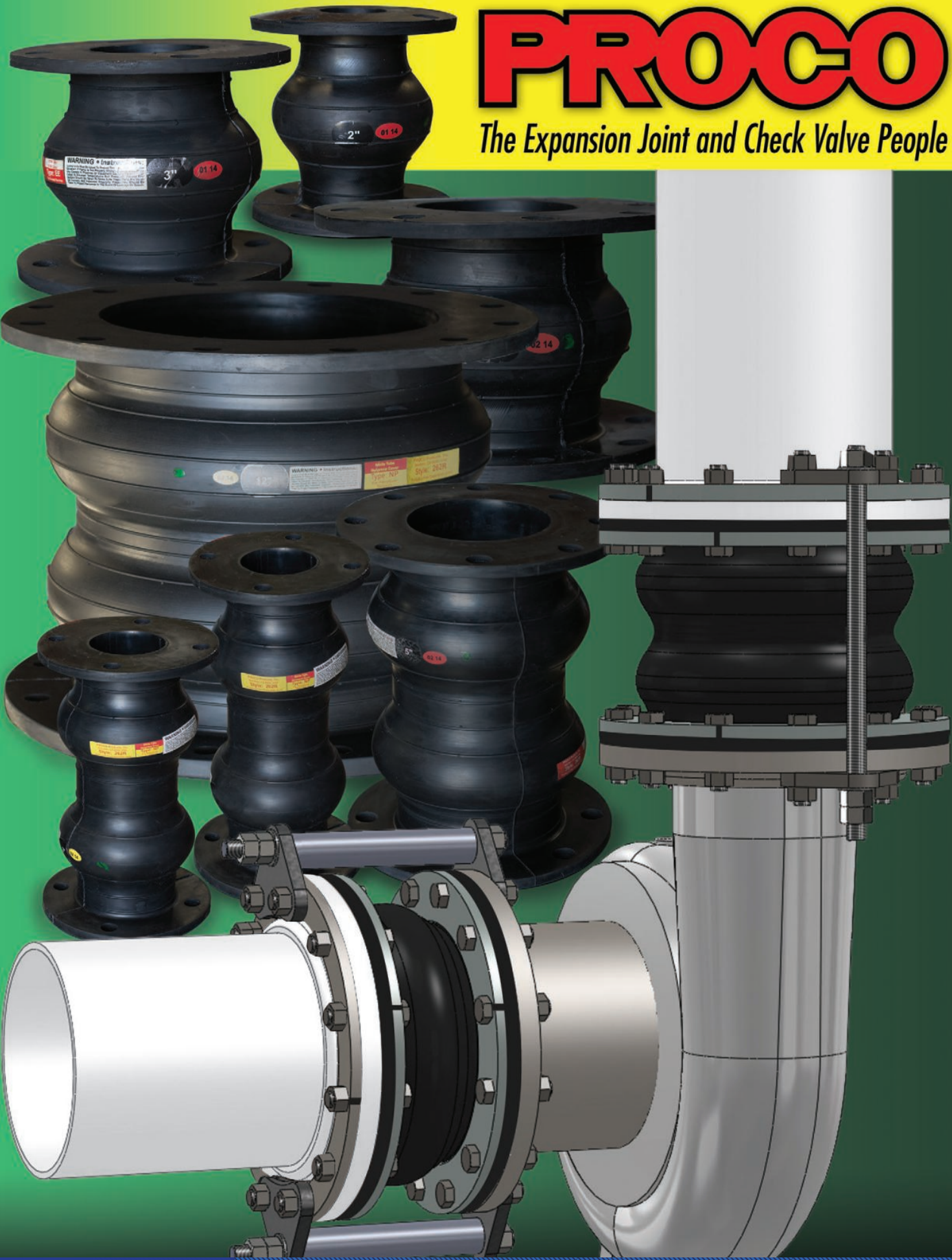
Torsional Movement  
Rotation About The Centerline (Twist)

**DISTRIBUTED BY:**

Warning: Expansion joints may operate in pipelines or equipment carrying fluids and/or gases at elevated temperatures and pressures. Normal precautions should be taken to make sure these parts are installed correctly and inspected regularly. Precautions should be taken to protect personnel in the event of leakage or splash. Note: Piping must be properly aligned and anchored to prevent damage to an expansion joint. Movement must not exceed specified ratings and control units are always recommended to prevent dam-

# PROCO

*The Expansion Joint and Check Valve People*



**WELDED WIDE ARCH EXPANSION JOINT SERIES 260R**

**GOODYEAR**  
RUBBER PRODUCTS, INC.

☎ **727-342-5088**

You can also email us at  
[GRP@goodyearrubberproducts.com](mailto:GRP@goodyearrubberproducts.com)

# Proco Series 260R Molded Wide Arch Expansion Joints

**Proco Series 260R** Molded Wide Arch Expansion Joints are specifically designed for use with Plastic or FRP Piping Systems. An option for the standard spool-type expansion joints, the PROCO Style 261R & Style 262R have lower spring forces to compress, extend or laterally offset. The PROCO Styles 261R & 262R can be used on plastic or FRP pipes, pumps, valves and tanks without fear of the expansion joint being stronger than the pipe, pump, valve or tank flanges. In addition the PROCO Styles 261R & 262R are designed for tough demanding applications, as found in: Chemical & Petrochemical, Pulp Paper, Process Facilities, Industrial Piping Pollution Control Systems. The PROCO Styles 261R & 262R may be used where metallic hoses/expansion joints or old design rubber expansion joints may have been specified previously. Used on plastic tanks, pumps, chillers, cooling towers, compressors, blowers, fans, absorption machines, etc to: (1) Absorb Pipe Movements/Stress, (2) Reduce System Noise, (3) Isolate Mechanical Vibrations, (4) Compensate Alignment/Offset, (5) Eliminate Electrolytic Action and Electrolysis, (6) Protect Against Start-Up/Surge Forces.

## Features and Benefits:

### Low Spring Rates

The Styles 261R & 262R have the lowest spring rates and forces to deflect of any expansion joint made today.

### Absorbs Directional Movement

Thermal movements appear in any rigid pipe system due to temperature changes. The Series 260R wide arch expansion joints allow for axial compression or axial extension, lateral deflection as well as angular and torsional movements. (Note: Rated movements in this publication are based on one plane movements. Multiple movement conditions are based on a multiple movement calculation.)

### Absorbs Vibration, Noise and Shock

The Proco Series 260R rubber expansion joints effectively dampen and insulate downstream piping against the transmission of noise and vibration generated by mechanical equipment. Noise and vibrations caused by equipment can cause stress in pipe, pipe guides, anchors and other equipment downstream. The Series 260R expansion joints will help relieve noise and vibration occurrences in a pipe system. Water hammer and pumping impulses can also cause strain, stress or shock to a piping system. Install the Series 260R to help compensate for these system pressure spikes.

### Compensates for Misalignment

Rubber expansion joints are commonly used by contractors and plant personnel to allow for slight pipe misalignment during installation of new piping and or replacement applications. Installation tolerance should be kept to 1/8" per Fluid Sealing Association guidelines ([www.fluidsealing.com](http://www.fluidsealing.com)).

### Self-Cleaning Wide Arch

The arches of the Series 260R are wide enough to allow the normal flow of the media to keep the arch clean of solids.

### Flange Materials/Drilling

All PROCO Style 261R & 262R Molded Wide Arch Expansion Joints are drilled in accordance with ANSI 125/150# Standards. They should be installed against a flat face flange with the use of unique retaining rings specifically designed for the 260R series. Rings are fabricated from plate steel; zinc plated to prevent corrosion. Retaining rings are also available in 304 or 316 Stainless Steel upon request. Gaskets are not required with PROCO Styles 261R or Style 262R.

### Less Weight

The steel flanges of a spherical design (240/242) are heavy, especially for plastic or fiberglass piping applications. The Style 261R & Style 262R Expansion Joints, including retaining rings, are considerably lighter than the spherical designs.

### Large Inventory

Proco Products, Inc. maintains one of the largest inventories of rubber expansion joints in the world. Please contact us for price and availability.

**Table 1: Available Styles • Materials**

For Specific Elastomer Recommendations, See: <b>PROCO "Chemical To Elastomer Guide"</b>							
261-R <sup>1</sup>	262-R <sup>1</sup>	PROCO Material Code	Cover <sup>2</sup> Elastomer	Tube Elastomer	Maximum Operating Temp. °F (°C)	Banding Label Color	F.S.A. Material Class
X	X	/BB	Chlorobutyl	Chlorobutyl	250° (121°)	Black	STD. III
S	S	/EE	EPDM	EPDM	250° (121°)	Red	STD. III
S	S	/NH	Neoprene	CSM	212° (100°)	Green	STD. II
X	X	/NN	Neoprene	Neoprene	225° (107°)	Blue	STD. II
S	S	/NP	Neoprene	Nitrile	225° (107°)	Yellow	STD. II

**261R Single Molded Wide Arch**

**262R Double Molded Wide Arch**



**Protecting Piping and Equipment Systems from Stress/Motion**

# Style 261R Single Molded Wide Arch Performance Data

**Table 2: Sizes • Movements • Spring Rates • Pressures • Weights**

Expansion Joint Size Nom. I.D. x Inch / (mm)	Neutral Length Inch / (mm)	261R Movement Capability: From Neutral Position <sup>1</sup>					Spring Rates			Operating Conditions <sup>2</sup>		Weights in lbs <sup>3</sup> (KGS)			
		Axial Compression Inch / (mm)	Axial Extension Inch / (mm)	Lateral Deflection Inch / (mm)	Angular Deflection <sup>4</sup> (Degrees)	Torsional Rotation <sup>5</sup> (Degrees)	Thrust Factor <sup>6</sup> In2 / (cm2)	Force Pounds for 1" Axial Compression lb/in / (N/mm)	Force Pounds for 1" Axial Extension lb/in / (N/mm)	Force Pounds for 1" Lateral Deflection lb/in / (N/mm)	Positive PSIG / (Bar)	Vacuum Inches of Hg/ (mm of Hg)	Expansion Joint	Retaining Ring Set	Control Unit Assembly <sup>7</sup>
<b>1.5</b> (40)	6 (150)	1.5 (38)	0.625 (16)	0.750 (19)	28	5	11.04 (71)	126 (22)	182 (32)	149 (26)	225 (15.5)	24 (610)	1.3 (0.59)	2.5 (1.1)	2.3 (1.0)
<b>2</b> (50)			0.625 (16)	0.750 (19)	25	5	14.18 (92)	132 (23)	158 (28)	130 (23)	225 (15.5)	24 (610)	1.7 (0.77)	4.0 (1.8)	2.8 (1.3)
<b>2.5</b> (65)			0.625 (16)	0.750 (19)	20	5	17.71 (114)	128 (22)	141 (25)	111 (19)	225 (15.5)	24 (610)	2.1 (0.95)	4.5 (2.0)	2.8 (1.3)
<b>3</b> (80)			0.625 (16)	0.750 (19)	18	5	21.64 (140)	139 (24)	208 (36)	133 (23)	225 (15.5)	24 (610)	2.4 (1.0)	5.5 (2.5)	2.8 (1.3)
<b>4</b> (100)			0.625 (16)	0.750 (19)	14	4	30.66 (198)	110 (19)	180 (32)	105 (18)	225 (15.5)	24 (610)	3.2 (1.4)	6.0 (2.7)	2.8 (1.3)
<b>5</b> (125)			0.625 (16)	0.750 (19)	13	4	41.26 (266)	143 (25)	190 (33)	136 (24)	225 (15.5)	24 (610)	3.6 (1.6)	8.5 (3.9)	4.0 (1.8)
<b>6</b> (150)			0.625 (16)	0.750 (19)	12	4	53.43 (345)	136 (24)	166 (29)	147 (26)	225 (15.5)	24 (610)	4.9 (2.2)	9.5 (4.3)	4.0 (1.8)
<b>8</b> (200)			0.625 (16)	0.750 (19)	12	4	82.47 (532)	226 (40)	230 (40)	210 (37)	210 (14.8)	24 (610)	7.7 (3.5)	14.5 (6.6)	8.0 (3.6)
<b>10</b> (250)	8 (200)	2.25 (57)	0.750 (19)	1.0 (25)	12	4	135.13 (872)	248 (43)	381 (67)	281 (49)	210 (14.8)	24 (610)	13.9 (6.3)	17.0 (7.7)	10.0 (4.5)
<b>12</b> (300)			0.750 (19)	1.0 (25)	11	4	179.46 (1158)	378 (66)	493 (86)	409 (72)	210 (14.8)	24 (610)	19.5 (8.8)	24.5 (11.0)	10.0 (4.5)
<b>14</b> (350)			0.750 (19)	1.0 (25)	11	3	230.08 (1484)	423 (74)	592 (104)	497 (87)	150 (10.3)	24 (610)	22.7 (10.3)	27.0 (12.3)	12.0 (5.4)
<b>16</b> (400)			0.750 (19)	1.0 (25)	10	3	286.98 (1852)	432 (74)	606 (106)	509 (89)	150 (10.3)	24 (610)	26.8 (12.2)	33.5 (15.3)	15.0 (6.8)
<b>18</b> (450)			0.750 (19)	1.0 (25)	8	3	350.15 (2259)	543 (95)	761 (133)	690 (121)	150 (10.3)	24 (610)	29.5 (13.4)	34.0 (15.5)	16.0 (7.2)
<b>20</b> (500)			0.750 (19)	1.0 (25)	8	3	419.61 (2707)	628 (110)	829 (145)	776 (136)	150 (10.3)	24 (610)	31.8 (17.3)	38.0 (17.3)	16.0 (7.2)

**NOTES:**

1. Concurrent Movements - Concurrent movements are developed when two or more movements in a pipe system occur at the same time.

If multiple movements exceed single arch design there may be a need for additional arches.

To perform calculation for concurrent movement when a pipe system design has more than one movement, please use the following formula:

$$\frac{\text{Actual Axial Compression} + \text{Actual Axial Extension} + \text{Actual Lateral (X)} + \text{Actual Lateral (Y)}}{\text{Rated Axial Compression} + \text{Rated Axial Extension} + \text{Rated Lateral (X)} + \text{Rated Lateral (Y)}} = / < 1$$

Calculation must be equal to or less than 1 for expansion joint to operate within concurrent movement capability.

2. Pressure rating is based on 194°F operating temperature. At higher temperature the pressure rating is slightly reduced.

Vacuum rating is expressed when expansion joint is at neutral length.

3. Weights are approximate.

4. The degree of angular movement is based on the maximum rated extension.

5. Torsional movement is expressed when the expansion joint is at neutral length.

6. To determine "end thrust," multiply thrust factor by operating pressure of system.

7. Limit rod control unit weight consists of one rod with washers, nuts and two limit rod plates. Multiply number of limit rods needed for the application (as specified in the Fluid Sealing Association's Technical Handbook, 7.3 Edition or table 5 in this manual) to determine correct weights.

**"Effective Area"**

Thrust Factor=

$$T = \frac{\pi}{4} (D)^2 (P)$$

T= Thrust  
P= PSI (Design, Test or Surge)  
D= Arch I.D.

# Style 262R Double Molded Wide Arch Performance Data

**Table 3: Sizes • Movements • Spring Rates • Pressures • Weights**

Expansion Joint Size Nom. I.D. x Inch / (mm)	Neutral Length Inch / (mm)	262R Movement Capability: From Neutral Position <sup>1</sup>						Spring Rates			Operating Conditions <sup>2</sup>		Weights in lbs <sup>3</sup> (KGS)		
		Axial Compression Inch / (mm)	Axial Extension Inch / (mm)	Lateral Deflection Inch / (mm)	Angular Deflection <sup>4</sup> (Degrees)	Torsional Rotation <sup>5</sup> (Degrees)	Thrust Factor <sup>6</sup> In <sup>2</sup> / (cm <sup>2</sup> )	Force Pounds for 1" Axial Compression lb/in / (N/mm)	Force Pounds for 1" Axial Extension lb/in / (N/mm)	Force Pounds for 1" Lateral Deflection lb/in / (N/mm)	Positive PSIG / (Bar)	Vacuum Inches of Hg (mm of Hg)	Expansion Joint	Retaining Ring Set	Control Unit Assembly <sup>7</sup>
<b>2</b> (50)	12 (300)	2.5 (64)	1.25 (32)	1.625 (41)	40	5	14.18 (92)	99 (17.25)	118.5 (21)	97.5 (17.25)	150 (10.3)	24 (610)	4.0 (1.8)	4.0 (1.8)	3.4 (1.5)
<b>2.5</b> (65)					40	5	17.71 (114)	96 (16.5)	105.75 (18.75)	83.25 (14.25)	150 (10.3)	24 (610)	5.0 (2.27)	4.5 (2.0)	3.4 (1.5)
<b>3</b> (80)					36	5	21.64 (140)	104 (18)	156 (27)	99.75 (17.25)	150 (10.3)	24 (610)	5.0 (2.27)	5.5 (2.5)	3.4 (1.5)
<b>4</b> (100)					30	4	30.66 (198)	82 (14.25)	135 (24)	78.75 (13.5)	150 (10.3)	24 (610)	6.0 (2.72)	6.0 (2.7)	3.4 (1.5)
<b>5</b> (125)					30	4	41.26 (266)	107 (18.75)	142.5 (24.75)	102 (18)	150 (10.3)	24 (610)	9.0 (4.08)	8.5 (3.9)	4.8 (2.2)
<b>6</b> (150)					30	4	53.43 (345)	102 (18)	124.5 (21.75)	110.25 (19.5)	150 (10.3)	24 (610)	11 (4.99)	9.5 (4.3)	4.8 (2.2)
<b>8</b> (200)					30	4	82.47 (532)	169 (30)	172.5 (30)	157.5 (27.75)	150 (10.3)	24 (610)	13 (5.90)	14.5 (6.6)	9.6 (4.4)
<b>10</b> (250)	14 (350)	3.25 (83)	1.375 (35)	1.25 (32)	20	4	135.13 (872)	186 (32.25)	285.75 (50.25)	210.75 (36.75)	150 (10.3)	24 (610)	22 (9.98)	17.0 (7.7)	12.0 (5.4)
<b>12</b> (300)		4 (102)	1.625 (41)	1.25 (32)	16	4	179.46 (1158)	283 (49.5)	369.75 (64.5)	306.75 (54)	150 (10.3)	24 (610)	31 (14.06)	24.5 (11.0)	12.0 (5.4)

**NOTES:**

1. Concurrent Movements - Concurrent movements are developed when two or more movements in a pipe system occur at the same time. If multiple movements exceed single arch design there may be a need for additional arches. To perform calculation for concurrent movement when a pipe system design has more than one movement, please use the following formula:

$$\frac{\text{Actual Axial Compression} + \text{Actual Axial Extension} + \text{Actual Lateral (X)} + \text{Actual Lateral (Y)}}{\text{Rated Axial Compression} + \text{Rated Axial Extension} + \text{Rated Lateral (X)} + \text{Rated Lateral (Y)}} = / < 1$$

Calculation must be equal to or less than 1 for expansion joint to operate within concurrent movement capability.

2. Pressure rating is based on 194°F operating temperature. At higher temperature the pressure rating is slightly reduced. Vacuum rating is expressed when expansion joint is at neutral length.

3. Weights are approximate.

4. The degree of angular movement is based on the maximum rated extension.

5. Torsional movement is expressed when the expansion joint is at neutral length.

6. To determine "end thrust," multiply thrust factor by operating pressure of system.

7. Limit rod unit weight consists of one rod with washers, nuts and two limit rod plates. Multiply number of limit rods needed for the application (as specified in the Fluid Sealing Association's Technical Handbook, Seventh Edition or table 5 in this manual) to determine correct weights.

8. Limit/Control rods are recommended on all 262R expansion joints.

9. When limit/Control Units are required, use additional set of retaining rings on back side of mating flange when connecting to PVC, CPVC or FRP to improve stiffness. See back cover for details.

**"Effective Area"**

Thrust Factor=

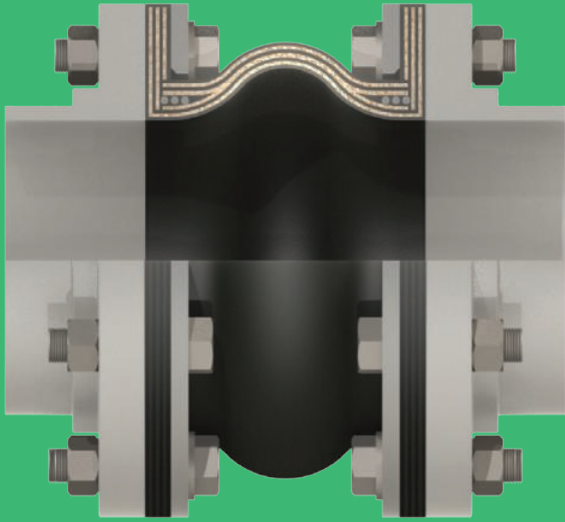
$$T = \frac{\pi}{4} (D)^2 (P)$$

T= Thrust  
P= PSI (Design, Test or Surge)  
D= Arch I.D.

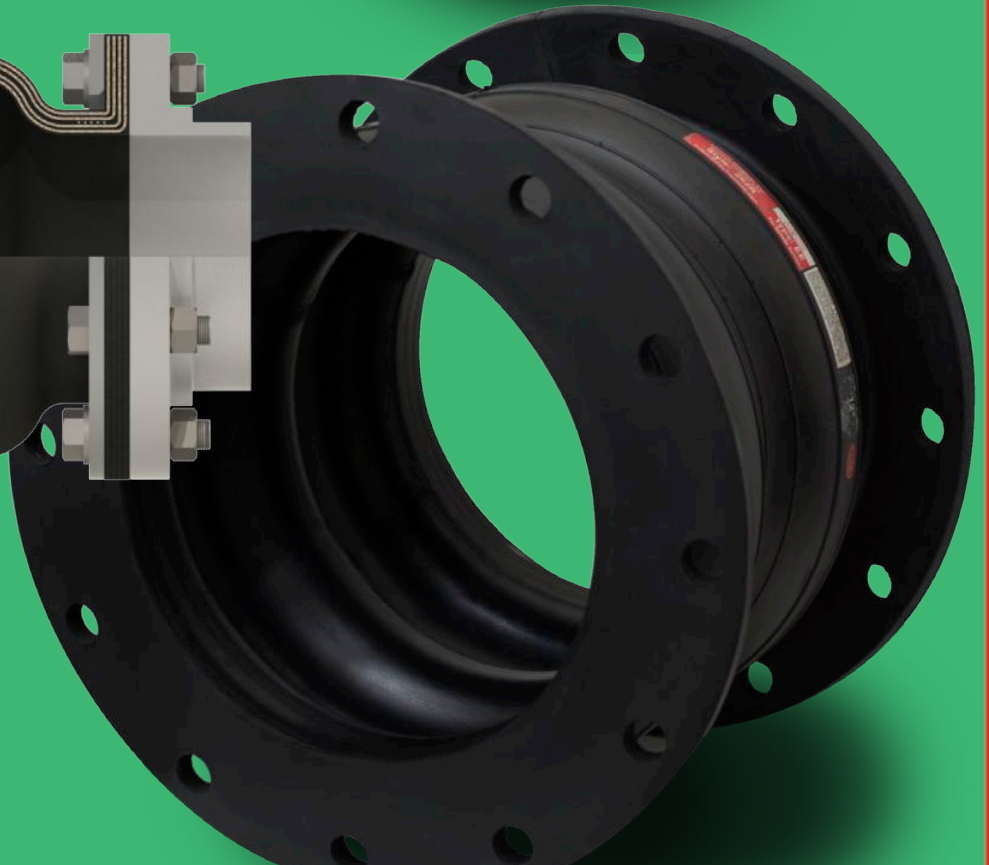
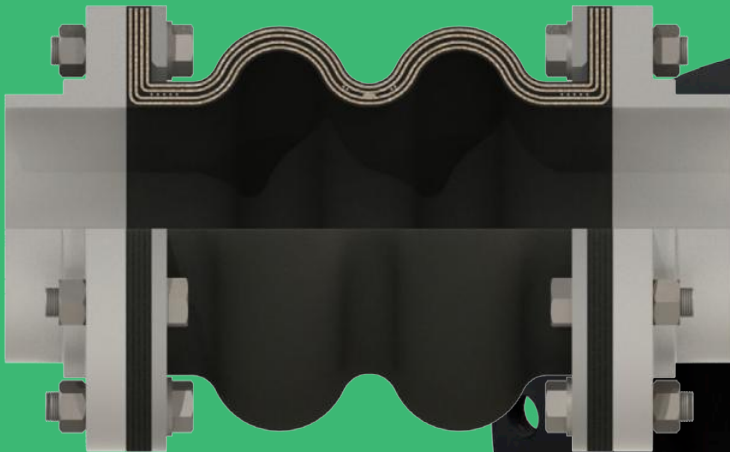


# Series 260R

Style 261R



Style 262R



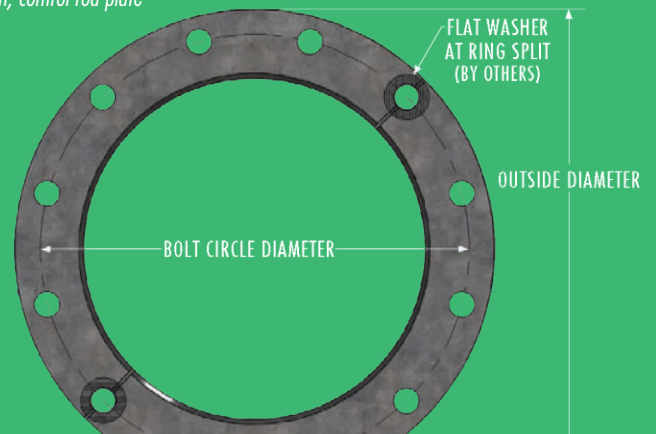
# Series 260 Drilling Chart

Table 4		Standard Drilling for PROCO Rubber Expansion Joints						Thickness of Materials for PROCO Rubber Expansion Joints						Control Unit Plate Detail					
Nominal Pipe Size Expansion Joint I.D. Inch / (mm)		Flange Dimensions <sup>2</sup>						Material Thickness <sup>1</sup> for Bolt Length Requirements						Control Unit Plate Detail					
		Flange O.D. Inch / (mm)		Bolt Circle Inch / (mm)		Number Of Holes	Size Of Holes Inch / (mm)		Retaining Rings Thickness Inch / (mm)		Rubber Flange Thickness Inch / (mm)		Adjacent <sup>3</sup> Mating Flange Thickness					Max. Control <sup>4</sup> Rod Plate Thickness Inch / (mm)	
<b>1.5</b>	(40)	5.00	(127.00)	3.88	(98.55)		4	0.625	(15.9)	0.375	(9.53)	0.375		(9.53)	TO SPECIFY MATING FLANGE THICKNESS	0.375	(9.53)	9.125	(231.8)
<b>2</b>	(50)	6.00	(152.40)	4.75	(120.65)	4	0.750	(19.05)	0.375	(9.53)	0.375	(9.53)	0.375	(9.53)		10.125	(257.2)	0.625	(15.9)
<b>2.5</b>	(65)	7.00	(177.80)	5.50	(139.70)	4	0.750	(19.05)	0.375	(9.53)	0.375	(9.53)	0.375	(9.53)		11.125	(282.6)	0.625	(15.9)
<b>3</b>	(80)	7.50	(190.50)	6.00	(152.40)	4	0.750	(19.05)	0.375	(9.53)	0.375	(9.53)	0.375	(9.53)		11.625	(295.3)	0.625	(15.9)
<b>4</b>	(100)	9.00	(228.60)	7.50	(190.50)	8	0.750	(19.05)	0.375	(9.53)	0.375	(9.53)	0.375	(9.53)		13.125	(333.4)	0.625	(15.9)
<b>5</b>	(125)	10.00	(254.00)	8.50	(215.90)	8	0.875	(22.23)	0.375	(9.53)	0.375	(9.53)	0.500	(12.70)		14.125	(358.8)	0.625	(15.9)
<b>6</b>	(150)	11.00	(279.40)	9.50	(241.30)	8	0.875	(22.23)	0.375	(9.53)	0.375	(9.53)	0.500	(12.70)		15.125	(384.2)	0.625	(15.9)
<b>8</b>	(200)	13.50	(342.90)	11.75	(298.45)	8	0.875	(22.23)	0.375	(9.53)	0.390	(10)	0.750	(19.05)		19.125	(485.8)	1.000	(25.4)
<b>10</b>	(250)	16.00	(406.40)	14.25	(361.95)	12	1.000	(25.40)	0.375	(9.53)	0.625	(15.88)	0.750	(19.05)		21.625	(549.3)	1.000	(25.4)
<b>12</b>	(300)	19.00	(482.60)	17.00	(431.80)	12	1.000	(25.40)	0.375	(9.53)	0.625	(15.88)	0.750	(19.05)		24.625	(625.5)	1.000	(25.4)
<b>14</b>	(350)	21.00	(533.40)	18.75	(476.25)	12	1.125	(28.58)	0.375	(9.53)	0.625	(15.88)	0.750	(19.05)		26.625	(676.3)	1.000	(25.4)
<b>16</b>	(400)	23.50	(596.90)	21.25	(539.75)	16	1.125	(28.58)	0.375	(9.53)	0.625	(15.88)	0.750	(19.05)		30.125	(765.2)	1.250	(31.8)
<b>18</b>	(450)	25.00	(635.00)	22.75	(577.85)	16	1.250	(31.75)	0.375	(9.53)	0.625	(15.88)	0.750	(19.05)		31.625	(803.3)	1.250	(31.8)
<b>20</b>	(500)	27.50	(698.50)	25.00	(635.00)	20	1.250	(31.75)	0.375	(9.53)	0.625	(15.88)	0.750	(19.05)		34.125	(866.8)	1.250	(31.8)

Metric Conversion Formula: Nominal I.D.: in. x 25 = mm; Dimensions/Thickness': in. x 25.4 = mm.

**Notes:**

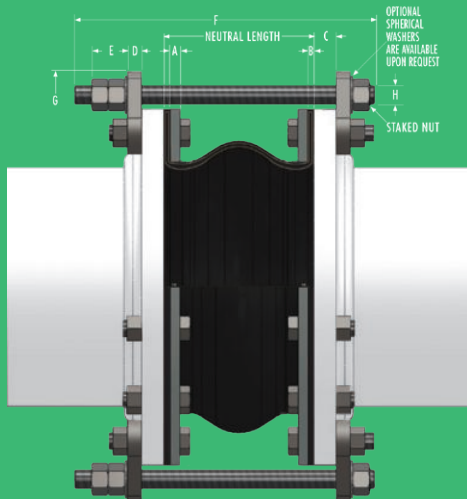
- Limit/Control Rod length is determined by neutral length of rubber expansion joint, rated extension, control rod plate thickness, mating flange thickness and number of nuts. Consult PROCO for rod lengths.
- Flange Dimensions shown are in accordance with ANSI B16.1 and ANSI B16.5 Class 125/150, AWWA C-207-07, Tbl 2 and 3 - Class D, Table 4 - Class E. Hole size shown is 1/8" larger than AWWA Standard.
- Adjacent mating flange thickness is required to determine overall rod length and compression sleeve length (if required).
- Plate thickness is based on a maximum width PROCO would use to design a Limit/Control Rod plate.
- Flat Washers required at ring splits and are by others.
- Control rod plate O.D. installed dimension is based on a maximum O.D. Proco would supply.
- Control rod diameter is based on a maximum diameter Proco would use to design a control rod.



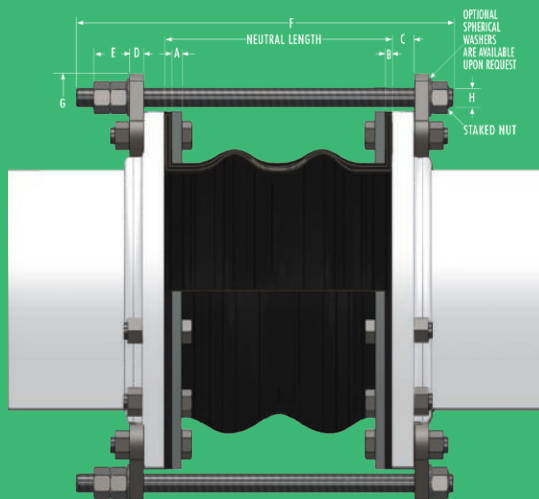
- A** - Retaining Ring Thickness.
- B** - Rubber Flange Thickness.
- C** - Adjacent Mating Flange Thickness (By Others).
- D** - Control Unit Plate Thickness.

- E** - Double Nut Thickness is determined by Control Rod Diameter.
- F** - Control Rod Bolt Length is determined by A through E + OAL <sup>1</sup>.
- G** - Control Rod Control Rod Plate O.D.
- H** - Maximum Rod Diameter

### Limit Rods

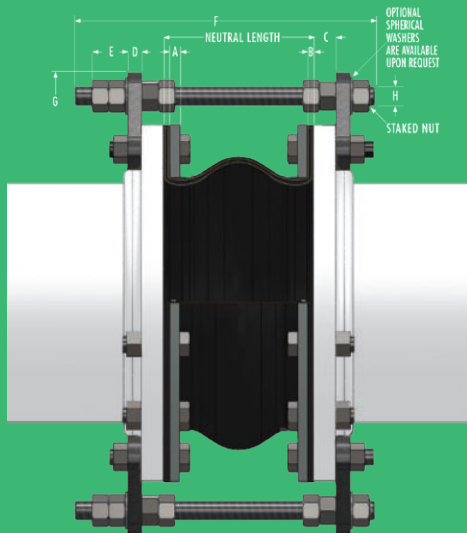


**Figure 1**  
Style 261R

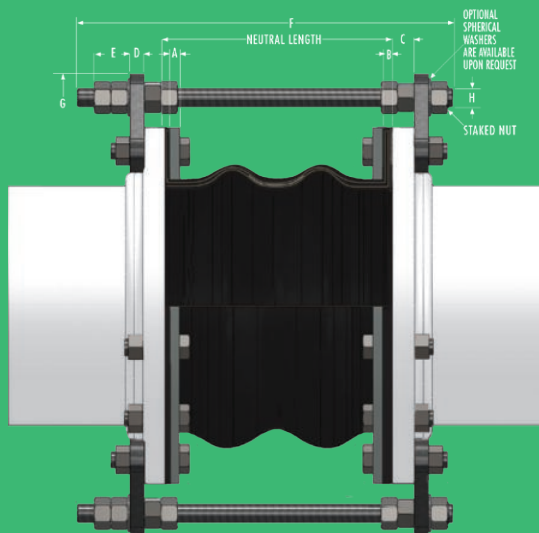


**Figure 1**  
Style 262R

### Control Rod Internal Nuts

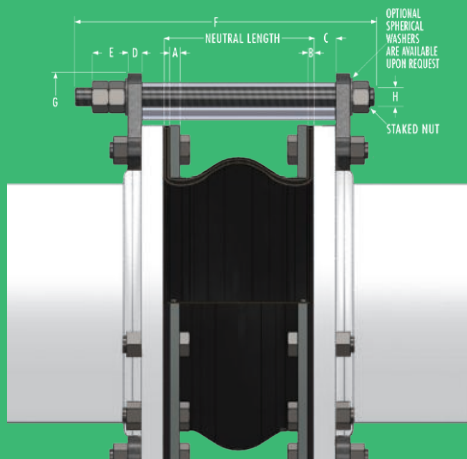


**Figure 2**  
Style 261R

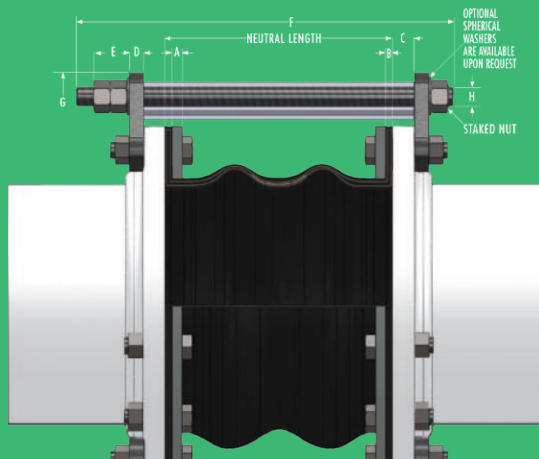


**Figure 2**  
Style 262R

### Control Rod Compression Sleeves



**Figure 3**  
Style 261R



**Figure 3**  
Style 262R

# Limit Rods, Control Rods & Compression Sleeves

## Use of Control Units with Rubber Expansion Joints

### Definition

A control unit assembly is a system of two or more control rod units (limit rods, tie rods or compression sleeves) placed across an expansion joint from flange to flange to minimize possible damage caused by excessive motion of a pipeline. The control unit assemblies can be set at the maximum allowable expansion and/or contraction of the rubber expansion joint. When used in this manner, control units are an additional safety factor and can minimize possible damage to adjacent equipment.

Rubber expansion joints should be installed between two fixed anchor points in a piping system. The pipe system must be rigidly anchored on both sides of the expansion joint to control expansion or contraction of the line. Piping anchors must be capable of withstanding the line thrusts generated by internal pressure or wide temperature fluctuations.

When proper anchoring cannot be provided, **CONTROL UNITS ARE REQUIRED**. For un-anchored piping systems nuts shall be tightened snug against rod plate to prevent over extension due to pressure thrust created by expansion joint. Refer to "Thrust Factor in Tables 2 & 3, note 6 in this manual.

Listed below are three (3) control unit configurations supplied by PROCO and are commonly used with rubber expansion joints in piping systems.

### Figure 1

Known as a **LIMIT ROD**, this control unit configuration will allow an expansion joint to extend to a predetermined extension setting. Nuts shall be field set to no more than the maximum allowable extension movement of a rubber expansion joint (unless used in an un-anchored system). Refer to Tables 2 & 3 in this manual for allowable movement capabilities. Spherical washers can also be furnished (upon request) to combat any "nut to plate" binding during offset. **Consult the systems engineer for proper nut settings prior to system operation.**

### Figure 2

Known as a **LIMIT/CONTROL ROD**, this control unit configuration is used to allow specified pipe expansion (expansion joint axial compression) and pipe contraction (expansion joint axial extension) movements. Nuts shall be field set to no more than the maximum allowable extension (unless used in an un-anchored pipe system) or compression of a rubber expansion joint. Refer to Tables 2 & 3 in this manual for allowable movement capabilities. Internal and external nuts can also be field set to allow for no movement in the horizontal plane. This setting will allow the rubber to move laterally while keeping expansion joint thrust forces low on adjacent equipment. Spherical washers can also be furnished (upon request) to combat any potential "nut to plate" binding during offset. **Limit/Control rods with internal nuts must be specified at the time of inquiry. Consult the systems engineer for proper nut settings prior to system operation.**

### Figure 3

Known as a **COMPRESSION SLEEVE**, this configuration is used to allow for specified pipe expansion (expansion joint axial compression) and pipe contraction (expansion joint extension) movements. Nuts shall be field set to no more than the maximum allowable extension (unless used in an un-anchored pipe system) of a rubber expansion joint. Refer to Tables 2 & 3 in this manual for allowable movement capabilities. PROCO will manufacture each compression sleeve to allow for no axial movement unless otherwise specified by the purchaser. Compression sleeves shall be field trimmed to meet required allowable axial movement as set forth by system requirements. Spherical washers can also be furnished (upon request) to combat any potential "nut to plate" binding during offset. **Consult the systems engineer for proper sleeve lengths prior to system operation.**

### Important Control Unit Considerations

The number of rods, control rod diameters and control rod plate thicknesses are important considerations when specifying control units for an application. As a minimum, specifying engineers or purchasers shall follow the guidelines as set forth in Appendix C of the Fluid Sealing Association's Technical Handbook, 7.3 Edition. PROCO engineers its control unit assemblies to system requirements. Our designs incorporate an allowable stress of 65% of material yield for each rod and plate (rod and plate material to be specified by purchaser). Therefore, it is important to provide pressure and temperature ratings to PROCO when requesting control units for rubber

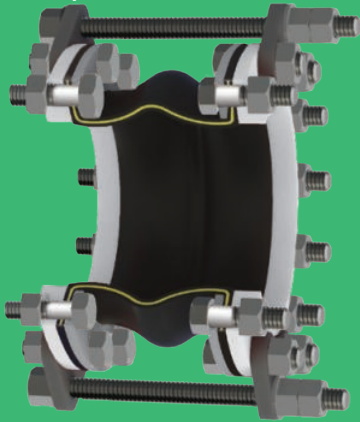
### Installation Instructions for Control Rods

1. Assemble expansion joint between pipe flanges in its manufactured neutral length. Install the retaining rings furnished with the expansion joint.
2. Assemble control rod plates behind pipe flanges as shown. Flange bolts or all thread studs through the control rod plate must be longer to accommodate the plate thickness. Control rod plates should be equally spaced around the flange. Depending upon the size and pressure rating of the system, 2, 3, 4, or more control/limit rods may be required. Refer to Table 5 in this manual or to the Fluid Sealing Association's Technical Handbook, 7.3 Edition, page 23 for control rod pressure ratings ([www.fluidsealing.com](http://www.fluidsealing.com)).
3. Insert control/limit rods through top plate holes. Steel flat washers are to be positioned at outer plate surface.
4. If a single nut per unit is furnished, position this nut so that there is a gap between the nut and the steel flat washer. This gap is equal to the joints maximum extension (commencing with the nominal face-to-face length). To lock this nut in position, either "stake" the thread in two places or tack weld the nut to the rod. If two nuts are supplied, the nuts will create a "jamming" effect to prevent loosening. (Nuts should be snug against flat washer and control rod plate when piping system is un-anchored.)  
*Note: Consult the manufacturer if there are any questions as to the rated compression and elongation. These two dimensions are critical in setting the nuts and sizing the compression pipe sleeve (if supplied).*
5. If there is a requirement for compression pipe sleeves, ordinary pipe may be used, sized in length to allow the joint to be compressed to its normal limit.
6. If there is a requirement for optional spherical washers, these

**Limit Rods** . . . . .

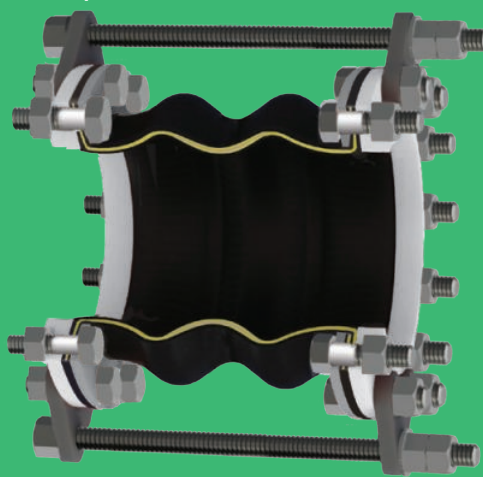
**Figure 1**

Style 261R



**Figure 1**

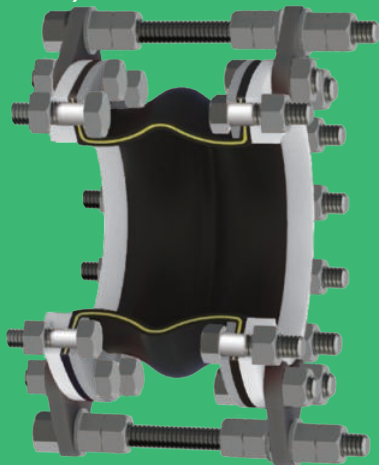
Style 262R



**Control Rod Internal Nuts** . . . . .

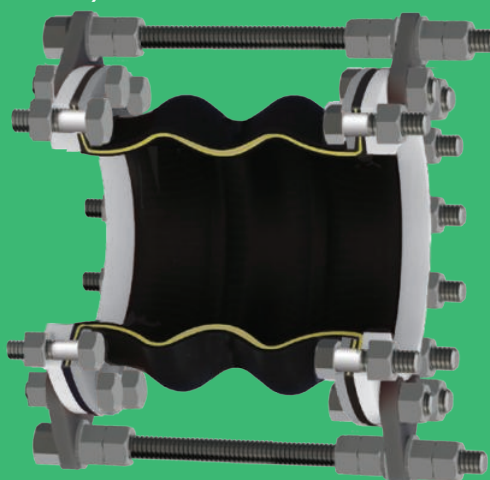
**Figure 2**

Style 261R



**Figure 2**

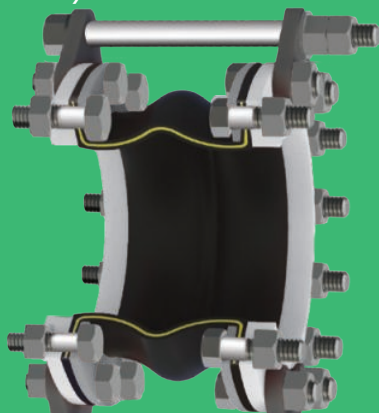
Style 262R



**Control Rod Compression Sleeves** . . . . .

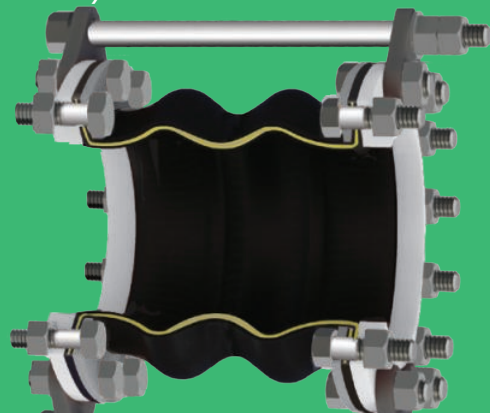
**Figure 3**

Style 261R



**Figure 3**

Style 262R



<b>Table 5</b>		<b>Maximum Surge or Test Pressure of the Systems</b>			
<b>Nominal Pipe Size Expansion Joint I.D.</b>	<b>Inch / (mm)</b>	<b>Number of Control Rods Recommended</b>			
		<b>2</b>	<b>4</b>	<b>6</b>	<b>8</b>
<b>2</b>	(50)	661	•	•	•
<b>2.5</b>	(65)	529	•	•	•
<b>3</b>	(75)	441	•	•	•
<b>4</b>	(100)	311	622	•	•
<b>5</b>	(125)	235	470	•	•
<b>6</b>	(150)	186	371	•	•
<b>8</b>	(200)	163	326	•	•
<b>10</b>	(250)	163	325	488	•
<b>12</b>	(300)	160	320	481	•
<b>14</b>	(350)	112	223	335	•
<b>16</b>	(400)	113	227	340	453
<b>18</b>	(450)	94	187	281	375
<b>20</b>	(500)	79	158	236	315

*Note:*  
Pressures listed above do not relate to the actual design pressure of the expansion joint products, but are the maximum surge or pressure for a specific control rod nominal pipe size.

# Installation Instructions for Non-Metallic Expansion Joints

## 1. Service Conditions:

Make sure the expansion joint rating for temperature, pressure, vacuum and movements match the system requirements. Contact the manufacturer for advice if the system requirements exceed those of the expansion joint selected. Check to make sure the elastomer selected is chemically compatible with the process fluid or gas.

## 2. Alignment:

Expansion joints are normally not designed to make up for piping misalignment errors. Piping should be lined up within 1/8". Misalignment reduces the rated movements of the expansion joint and can induce severe stress and reduce service life. Pipe guides should be installed to keep the pipe aligned and to prevent undue displacement.

## 3. Anchoring:

Solid anchoring is required wherever the pipeline changes direction and expansion joints should be located as close as possible to anchor points. If piping is not adequately anchored, control rods should be used. If anchors are not used, pressure thrust may cause excessive movement damaging the expansion joint.

## 4. Pipe Support:

Piping must be supported by hangers or anchors so expansion joints do not carry any pipe weight.

## 5. Mating Flanges:

Install the expansion joint against the mating pipe flanges and install bolts so that the bolt head and washer are against the retaining rings. If washers are not used, flange leakage can result — particularly at the split in the retaining rings. Flange-to-flange dimension of the expansion joint must match the breach opening. Make sure the mating flanges are clean and are flat faced type or no more than 1/16" raised face type. **(Never install expansion joints that utilize split retaining rings next to wafer type check or butterfly valves. Serious damage can result to a rubber joint of this type unless installed against full face flanges).**

## 6. Bolting Torque:

Table 6 shows the recommended torque ranges for non-metallic expansion joints with full-faced rubber flanges: Torque specifications are approximate. Tighten bolts in stages using cross-bolt tightening pattern. If the joint has integral fabric and rubber flanges, the bolts should be tight enough to make the rubber flange OD bulge between the retaining rings and the mating flange. After installation, the system should be pressurized and examined to confirm a proper seal. Torque bolts sufficiently to assure leak free operation at hydrostatic test pressure. **Note: Torque values are approximate due to mating flange surfaces, installation offsets, operating pressures and environmental conditions.**

Table 6	Approximate
Size	Torque Values
1 1/2" THRU 2 1/2"	30 - 50 ft/lbs
3" THRU 5"	50 - 70 ft/lbs
6" THRU 10"	70 - 110 ft/lbs
12" THRU 14"	100 - 140 ft/lbs
16" THRU 20"	120 - 160 ft/lbs

## 7. Storage:

Ideal storage is in a warehouse with a relatively dry, cool location. Store flanges face down on a pallet or wooden platform. Do not store other heavy items on top of expansion joints. Ten year shelf life can be expected with ideal conditions. If storage must be outdoors, place on wooden platform and joints should not be in contact with the ground. Cover with a tarpaulin.

## 8. Large Joint Handling:

Do not lift with ropes or bars through the bolt holes. If lifting through the bore, use padding or a saddle to distribute the weight. Make sure cables or forklift tines do not contact the rubber. Do not let expansion joints sit vertically on the edges of the flanges for any period of time.

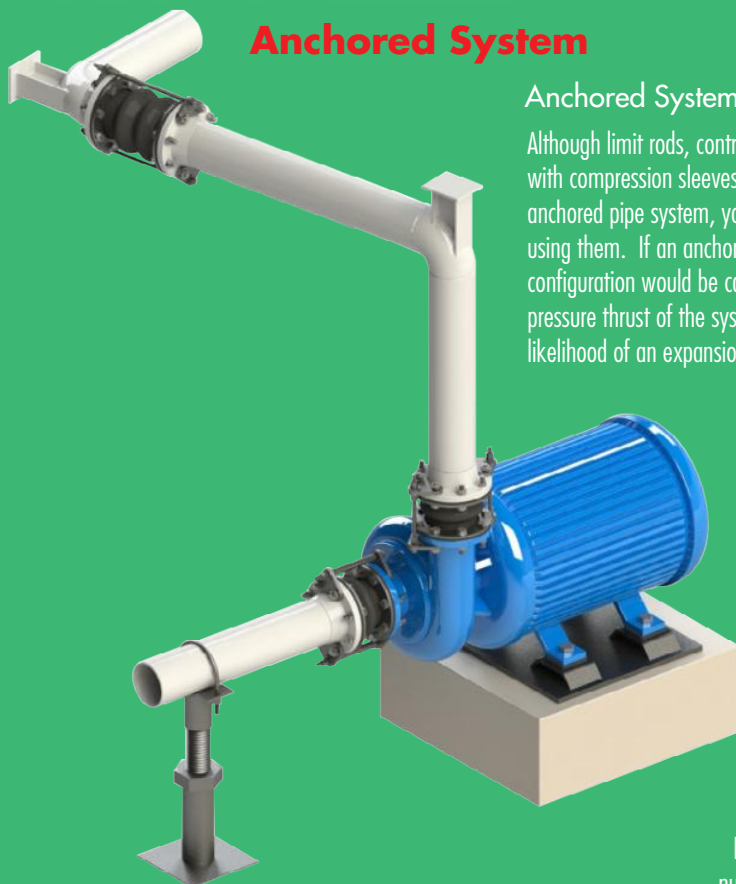
## 9. Additional Tips:

- Do not insulate over a non-metallic expansion joint; however, if insulation is required, it should be made removable to permit easy access to the flanges. This facilitates periodic inspection of the tightness of the joint bolting.
- It is acceptable (but not necessary) to lubricate the expansion joint flanges with a thin film of graphite dispersed in glycerin or water to ease disassembly at a later time.
- Do not weld in the near vicinity of a non-metallic joint.
- If expansion joints are to be installed underground, or will be submerged in water, contact manufacturer for specific recommendations.
- If the expansion joint will be installed outdoors, make sure the cover material will withstand ozone, sunlight, etc.
- Check the tightness of lead-free flanges two or three weeks after installation and retighten if necessary.

*Warning: Expansion joints may operate in pipelines or equipment carrying fluids and/or gasses at elevated temperature and pressures and may transport hazardous materials. Precautions should be taken to protect personnel in the event of leakage or splash. Rubber joints should not be installed in areas where inspection is*

# Piping System Layout Examples

## Anchored System



### Anchored System Note:

Although limit rods, control rods or limit rods with compression sleeves are not required in an anchored pipe system, you may want to consider using them. If an anchor were to fail, any rod configuration would be capable of handling the pressure thrust of the system and lessen the likelihood of an expansion joint failure.

## Un-Anchored System

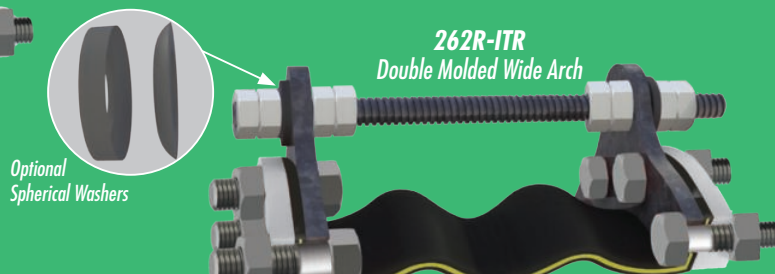
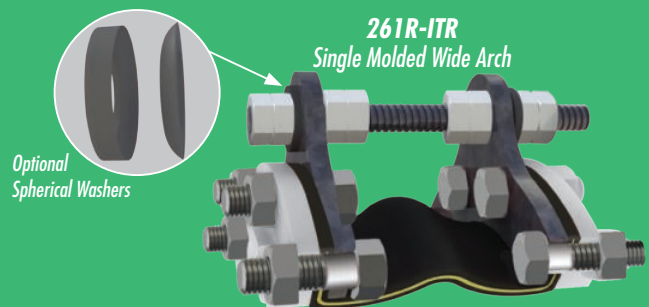


### Un-Anchored System Note:

Rod sets should be installed so that external nuts are snug against the plate at installation. Pressure thrust of the pipe system can cause expansion joint to over-elongate and reduce movement capabilities.

## ALSO AVAILABLE FROM Proco Products, Inc.

Proco Products, Inc. can supply an Integral Tie Rod Design Joint when space prohibits use of typical rod designs.



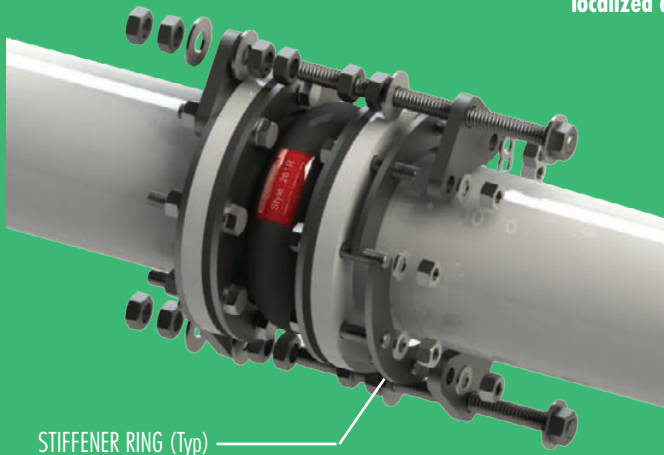
## Series 260R Rubber Expansion Joints installed on Plastic/FRP Piping Systems using Limit/Control Units



Figure 1: Series 261R

The PROCO Series 260R Wide Arch Expansion Joints are specifically designed for use with Plastic or FRP Piping Systems. A replacement for the standard spool-type expansion joints, the PROCO Styles 261R & 262R have exceptionally low spring rates compared to its conventional counterparts. With low forces to compress, extend or laterally offset, the PROCO Series 260R expansion joints can be used on plastic or FRP pipes, pumps, valves or tanks without fear of the expansion joint being stronger than the plastic or FRP pipe, pump, valve or tank flanges.

When pairing the Series 260R expansion joints with standard control units utilizing control/gusset plates, a stiffener ring to reinforce the mating flange is required. Placing the stiffener ring on the back of the mating flange will reinforce the mating flange by more evenly distributing the pressure thrust loads experienced by the control units across the flange in lieu of a standard installation where the loads are localized at the points of contact between the control/gusset plate and flange.



STIFFENER RING (Typ)

Figure 2: Style 261R and Style 262R with Control Units (Inboard and Outboard Nuts)

If stiffener rings are not used, then the allowable stress on the mating flanges need to be confirmed. Not utilizing stiffener rings while using control units adds local stresses on the points of contact between the mating flange and control plates that may surpass the allowable stress for the flange resulting in a possible failure of the mating flange.

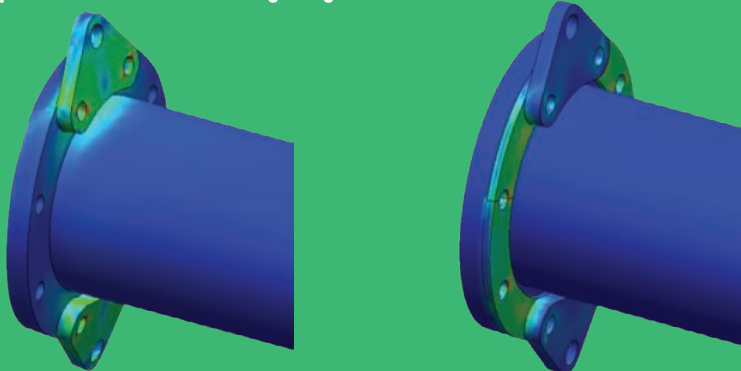


Figure 3: General Stress Plot of Mating Flange without Stiffener Ring (Left), with Stiffener Ring (Right)



2431 North Wigwam Dr. (95205)  
P.O. Box 590 • Stockton, CA  
95201-0590 • USA

Toll-Free Phone: (800) 344-3246

NATIONWIDE AND CANADA

Facsimile: (209) 943-0242



REPRESENTED BY:

**GOODYEAR**  
RUBBER PRODUCTS, INC.

727-342-5088

You can also email us at  
[GRP@goodyearrubberproducts.com](mailto:GRP@goodyearrubberproducts.com)

# PROCO

*The Expansion Joint and Check Valve People*



RUBBER EXPANSION JOINT SERIES 271

**GOODYEAR**  
RUBBER PRODUCTS, INC.

☎ 727-342-5088

You can also email us at  
[GRP@goodyearrubberproducts.com](mailto:GRP@goodyearrubberproducts.com)

# Proco Style 271 Rubber Joints

**Proco Style 271** Rubber Expansion Joints are designed for piping systems to absorb pipe movements, relieve stress, reduce system noise/vibration, compensate for misalignment/offset and to protect rotating mechanical equipment against start-up surge forces.

The Style 271 rubber expansion joint is a single super wide flowing arch design. The wide flowing arch is self-cleaning which makes it a perfect choice for slurries, thus eliminating the need for a filled arch design.

The Style 271 can easily replace and interchange with hand built narrow/wide filled arch, molded wide arch and spherical type expansion joints. Proco's Style 271 has been successfully installed in tough demanding applications such as: Chemical/Petrochemical, Marine, Power Generation, Pulp/Paper, Steel Mills and Water/Wastewater Treatment.

## Features and Benefits:

### Absorbs Directional Movement

Thermal movements appear in any rigid pipe system due to temperature changes. The Style 271 super low profile wide arch allows for axial compression or axial extension, lateral deflection as well as angular and torsional movements. (Note: Rated movements in this publication are based on one plane movements. Multiple movement conditions are based on a multiple movement calculation. Contact Proco for information when designing multiple pipe movements.)

### Less Turbulence or Material Entrapment

The Style 271 expansion joints are manufactured with the integral rubber flange joining the body at a true 90° angle. This ensures the product will install snug against the mating pipe flange free of voids creating less turbulence in the pipe system. The Proco 271 rubber joint also has a self-flushing arch which eliminates media buildup and the need for a filled arch spool joint resulting in greater movement capability and lower spring rates.

### Absorbs Vibration, Noise and Shock

The Proco Style 271 rubber expansion joints effectively dampen and insulate downstream piping against the transmission of noise and vibration generated by mechanical equipment. Noise and vibrations caused by equipment can cause stress in pipe, pipe guides, anchors and other equipment downstream. The Style 271 expansion joints will help relieve noise and vibration occurrences in a pipe system. Water hammer and pumping impulses can also cause strain, stress or shock to a piping system. Install the Style 271 to help compensate for these system pressure spikes.

### Compensates for Misalignment

Rubber expansion joints are commonly used by contractors and plant personnel to allow for slight pipe misalignment during installation of new piping and or replacement applications. (Although rubber expansion joints can be made with permanent offsets, it is suggested that piping misalignments be limited to no more than 1/2 the rated catalog movement. Contact Proco for resultant movement capability.)

### Wide Service Range and Less Weight

Engineered to operate up to 200 PSIG (nominal size dependent) or up to 250°F (elastomer dependent), the Series 271 can be specified for a wide range of piping system requirements. The Series 271 rubber expansion joints are constructed in various elastomers with rubber impregnated polyester tire cord cross wrapped in bias ply construction. This construction eliminates the need for internal wire reinforcement (while still providing adequate pressure and vacuum ratings) making the Series 271 less weight than a typical spool or spherical expansion joint option. This lightweight design installs easily and costs less to ship.

### Material Identification

All 271 expansion joints are strip branded with cure dates and elastomer designations. All Neoprene Tube/Neoprene Cover (NN) and Nitrile Tube/Neoprene Cover (NP) elastomer designated joints meet the Coast Guard Requirements and conform to ASTM F 1123-87.

### Large Inventory

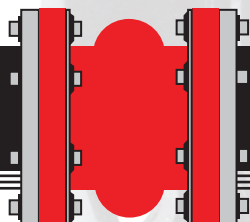
Proco Products, Inc. maintains one of the largest inventories of rubber expansion joints in the world. Please contact us for price and availability.

**Table 1: Available Materials \* Temperatures**

For Specific Chemical Compatibilities, See: PROCO "Chemical To Elastomer Guide"					
Proco Style Number	Cover 1,2 Elastomer	Tube 1,2 Elastomer	Maximum Operating Temp. °F (°C)	Branding Label Color	F.S.A. Material Class
271/BB	Chlorobutyl	Chlorobutyl	250° (121°)	Black	STD. III
271/EE	EPDM	EPDM <sup>5</sup>	250° (121°)	Red	STD. III
271/EQ	EPDM	FDA-EPDM	250° (121°)	Red <sup>3</sup>	STD. II
271/NH	Neoprene	CSM	212° (100°)	Green	STD. II
271/NN	Neoprene	Neoprene <sup>5</sup>	225° (107°)	Blue	STD. II
271/NF	Neoprene	FDA-Neoprene	225° (107°)	Blue <sup>3</sup>	STD. II
271/NP	Neoprene	Nitrile	212° (100°)	Yellow	STD. II
271/NR	Neoprene	Natural Rubber	180° (82°)	White	STD. I

**Protecting Piping and Equipment Systems from Stress/Motion**

Information subject to change without notice.



Notes: All Products are reinforced with Polyester Tire Cord

1. Expansion Joint "Cover" can be coated with CSM UV

3. Branding Label will be marked as "Food Grade".

4. All elastomers above are not intended for steam service

# Style 271 Performance Data

**Table 2: Sizes • Movements • Design Pressures • Weights**

Expansion Joint Size Nom. I.D. Inch / (mm)		Neutral Length Inch / (mm)		271 Movement Capability: From Neutral Position (Non-Concurrent)					Operating Conditions <sup>1</sup>			Weights lbs / (kgs) <sup>2</sup>			
				Axial Compression Inch / (mm)	Axial Extension Inch / (mm)	Lateral Deflection Inch / (mm)	Angular Deflection <sup>3</sup> (Degrees)	Torsional Rotation <sup>4</sup> (Degrees)	Thrust Factor <sup>5</sup> In <sup>2</sup> / (cm <sup>2</sup> )	Positive PSIG (Bar)	Vacuum Inches of Hg / (mm of Hg) <sup>6</sup>	Expansion Joint	Retaining Ring Set	Limit Rod Assembly <sup>7</sup>	
2	(50)	6	152												
		7	178												
		8	203	1.0	0.5	0.5	25	2	7.94	200	26	3.5	4.0	2.8	
		9	229	(25)	(13)	(13)			(51)	(14)	(660)	(1.6)	(1.8)	(1.3)	
		10	254												
		12	305												
2.5	(65)	6	152												
		7	178												
		8	203	1.0	0.5	0.5	20	2	10.63	200	26	3	4.5	2.8	
		9	229	(25)	(13)	(13)			(69)	(14)	(660)	(1.3)	(2.0)	(1.3)	
		10	254												
		12	305												
3	(80)	6	152												
		7	178												
		8	203	1.0	0.5	0.5	17	2	13.72	200	26	3	5.5	2.8	
		9	229	(25)	(13)	(13)			(89)	(14)	(660)	(1.4)	(2.5)	(1.3)	
		10	254												
		12	305												
4	(100)	6	152												
		7	178												
		8	203	1.0	0.5	0.5	13	2	21.06	200	26	4.0	8.0	2.8	
		9	229	(25)	(13)	(13)			(136)	(14)	(660)	(2.0)	(3.6)	(1.3)	
		10	254												
		12	305												
5	(125)	6	152												
		7	178												
		8	203	1.0	0.5	0.5	10	2	29.98	190	26	6.0	8.5	4.0	
		9	229	(25)	(13)	(13)			(193)	(13)	(660)	(2.6)	(3.9)	(1.8)	
		10	254												
		12	305												
6	(150)	6	152												
		7	178												
		8	203	1.0	0.5	0.5	8	2	40.47	190	26	6.0	9.5	4.0	
		9	229	(25)	(13)	(13)			(261)	(13)	(660)	(2.8)	(4.3)	(1.8)	
		10	254												
		12	305												

# Style 271 Performance Data

**Table 2: Sizes • Movements • Design Pressures • Weights**

Expansion Joint Size Nom. I.D. Inch / (mm)	Neutral Length Inch / (mm)	271 Movement Capability: From Neutral Position (Non-Concurrent)					Operating Conditions <sup>1</sup>			Weights lbs / (kgs) <sup>2</sup>				
		Axial Compression Inch / (mm)	Axial Extension Inch / (mm)	Lateral Deflection Inch / (mm)	Angular Deflection <sup>3</sup> (Degrees)	Torsional Rotation <sup>4</sup> (Degrees)	Thrust Factor <sup>5</sup> In <sup>2</sup> / (cm <sup>2</sup> )	Positive PSIG (Bar)	Vacuum Inches of Hg / (mm of Hg) <sup>6</sup>	Expansion Joint	Retaining Ring Set	Limit Rod Assembly <sup>7</sup>		
8	(200)	6	152											
		7	178											
		8	203	1.0	0.5	0.5	6	2	66.15	190	26	9.0	14.5	8.0
		9	229	(25)	(13)	(13)			(427)	(13)	(660)	(4.1)	(6.6)	(3.6)
		10	254											
10	(250)	12	305											
		8	203											
		9	229	1.2	0.5	0.5	5	2	105.27	190	26	18.0	17.0	10.0
10	(250)	10	254	(30)	(13)	(13)			(679)	(13)	(660)	(8.1)	(7.7)	(4.5)
		12	305											
		8	203											
12	(300)	9	229	1.2	0.5	0.5	4	2	144.77	190	26	20.0	24.5	10.0
		10	254	(30)	(13)	(13)			(934)	(13)	(660)	(9.1)	(11.1)	(4.5)
		12	305											
		8	203											
14	(350)	9	229	1.2	0.5	0.5	3	2	190.55	130	26	23.0	27.0	12.0
		10	254	(30)	(13)	(13)			(1229)	(9)	(660)	(10.3)	(12.2)	(5.5)
		12	305											
		8	203											
16	(400)	9	229	1.2	0.5	0.5	3	2	242.61	115	26	27.0	33.5	15.0
		10	254	(30)	(13)	(13)			(1565)	(8)	(660)	(12.0)	(15.2)	(6.8)
		12	305											
		8	203											
18	(450)	10	254	1.2	0.5	0.5	3	2	300.95	115	26	30.0	34.0	16.0
		12	305	(30)	(13)	(13)			(1942)	(8)	(660)	(13.4)	(15.4)	(7.3)
		8	203											
20	(500)	10	254	1.2	0.5	0.5	2	2	365.57	115	26	36.0	38.0	16.0
		12	305	(30)	(13)	(13)			(2359)	(8)	(660)	(16.3)	(17.2)	(7.3)
		8	203											
22	(550)	10	254	1.2	0.5	0.5	2	2	436.47	110	26	41.0	44.0	19.0
		12	305	(30)	(13)	(13)			(2816)	(8)	(660)	(18.7)	(20)	(9)
24	(600)	10	254	1.2	0.5	0.5	2	2	513.65	110	26	44.5	48.0	20.0
		12	305	(30)	(13)	(13)			(3314)	(8)	(660)	(20.2)	(21.8)	(9.1)
26	(650)	10	254	1.2	0.5	0.5	2	2	597.12	90	26	48.0	51.0	20.0
		12	305	(30)	(13)	(13)			(3853)	(6)	(660)	(21.8)	(23.1)	(9.1)
28	(700)	10	254	1.2	0.5	0.5	2	2	686.86	90	26	53.0	55.0	28.0
		12	305	(30)	(13)	(13)			(4432)	(6)	(660)	(23.9)	(24.9)	(12.7)
		10	254	1.2	0.5	0.5			782.88	90	18	60.0	63.0	29.5

**Table 2: Sizes • Movements • Design Pressures • Weights**

Expansion Joint Size Nom. I.D. Inch / (mm)		Neutral Length Inch / (mm)	271 Movement Capability: <sup>1</sup> From Neutral Position (Non-Concurrent)					Operating Conditions <sup>2</sup>			Weights lbs / (kgs) <sup>3</sup>			
			Axial Compression Inch / (mm)	Axial Extension Inch / (mm)	Lateral Deflection Inch / (mm)	Angular Deflection <sup>4</sup> (Degrees)	Torsional Rotation <sup>5</sup> (Degrees)	Thrust Factor <sup>6</sup> In <sup>2</sup> / (cm <sup>2</sup> )	Positive PSIG (Bar)	Vacuum Inches of Hg / (mm of Hg) <sup>7</sup>	Expansion Joint	Retaining Ring Set	Limit Rod Assembly <sup>8</sup>	
<b>32</b>	(800)	<b>10</b>	254	1.2	0.5	0.5	1	2	885.18	90	18	65.0	68.0	29.5
		<b>12</b>	305	(30)	(13)	(13)			(5711)	(6)	(450)	(29.3)	(30.8)	(13.4)
<b>34</b>	(850)	<b>10</b>	254	1.2	0.5	0.5	1	2	993.76	90	18	72.0	72.0	43.0
		<b>12</b>	305	(30)	(13)	(13)			(6412)	(6)	(450)	(32.8)	(32.7)	(19.5)
<b>36</b>	(900)	<b>10</b>	254	1.2	0.5	0.5	1	1	1108.62	90	18	79.0	76.0	43.0
		<b>12</b>	305	(30)	(13)	(13)			(7153)	(6)	(450)	(36)	(34.5)	(19.5)
<b>38</b>	(950)	<b>10</b>	254	1.2	0.5	0.5	1	1	1229.76	90	18	85.5	86.0	43.0
		<b>12</b>	305	(30)	(13)	(13)			(7934)	(6)	(450)	(38.8)	(39.0)	(19.5)
<b>40</b>	(1000)	<b>10</b>	254	1.2	0.5	0.5	1	1	1357.18	90	18	91.0	100.0	43.0
		<b>12</b>	305	(30)	(13)	(13)			(8757)	(6)	(450)	(41.3)	(45.4)	(19.5)
<b>42</b>	(1050)	<b>12</b>	305	1.4	0.5	0.5	1	1	1507.35	80	15	112.0	100.0	44.0
		<b>14</b>	356	(36)	(13)	(13)			(9725)	(5.5)	(380)	(50.8)	(45.4)	(20)
<b>44</b>	(1100)	<b>12</b>	305	1.4	0.5	0.5	1	1	1648.09	80	15	123.0	104.0	44.0
		<b>14</b>	356	(36)	(13)	(13)			(10633)	(5.5)	(380)	(55.6)	(47.2)	(20)
<b>46</b>	(1150)	<b>12</b>	305	1.4	0.5	0.5	1	1	1795.10	80	15	130.0	127.0	44.0
		<b>14</b>	356	(36)	(13)	(13)			(11582)	(5.5)	(380)	(58.8)	(57.6)	(20)
<b>48</b>	(1200)	<b>12</b>	305	1.4	0.5	0.5	1	1	1948.40	80	15	139.0	132.0	44.0
		<b>14</b>	356	(36)	(13)	(13)			(12571)	(5.5)	(380)	(62.9)	(59.9)	(20)

**NOTES:**

1. Concurrent Movements - Concurrent movements are developed when two or more movements in a pipe system occur at the same time.

If multiple movements exceed single arch design there may be a need for additional arches.

To perform calculation for concurrent movement when a pipe system design has more than one movement, please use the following formula:

$$\frac{\text{Actual Axial Compression} + \text{Actual Axial Extension} + \text{Actual Lateral (X)} + \text{Actual Lateral (Y)}}{\text{Rated Axial Compression} + \text{Rated Axial Extension} + \text{Rated Lateral (X)} + \text{Rated Lateral (Y)}} = / < 1$$

Calculation must be equal to or less than 1 for expansion joint to operate within concurrent movement capability.

2. Pressure rating is based on 170° F operating temperature with a 4:1 safety factor. At higher temperatures, the pressure rating is reduced slightly.

Hydrostatic testing at 1.5 times rated maximum catalogue pressure or design working pressure of pipe system for 10 minutes is available upon request.

3. Weights are approximate and vary due to length.

4. The degree of angular movement is based on the maximum rated extension.

5. Torsional movement is expressed when the expansion joint is at neutral length.

6. Calculation of Thrust (Thrust Factor). When expansion joints are installed in the pipeline, the static portion of the thrust is calculated as a product of the area of the I.D. of the arch of the expansion joint times the maximum pressure (design, test or surge) that will occur in the line. The result is a force expressed in pounds.

Take Design, surge or test pressure X thrust factor to calculate end thrust.

7. Parts listed at 26" Hg / 660 mm Hg vacuum have a design rating of 30" Hg / 762 mm Hg (full vacuum). Vacuum rating is based on neutral installed length, without external load. Products should not be installed "extended" on vacuum applications.

8. Limit rod unit weight consists of one rod with washers, nuts and two limit rod plates. Multiply number of limit rods needed for the application (as specified in the Fluid Sealina Association's Technical Handbook 7.3 Edition or table 4 in this manual) to determine correct weights

**"Effective Area"**

Thrust Factor=

$$T = \frac{\pi}{4} (D)^2 (P)$$

T= Thrust  
P= PSI (Design, Test or Surge)  
D= Arch I.D.

# Style 271 Drilling Chart

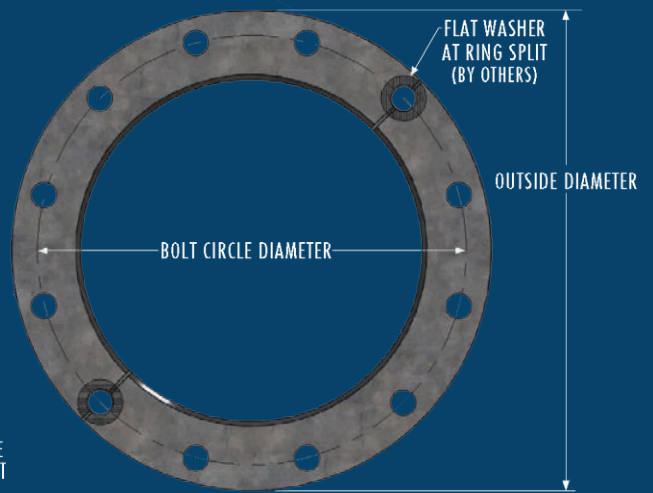
Table 3		Standard Drilling for PROCO Rubber Expansion Joints				Thickness of Materials for PROCO Rubber Expansion Joints						Control Unit Plate Detail						
Nominal Pipe Size Expansion Joint I.D. Inch / (mm)	Flange Dimensions <sup>2</sup>				Material Thickness <sup>1</sup> for Bolt Length Requirements						Control Unit Plate Detail							
	Flange O.D. Inch / (mm)		Bolt Circle Inch / (mm)		Number Of Holes	Size Of Holes Inch / (mm)		Retaining Rings Thickness Inch / (mm)		Rubber Flange Thickness Inch / (mm)		Adjacent <sup>3</sup> Mating Flange Thickness	Max. Control <sup>4</sup> Rod Plate Thickness Inch / (mm)		Control Rod <sup>6</sup> Plate O.D. Inch / (mm)		Maximum <sup>7</sup> Rod Diameter Inch / (mm)	
2	(50)	6.00	(152.40)	4.75	(120.65)	4	0.750	(19.05)	0.375	(9.53)	0.472	(11.99)	0.375	(9.53)	10.125	(257.2)	0.625	(15.9)
2.5	(65)	7.00	(177.80)	5.50	(139.70)	4	0.750	(19.05)	0.375	(9.53)	0.472	(11.99)	0.375	(9.53)	11.125	(282.6)	0.625	(15.9)
3	(80)	7.50	(190.50)	6.00	(152.40)	4	0.750	(19.05)	0.375	(9.53)	0.472	(11.99)	0.375	(9.53)	11.625	(295.3)	0.625	(15.9)
4	(100)	9.00	(228.60)	7.50	(190.50)	8	0.750	(19.05)	0.375	(9.53)	0.472	(11.99)	0.375	(9.53)	13.125	(333.4)	0.625	(15.9)
5	(125)	10.00	(254.00)	8.50	(215.90)	8	0.875	(22.23)	0.375	(9.53)	0.551	(14.00)	0.500	(12.70)	14.125	(358.8)	0.625	(15.9)
6	(150)	11.00	(279.40)	9.50	(241.30)	8	0.875	(22.23)	0.375	(9.53)	0.551	(14.00)	0.500	(12.70)	15.125	(384.2)	0.625	(15.9)
8	(200)	13.50	(342.90)	11.75	(298.45)	8	0.875	(22.23)	0.375	(9.53)	0.630	(16.00)	0.750	(19.05)	19.125	(485.8)	1.000	(25.4)
10	(250)	16.00	(406.40)	14.25	(361.95)	12	1.000	(25.40)	0.375	(9.53)	0.630	(16.00)	0.750	(19.05)	21.625	(549.3)	1.000	(25.4)
12	(300)	19.00	(482.60)	17.00	(431.80)	12	1.000	(25.40)	0.375	(9.53)	0.748	(19.00)	0.750	(19.05)	24.625	(625.5)	1.000	(25.4)
14	(350)	21.00	(533.40)	18.75	(476.25)	12	1.125	(28.58)	0.375	(9.53)	0.866	(22.00)	0.750	(19.05)	26.625	(676.3)	1.000	(25.4)
16	(400)	23.50	(596.90)	21.25	(539.75)	16	1.125	(28.58)	0.375	(9.53)	0.866	(22.00)	0.750	(19.05)	30.125	(765.2)	1.250	(31.8)
18	(450)	25.00	(635.00)	22.75	(577.85)	16	1.250	(31.75)	0.375	(9.53)	0.866	(22.00)	0.750	(19.05)	31.625	(803.3)	1.250	(31.8)
20	(500)	27.50	(698.50)	25.00	(635.00)	20	1.250	(31.75)	0.375	(9.53)	0.984	(24.99)	0.750	(19.05)	34.125	(866.8)	1.250	(31.8)
22	(550)	29.50	(749.30)	27.25	(692.15)	20	1.375	(34.93)	0.375	(9.53)	0.984	(24.99)	1.000	(25.40)	36.125	(917.6)	1.250	(31.8)
24	(600)	32.00	(812.80)	29.50	(749.30)	20	1.375	(34.93)	0.375	(9.53)	0.984	(24.99)	1.000	(25.40)	38.625	(981.1)	1.250	(31.8)
26	(650)	34.25	(869.95)	31.75	(806.32)	24	1.375	(34.93)	0.375	(9.53)	0.984	(24.99)	1.000	(25.40)	40.875	(1038.2)	1.250	(31.8)
28	(700)	36.50	(927.10)	34.00	(863.60)	28	1.375	(34.93)	0.375	(9.53)	0.984	(24.99)	1.250	(31.75)	44.125	(1120.8)	1.500	(38.1)
30	(750)	38.75	(984.25)	36.00	(914.40)	28	1.375	(34.93)	0.375	(9.53)	0.984	(24.99)	1.250	(31.75)	46.375	(1177.9)	1.500	(38.1)
32	(800)	41.75	(1060.45)	38.50	(977.90)	28	1.625	(41.28)	0.375	(9.53)	0.984	(24.99)	1.250	(31.75)	49.375	(1254.1)	1.500	(38.1)
34	(850)	43.75	(1111.25)	40.50	(1028.70)	32	1.625	(41.28)	0.375	(9.53)	0.984	(24.99)	1.500	(38.10)	52.375	(1330.3)	1.750	(44.5)
36	(900)	46.00	(1168.40)	42.75	(1085.85)	32	1.625	(41.28)	0.375	(9.53)	0.984	(24.99)	1.500	(38.10)	54.625	(1387.5)	1.750	(44.5)
38	(950)	48.75	(1238.25)	45.25	(1149.35)	32	1.625	(41.28)	0.375	(9.53)	0.984	(24.99)	1.500	(38.10)	57.375	(1457.3)	1.750	(44.5)
40	(1000)	50.75	(1289.05)	47.25	(1200.15)	36	1.625	(41.28)	0.375	(9.53)	0.984	(24.99)	1.500	(38.10)	58.375	(1482.7)	1.750	(44.5)
42	(1050)	53.00	(1346.20)	49.50	(1257.30)	36	1.625	(41.28)	0.375	(9.53)	1.181	(30.00)	1.500	(38.10)	61.625	(1565.3)	1.750	(44.5)
44	(1100)	55.25	(1403.35)	51.75	(1314.45)	40	1.625	(41.28)	0.375	(9.53)	1.181	(30.00)	1.500	(38.10)	63.875	(1622.4)	1.750	(44.5)
46	(1150)	57.25	(1454.15)	53.75	(1365.25)	40	1.625	(41.28)	0.375	(9.53)	1.181	(30.00)	1.500	(38.10)	65.875	(1673.2)	1.750	(44.5)
48	(1200)	59.50	(1511.30)	56.00	(1422.40)	44	1.625	(41.28)	0.375	(9.53)	1.181	(30.00)	1.500	(38.10)	68.125	(1730.4)	1.750	(44.5)

Metric Conversion Formula: Nominal I.D.: in. x 25 = mm; Dimensions/Thickness': in. x 25.4 = mm.

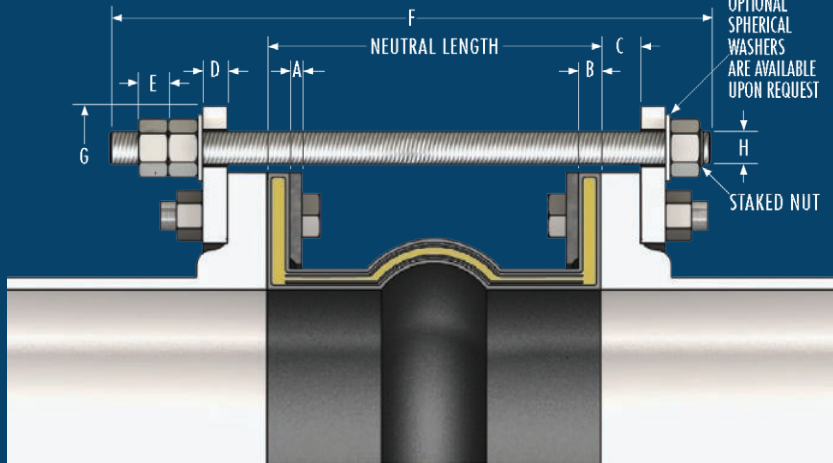
**Notes:**

1. Limit/Control Rod length is determined by neutral length of rubber expansion joint, rated extension, control rod plate thickness, mating flange thickness and number of nuts. Consult PROCO for rod lengths.
2. Flange Dimensions shown are in accordance with ANSI B16.1 and ANSI B16.5 Class 125/150, AWWA C-207-07, Tbl 2 and 3 - Class D, Table 4 - Class E. Hole size shown is 1/8" larger than AWWA Standard.
3. Adjacent mating flange thickness is required to determine overall rod length and compression sleeve length (if required).
4. Plate thickness is based on a maximum width PROCO would use to design a Limit/Control Rod plate.

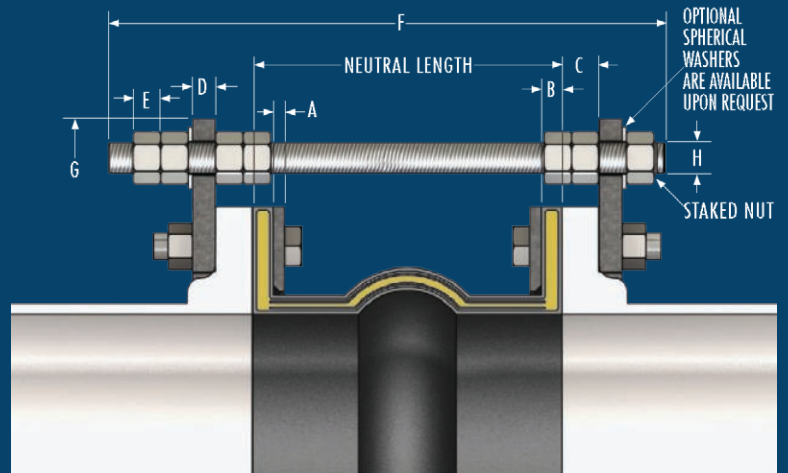
- A** - Retaining Ring Thickness.
- B** - Rubber Flange Thickness.
- C** - Adjacent Mating Flange Thickness (By Others).
- D** - Control Unit Plate Thickness.
- E** - Double Nut Thickness is determined by Control Rod Diameter.
- F** - Control Rod Bolt Length is determined by A through E + OAL <sup>1</sup>.
- G** - Control Rod Control Rod Plate O.D.
- H** - Maximum Rod Diameter



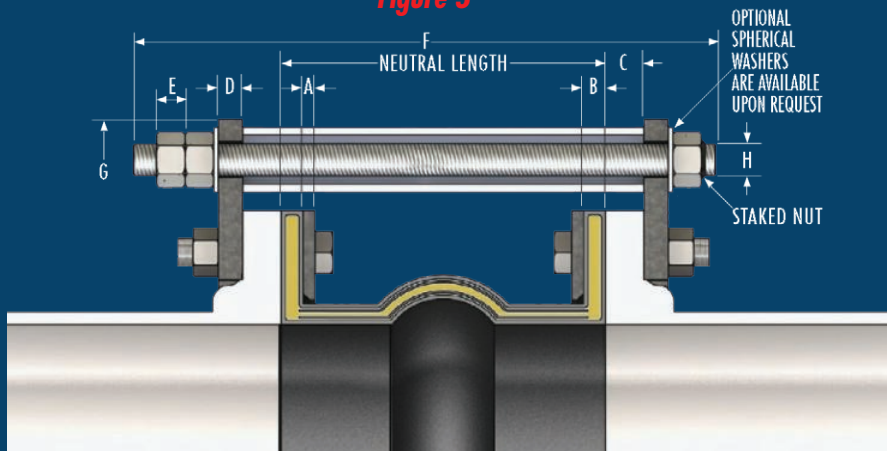
**Figure 1**



**Figure 2**



**Figure 3**



# Limit Rods, Control Rods & Compression Sleeves

## Use of Control Units with Rubber Expansion Joints

### Definition

A control unit assembly is a system of two or more control rod units (limit rods, tie rods or compression sleeves) placed across an expansion joint from flange to flange to minimize possible damage caused by excessive motion of a pipeline. The control unit assemblies can be set at the maximum allowable expansion and/or contraction of the rubber expansion joint. When used in this manner, control units are an additional safety factor and can minimize possible damage to adjacent equipment.

Rubber expansion joints should be installed between two fixed anchor points in a piping system. The pipe system must be rigidly anchored on both sides of the expansion joint to control expansion or contraction of the line. Piping anchors must be capable of withstanding the line thrusts generated by internal pressure or wide temperature fluctuations.

When proper anchoring cannot be provided, **CONTROL UNITS ARE REQUIRED**. For un-anchored piping systems nuts shall be tightened snug against rod plate to prevent over extension due to pressure thrust created by expansion joint. Refer to "Thrust Factor in Table 2, note 5 in this manual.

Listed below are three (3) control unit configurations supplied by PROCO and are commonly used with rubber expansion joints in piping systems.

### Figure 1

Known as a **LIMIT ROD**, this control unit configuration will allow an expansion joint to extend to a predetermined extension setting. Nuts shall be field set to no more than the maximum allowable extension movement of a rubber expansion joint (unless used in an un-anchored system). Refer to Table 2 in this manual for allowable movement capabilities. Spherical washers can also be furnished (upon request) to combat any "nut to plate" binding during offset. **Consult the systems engineer for proper nut settings prior to system operation.**

### Figure 2

Known as a **LIMIT/CONTROL ROD**, this control unit configuration is used to allow specified pipe expansion (expansion joint axial compression) and pipe contraction (expansion joint axial extension) movements. Nuts shall be field set to no more than the maximum allowable extension (unless used in an un-anchored pipe system) or compression of a rubber expansion joint. Refer to Table 2 in this manual for allowable movement capabilities. Internal and external nuts can also be field set to allow for no movement in the horizontal plane. This setting will allow the rubber to move laterally while keeping expansion joint thrust forces low on adjacent equipment. Spherical washers can also be furnished (upon request) to combat any potential "nut to plate" binding during offset. **Limit/Control rods with internal nuts must be specified at the time of inquiry. Consult the systems engineer for proper nut settings prior to system operation.**

### Figure 3

Known as a **COMPRESSION SLEEVE**, this configuration is used to allow for specified pipe expansion (expansion joint axial compression) and pipe contraction (expansion joint extension) movements. Nuts shall be field set to no more than the maximum allowable extension (unless used in an un-anchored pipe system) of a rubber expansion joint. Refer to Table 2 in this manual for allowable movement capabilities. PROCO will manufacture each compression sleeve to allow for no axial movement unless otherwise specified by the purchaser. Compression sleeves shall be field trimmed to meet required allowable axial movement as set forth by system requirements. Spherical washers can also be furnished (upon request) to combat any potential "nut to plate" binding during offset. **Consult the systems engineer for proper sleeve lengths prior to system operation.**

### Important Control Unit Considerations

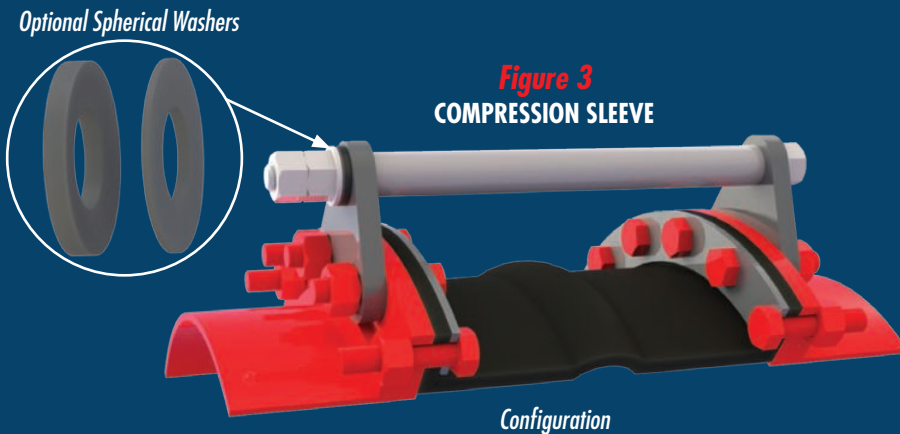
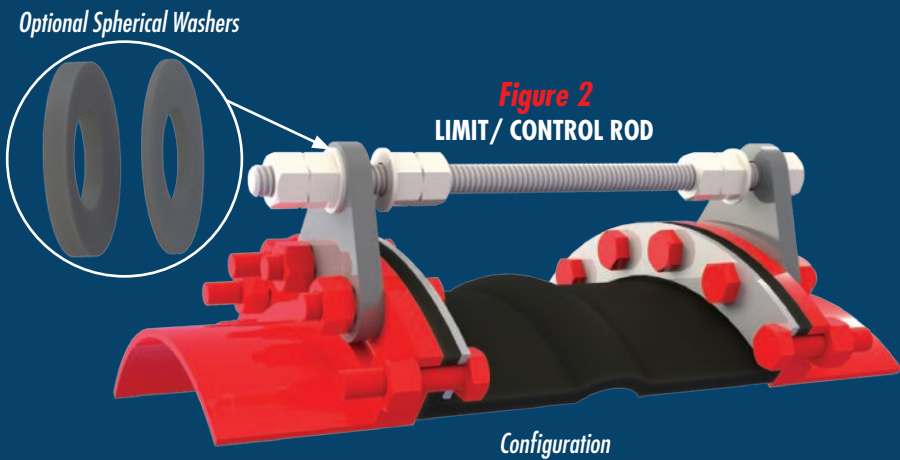
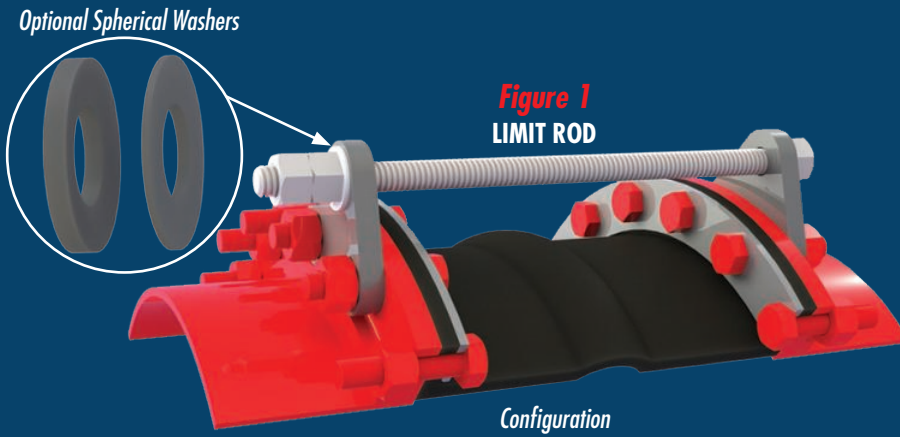
The number of rods, control rod diameters and control rod plate thicknesses are important considerations when specifying control units for an application. As a minimum, specifying engineers or purchasers shall follow the guidelines as set forth in Appendix C of the Fluid Sealing Association's Technical Handbook, 7.3 Edition. PROCO engineers its control unit assemblies to system requirements. Our designs incorporate an allowable stress of 65% of material yield for each rod and plate (rod and plate material to be specified by purchaser). Therefore, it is important to provide pressure and temperature ratings to PROCO when requesting control units for rubber expansion joints. It is also important to provide adjacent mating flange thickness or mating

### Installation Instructions for Control Rods

1. Assemble expansion joint between pipe flanges in its manufactured face-to-face length. Install the retaining rings furnished with the expansion joint.
2. Assemble control rod plates behind pipe flanges as shown. Flange bolts or all thread studs through the control rod plate must be longer to accommodate the plate thickness. Control rod plates should be equally spaced around the flange. Depending upon the size and pressure rating of the system, 2, 3, 4, or more control/limit rods may be required. Refer to Table 4 in this manual or to the Fluid Sealing Association's Technical Handbook, 7.3 Edition, page 23 for control rod pressure ratings.
3. Insert control/limit rods through top plate holes. Steel flat washers are to be positioned at outer plate surface.
4. If a single nut per unit is furnished, position this nut so that there is a gap between the nut and the steel flat washer. This gap is equal to the joints maximum extension (commencing with the nominal face-to-face length). To lock this nut in position, either "stake" the thread in two places or tack weld the nut to the rod. If two nuts are supplied, the nuts will create a "jamming" effect to prevent loosening. (Nuts should be snug against flat washer and control rod plate when piping system is un-anchored.)

*Note: Consult the manufacturer if there are any questions as to the rated compression and elongation. These two dimensions are critical in setting the nuts and sizing the compression pipe sleeve (if supplied).*

5. If there is a requirement for compression pipe sleeves, ordinary pipe may be used, sized in length to allow the joint to be compressed to its normal limit.
6. If there is a requirement for optional spherical washers, these washers are to be positioned at outer plate surface and backed



<b>Table 4</b>		<b>Maximum Surge or Test Pressure of the Systems</b>			
<b>Nominal Pipe Size Expansion Joint I.D.</b>	<b>Inch / (mm)</b>	<b>Number of Control Rods Recommended</b>			
		<b>2</b>	<b>4</b>	<b>6</b>	<b>8</b>
<b>2</b>	(50)	661	•	•	•
<b>2.5</b>	(65)	529	•	•	•
<b>3</b>	(75)	441	•	•	•
<b>4</b>	(100)	311	622	•	•
<b>5</b>	(125)	235	470	•	•
<b>6</b>	(150)	186	371	•	•
<b>8</b>	(200)	163	326	•	•
<b>10</b>	(250)	163	325	488	•
<b>12</b>	(300)	160	320	481	•
<b>14</b>	(350)	112	223	335	•
<b>16</b>	(400)	113	227	340	453
<b>18</b>	(450)	94	187	281	375
<b>20</b>	(500)	79	158	236	315
<b>22</b>	(550)	85	171	256	342
<b>24</b>	(600)	•	147	221	294
<b>26</b>	(650)	•	124	186	248
<b>28</b>	(700)	•	130	195	261
<b>30</b>	(750)	•	141	211	281
<b>32</b>	(800)	•	125	188	251
<b>34</b>	(850)	•	143	215	286
<b>36</b>	(900)	•	138	207	276
<b>38</b>	(950)	•	125	188	251
<b>40</b>	(1000)	•	85	127	169
<b>42</b>	(1050)	•	96	144	192
<b>44</b>	(1100)	•	88	133	177
<b>46</b>	(1150)	•	82	122	163
<b>48</b>	(1200)	•	81	121	161

*Notes:*

1. Pressures listed above do not relate to the actual design pressure of the expansion joint products, but are the maximum surge or pressure for a specific control rod nominal pipe size.

# Installation Instructions for Non-Metallic Expansion Joints

## 1. Service Conditions:

Make sure the expansion joint rating for temperature, pressure, vacuum and movements match the system requirements. Contact the manufacturer for advice if the system requirements exceed those of the expansion joint selected. Check to make sure the elastomer selected is chemically compatible with the process fluid or gas.

## 2. Alignment:

Expansion joints are normally not designed to make up for piping misalignment errors. Piping should be lined up within 1/8". Misalignment reduces the rated movements of the expansion joint and can induce severe stress and reduce service life. Pipe guides should be installed to keep the pipe aligned and to prevent undue displacement.

## 3. Anchoring:

Solid anchoring is required wherever the pipeline changes direction and expansion joints should be located as close as possible to anchor points. If piping is not adequately anchored, control rods should be used. If anchors are not used, pressure thrust may cause excessive movement damaging the expansion joint.

## 4. Pipe Support:

Piping must be supported by hangers or anchors so expansion joints do not carry any pipe weight.

## 5. Mating Flanges:

Install the expansion joint against the mating pipe flanges and install bolts so that the bolt head and washer are against the retaining rings. If washers are not used, flange leakage can result — particularly at the split in the retaining rings. Flange-to-flange dimension of the expansion joint must match the breach opening. Make sure the mating flanges are clean and are flat faced type or no more than 1/16" raised face type. Never install expansion joints that utilize split retaining rings next to wafer type check or butterfly valves. Serious damage can result to a rubber joint of this type unless installed against full face flanges.

## 6. Bolting Torque:

Table 5 shows the recommended torque ranges for non-metallic expansion joints with full-faced rubber flanges: Torque specifications are approximate. Tighten bolts in stages using cross-bolt tightening pattern. If the joint has integral fabric and rubber flanges, the bolts should be tight enough to make the rubber flange OD bulge between the retaining rings and the mating flange. After installation, the system should be pressurized and examined to confirm a proper seal. Torque bolts sufficiently to assure leak free operation at hydrostatic test pressure. *Note: Torque values are approximate due to mating flange surfaces, installation offsets, operating pressures and environmental conditions.*

Table 5 Size	Approximate Torque Values
1" THRU 2"	20 - 40 ft/lbs
2.5" THRU 5"	25 - 60 ft/lbs
6" THRU 12"	35 - 140 ft/lbs
14" THRU 18"	50 - 180 ft/lbs
20" THRU 24"	60 - 200 ft/lbs
26" THRU 40"	70 - 300 ft/lbs
42" THRU 48"	80 - 300 ft/lbs

## 7. Storage:

Ideal storage is in a warehouse with a relatively dry, cool location. Store flanges face down on a pallet or wooden platform. Do not store other heavy items on top of expansion joints. Ten year shelf life can be expected with ideal conditions. If storage must be outdoors, place on wooden platform and joints should not be in contact with the ground. Cover with a tarpaulin.

## 8. Large Joint Handling:

Do not lift with ropes or bars through the bolt holes. If lifting through the bore, use padding or a saddle to distribute the weight. Make sure cables or forklift tines do not contact the rubber. Do not let expansion joints sit vertically on the edges of the flanges for any period of time.

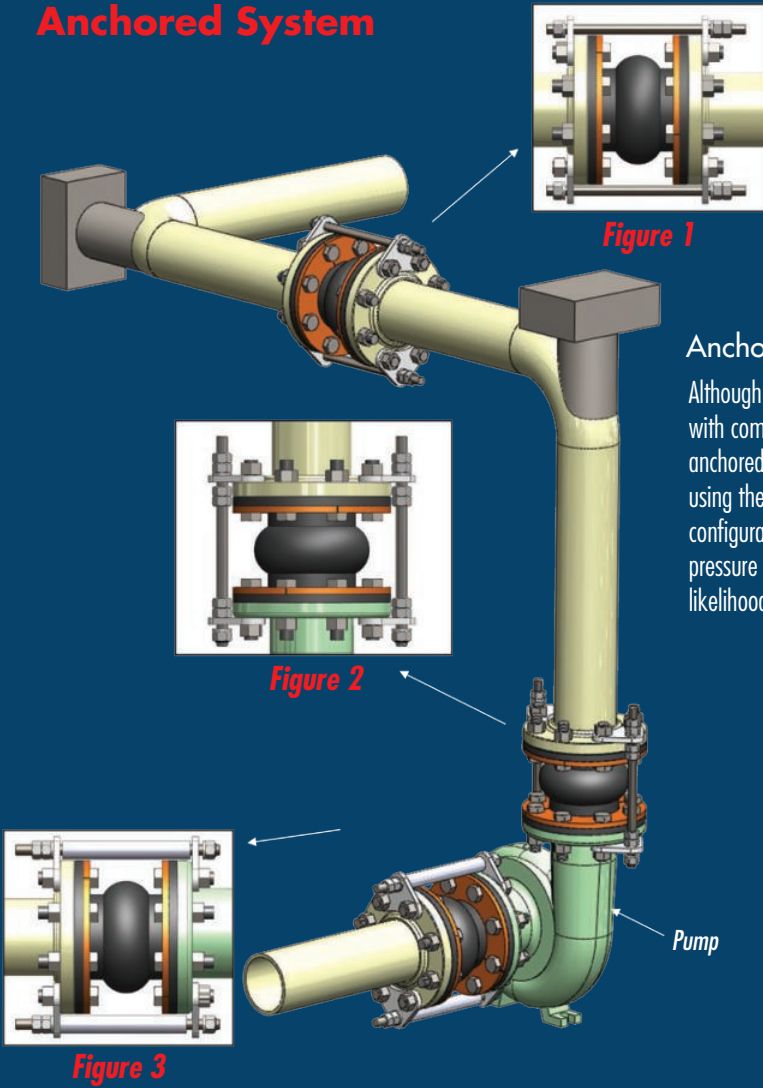
## 9. Additional Tips:

- Do not insulate over a non-metallic expansion joint; however, if insulation is required, it should be made removable to permit easy access to the flanges. This facilitates periodic inspection of the tightness of the joint bolting.
- It is acceptable (but not necessary) to lubricate the expansion joint flanges with a thin film of graphite dispersed in glycerin or water to ease disassembly at a later time.
- Do not weld in the near vicinity of a non-metallic joint.
- If expansion joints are to be installed underground, or will be submerged in water, contact manufacturer for specific recommendations.
- If the expansion joint will be installed outdoors, make sure the cover material will withstand ozone, sunlight, etc.
- Check the tightness of lead-free flanges two or three weeks after installation and retighten if necessary.

*Warning: Expansion joints may operate in pipelines or equipment carrying fluids and/or gases at elevated temperature and pressures and may transport hazardous materials. Precautions should be taken to protect personnel in the event of leakage or splash. Rubber joints should not be installed in areas where inspection is*

# Piping System Layout Examples

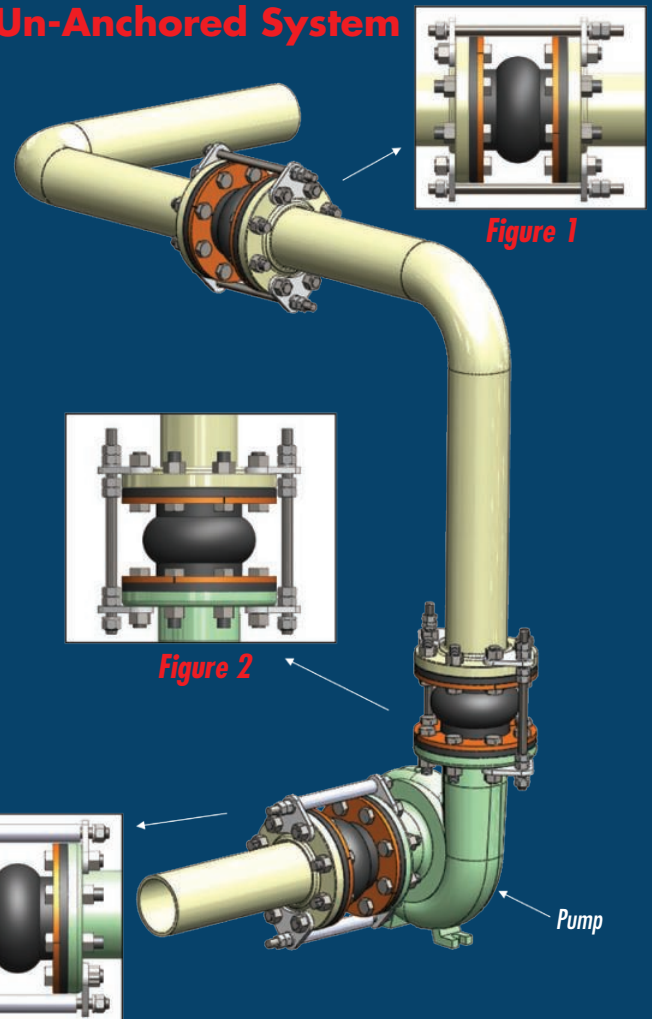
## Anchored System



### Anchored System Note:

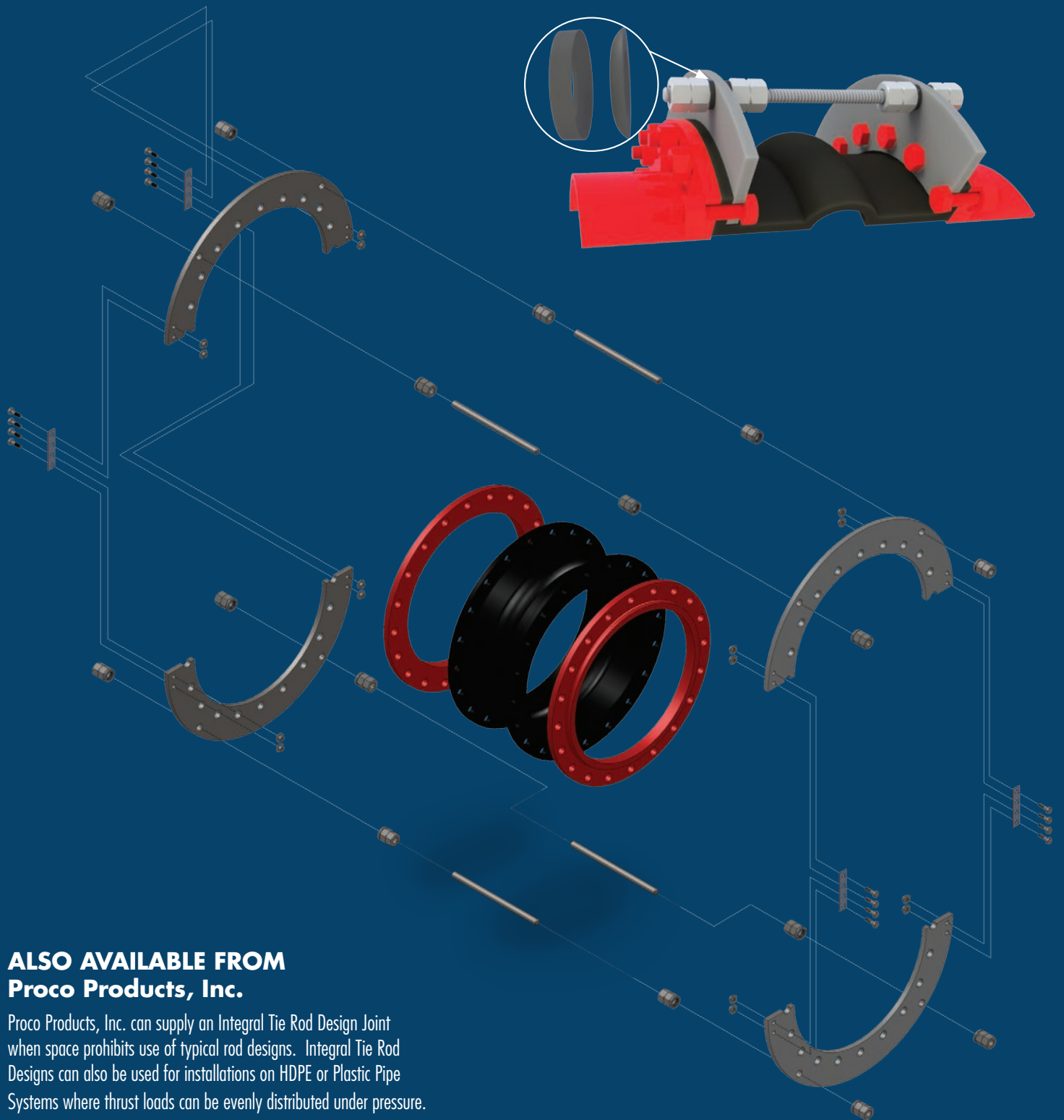
Although limit rods, control rods or limit rods with compression sleeves are not required in an anchored pipe system, you may want to consider using them. If an anchor were to fail, any rod configuration would be capable of handling the pressure thrust of the system and lessen the likelihood of an expansion joint failure.

## Un-Anchored System



### Un-Anchored System Note:

Rod sets should be installed so that external nuts are snug against the plate at installation. Pressure thrust of the pipe system can cause expansion joint to over-elongate and reduce movement capabilities.



**ALSO AVAILABLE FROM  
Proco Products, Inc.**

Proco Products, Inc. can supply an Integral Tie Rod Design Joint when space prohibits use of typical rod designs. Integral Tie Rod Designs can also be used for installations on HDPE or Plastic Pipe Systems where thrust loads can be evenly distributed under pressure.



2431 North Wigwam Dr. (95205)  
P.O. Box 590 • Stockton, CA  
95201-0590 • USA



Toll-Free Phone: (800) 344-3246

Facsimile: (209) 943-0242

**NATIONWIDE AND CANADA**



**REPRESENTED BY:**



**GOODYEAR**  
RUBBER PRODUCTS, INC.

**727-342-5088**

You can also email us at  
**GRP@goodyearrubberproducts.com**

# PROCO

*The Expansion Joint and Check Valve People*



EXPANDED RUBBER PIPE CONNECTORS SERIES 3000

**GOODYEAR**  
RUBBER PRODUCTS, INC.

☎ 727-342-5088

You can also email us at  
[GRP@goodyearrubberproducts.com](mailto:GRP@goodyearrubberproducts.com)

# Proco Series 300 Flagged Rubber Pipe Connectors

**PROCO Series 300** Rubber Pipe is designed for tough demanding industrial and commercial applications as found in: Chemical-Petrochemical and Industrial Process Piping Systems, Power Generating Plants, Steel Mills, Marine Services, Pulp/Paper Systems, Water-Waste/Water-Sewage and Pollution Control Systems. Specific equipment applications could include: Pumps, Cooling Towers, Compressors, Blowers, Fans, Absorption Machines, etc. Installed next to mechanical equipment or between the anchor points of a piping system, specify the PROCO Series 300 to: (1) Isolate Mechanical Vibration, (2) Reduce System Noise, (3) Absorb Pipe Movement/Stress, (4) Compensate Alignment/Offset, (5) Eliminate Electrolysis, (6) Protect Against Start-Up/Surge Forces. When you need an engineered rubber solution to a piping system problem, call PROCO.

**Engineered For Your Application.** Each PROCO Series 300 Rubber Pipe is constructed with a smooth interior tube specially compounded from an elastomer that satisfies the Chemical-Abrasion-Sound requirements of your application (See Table 2). Multiple plies of tough fabric and helical spring steel wire are embedded into the pipe wall during the manufacturing process to provide a product designed for your pressure and vacuum requirements. Available styles include:

**Style 310-R:** Precision molded to specific lengths as listed in Table 3. The built-in rubber flanges are drilled to ANSI - 125/150#.

**Style 310:** Manufactured by conventional methods which allow for fabrication to a specific length requirement, in addition to lengths as shown in Table 3. Standard with 125/150# drilling, the Style 310 can also be fabricated to meet other drilling patterns.

**Style 320:** Designed for high pressure applications (See Table 4); this connector manufactured similar to Style 310. Flanges are usually drilled to ANSI 250/300# with other drilling patterns furnished on request.

**Absorbs Pipe-Wall and Fluid-Borne Noise.** The PROCO quiet-operating Series 300 is a replacement for "sound transmitting" metallic connectors. Compare the Acoustical Impedance ratings of rubber and other materials, as shown in Table 1. Pipe-Wall sound is absorbed as the noise carried by the piping both enters and leaves the rubber section.

Connector length further influences absorption as sound loses energy traveling axially through the rubber. For optimum lengths, see Table 3. Fluid-borne noise is absorbed by the volumetric expansion (breathing) of the connector. This action cushions water hammer, and smoothes out pumping impulses.

**Isolate Vibrations and Motion.** Vibration originating from mechanical equipment is absorbed by the PROCO Series 300. Rubber pipe connectors should be installed right after and ahead of the equipment generating the vibration, thus isolating the equipment. As most machinery vibrates in a radial direction from the main shaft, for optimum performance the pipe connector should be installed horizontally and parallel to this shaft. While PROCO Series 300 Rubber Pipe will accept some axial motion, it is principally designed to accept transverse motion. When installed at right angles to the direction of the pipe motion (movement), PROCO rubber pipe connectors can absorb large amounts of expansion.

For major two-plane vibration/motion it is best to use two flexible rubber pipe connectors installed at right angles, one to absorb the horizontal vibration and one to absorb the vertical vibration. A tension anchor is usually advisable to stabilize the elbow between the connectors. Note: For maximum vibration transmission reduction, the piping section beyond the rubber connector must be anchored or sufficiently rigid.

**Prevents Electrolysis and Electrolytic Action.** In chemical applications when metallic connectors are used, they are generally of a metal dissimilar from the pipe-line. This could create an electrolytic galvanic action that could be destructive to the connector, equipment or piping system. The use of the PROCO Series 300 eliminates this potential hazard. Additionally, because the all-rubber connector eliminates metal-to-metal contact at the flange face, electrolysis is stopped.

**Systems Misalignment Compensation.** In a rigid piping system, the installation of the PROCO Series 300 Rubber Pipe adds a flexible component that is automatically selfcorrecting for misalignment created by structural movements caused by settling, expansion or ground shifts (See Table 3).

**Chemical Or Abrasive Service Capability At Minimal Cost:** Expensive, exotic metal connectors for chemical service can be replaced with the PROCO Series 300. Fabricated with low cost chemical resistant elastomer such as: Chlorobutyl, EPDM, Gum, CSM, Neoprene and Nitrile; insures a rubber connector compatible with the fluid being pumped or piped (See Table 1). Our Gum or Neoprene products should be specified when handling abrasive slurries. Use PROCO "Chemical to Elastomer Guide" to specify an elastomer for your requirements.



**Protecting Piping & Equipment  
Systems From Stress/Motion**

**GOODYEAR**  
RUBBER PRODUCTS, INC.

☎ 727-342-5088

You can also email us at  
[GRP@goodyearrubberproducts.com](mailto:GRP@goodyearrubberproducts.com)

# Series 300 Performance Data

**Table 1: Comparison of Material Acoustical Impedances**

Material	Sound Velocity In. / Sec.	Density Lbs./In. <sup>3</sup>	Acoustical Impedance Lbs. / In. <sup>2</sup> Sec.	Relative Impedance
Steel	206,500	.283	58,440	551.3
Copper	140,400	.320	44,930	423.9
Cast Iron	148,800	.260	38,690	365.0
Lead	49,800	.411	20,470	193.1
Glass	216,000	.094	20,300	191.5
Concrete	198,000	.072	14,260	134.5
Water	56,400	.036	2,030	19.2
Pine	132,000	.0145	1,910	18.0
Cork	19,200	.0086	165	1.6
Rubber	2,400	.0442	106	1.0

NOTES: Acoustical impedance is defined as the product of material density times velocity of sound in that material. In acoustical systems low impedance corresponds to low sound transmission.  
Relative impedance is based on Rubber = 1.0

**Table 2: Available Styles and Materials**

For Specific Elastomer Recommendations, See: **PROCO™ "Chemical To Elastomer Guide"**

310	310-R	320	PROCO Material Code	Cover Elastomer	Tube Elastomer	Maximum Operating Temp °F	F.S.A. Material Class
*	*	*	BB	Chlorobutyl	Chlorobutyl	250°	Special II
*	*	*	BT	Chlorobutyl	Teflon®	250°	Special II
*	*	*	EE	EPDM	EPDM	250°	Special II
*	*	*	NR	Neoprene	Natural	180°	Std. I
*	*	*	NH	Neoprene	CSM	212°	Std. II
*	*	*	NN	Neoprene	Neoprene	225°	Std. II
*	*	*	NP	Neoprene	Nitrile	212°	Std. II

Product "cover" can be CSM coated on special order.  
Style 310/NN meets ASTM, Class A, Type III and conforms to all USCG requirements.

NOTES: 1. Teflon is a registered trademark of the DuPont Company.  
2. Products with Teflon® "tubes" are not recommended with vacuum service.

**Reduce System Stress And Strain.** Rigid attachment of piping to critical or mechanical equipment can produce excessive loading. Thermal or mechanically created strain-stress-shock are cushioned and absorbed with the installation of a flexible PROCO Series 300 Rubber Pipe.

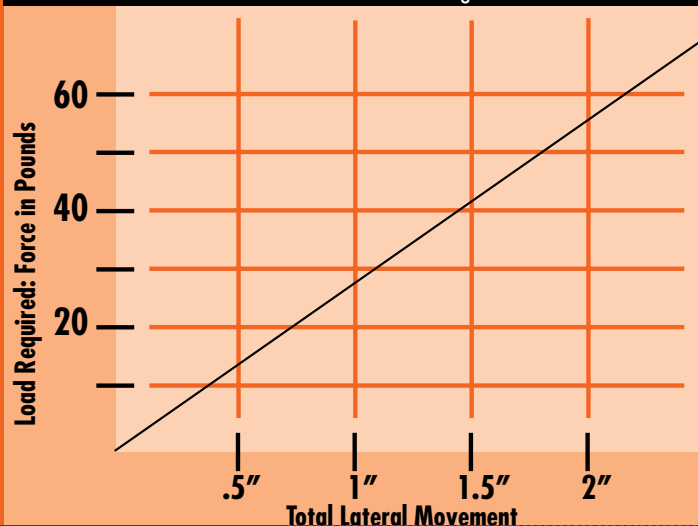
**Full Flow With Less Turbulence Or Material Entrapment.** The smooth bore of the PROCO Series 300 Rubber Pipe Connector allows full flow without turbulence. Metallic connectors depend upon bellows or convolutions to absorb motion. These bellows/ convolutions could create flow turbulence and also create an area for material entrapment or bacteria growth.

**Leak Free Without Gaskets Or Packing.** The full-face rubber flange of the PROCO Series 300 Rubber Pipe Connector is self gasketing. Additionally, the Style 310-R features a molded in place "O-Ring" on each flange-face for faster sealing with less torque at installation and less long-term maintenance. Unlike interlocked metallic connectors, the Series 300 features a one-piece seamless tube that does not require packing. Our rubber connector is suitable for all air, gas, and fluids, including "searching" thin fluids.

**Control Rod Assembly Usage.** PROCO Style 491 Control Units are designed to protect the Series 300 Pipe Connector from excessive elongation. Control rods must be used: (1) when the piping containing the rubber pipe connector is not anchored and, (2) when the rubber pipe connector is attached to resiliently supported pipe or equipment.

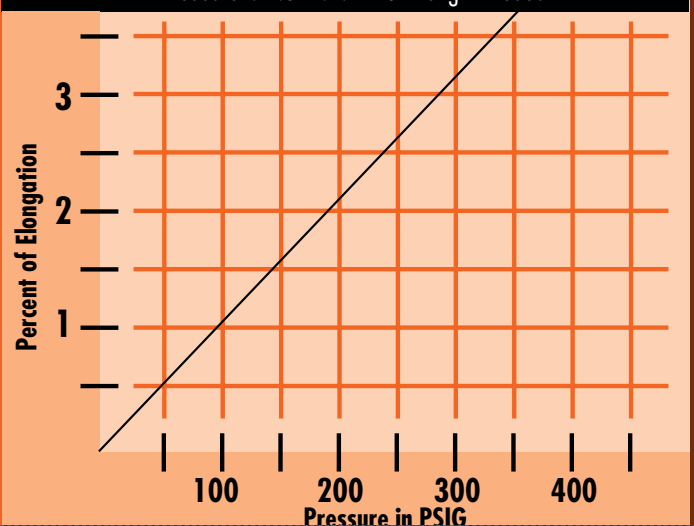
## Force Required for Lateral Displacement

Based on: 2.5" I.D. x 18" Length Product



## Pressure-Elongation Curve

Based on: 2.5" I.D. x 18" Length Product



# Series 300 Performance Data continued

**Table 3: Sizes • Movements • Flange Dimensions • Weights • Pressures**

Nominal Pipe Size: Pipe I.D.	Neutral Length	Movement Capability From Neutral				125/150# Flange Dimensions				Rubber Pipe Dimensions		Approx. Weight (lbs)		Operating Pressures <sup>3</sup>		
		In. of Axial Compression	In. of Axial Extension	± In. of Lateral Deflection	± In. of Angular Deflection	Flange O.D.	Bolt Circle	# of Holes	Size of Holes	"A" Flange Thickness	"B" Body Thickness	Style 310-R	Retaining Rings (set)	Style 310-R	Style 310	Style 320
<b>.75</b>	12*	.158	.158	1.97	21.8°	3.875	2.750	4	0.625	0.591	0.472	2.4	1.5	300	300	
	18	.236	.236	2.96	31.0°							3.2	1.5			
<b>1</b>	12*	.158	.158	1.77	17.7°	4.250	3.120	4	0.625	0.591	0.551	3.3	1.9	300	300	
	18	.236	.236	2.66	25.6°							4.2	1.9			
<b>1.25</b>	12*	.158	.158	1.58	14.0°	4.625	3.500	4	0.625	0.591	0.551	4.0	2.4	300	300	
	18	.236	.236	2.36	20.6°							5.0	2.4			
	24	.315	.315	3.15	26.6°							6.0	2.4			
<b>1.5</b>	12*	.158	.158	1.39	11.3°	5.000	3.880	4	0.625	0.591	0.551	4.3	2.6	300	300	
	18	.236	.236	2.09	16.7°							5.4	2.6			
	24	.315	.315	2.78	21.8°							6.5	2.6			
<b>2</b>	12*	.158	.158	1.18	9.1°	6.000	4.750	4	0.750	0.591	0.551	5.6	2.6	250	250	
	18	.236	.236	1.77	13.5°							6.8	2.6			
	24	.315	.315	2.36	17.7°							8.0	2.6			
	30	.354	.354	2.96	19.8°							9.2	2.6			
<b>2.5</b>	12*	.158	.158	.98	7.0°	7.000	5.500	4	0.750	0.591	0.551	6.9	5.3	200	200	
	18	.236	.236	1.48	10.5°							8.2	5.3			
	24	.315	.315	1.97	13.8°							9.5	5.3			
	30	.354	.354	2.46	15.5°							10.0	5.3			
<b>3</b>	12*	.158	.158	.79	5.7°	7.500	6.000	4	0.750	0.591	0.551	8.6	5.6	150	150	
	18	.236	.236	1.18	8.5°							10.6	5.6			
	24	.315	.315	1.58	11.3°							11.7	5.6			
	30	.354	.354	1.97	12.7°							14.6	5.6			
	36	.433	.433	2.36	15.4°							16.6	5.6			
<b>3.5</b>	12	.158	.158	.59	5.1°	8.500	7.000	8	0.750	0.591	0.669	9.7	6.5	150	150	
	18*	.236	.236	.89	7.6°							12.2	6.5			
	24	.315	.315	1.18	10.1°							14.7	6.5			
	30	.354	.354	1.48	11.3°							17.2	6.5			
	36	.433	.433	1.77	13.7°							19.7	6.5			
<b>4</b>	12	.158	.158	.59	4.6°	9.000	7.500	8	0.750	0.591	0.669	10.9	7.3	175	175	
	18*	.236	.236	.89	6.8°							14.5	7.3			
	24	.315	.315	1.18	9.1°							17.4	7.3			
	30	.354	.354	1.48	10.2°							19.7	7.3			
	36	.433	.433	1.77	12.4°							21.9	7.3			
	48	.472	.472	1.98	14.8°							27.2	7.3			
<b>5</b>	12	.158	.158	.45	3.7°	10.000	8.500	8	0.875	0.591	0.669	13.5	7.9	175	175	
	18*	.236	.236	.67	5.5°							16.6	7.9			
	24	.315	.315	.89	7.3°							20.1	7.9			
	30	.354	.354	1.12	8.2°							23.1	7.9			
	36	.433	.433	1.34	10.0°							26.1	7.9			
<b>6</b>	12	.158	.158	.45	3.1°	11.000	9.500	8	0.875	0.591	0.709	18.9	9.1	150	150	
	18	.236	.236	.67	4.6°							19.9	9.1			
	24*	.315	.315	.89	6.1°							24.1	9.1			
	30	.354	.354	1.12	6.8°							27.2	9.1			
	36	.433	.433	1.34	8.3°							31.5	9.1			
	48	.472	.472	1.55	9.9°							39.0	9.1			

**Table 3: Sizes • Movements • Flange Dimensions • Weights • Pressures**

Nominal Pipe Size: Pipe I.D.	Neutral Length	Movement Capability From Neutral				125/150# Flange Dimensions				Rubber Pipe Dimensions		Approx. Weight (lbs)		Operating Pressures <sup>3</sup>		
		In. of Axial Compression	In. of Axial Extension	± In. of Lateral Deflection	± In. of Angular Deflection	Flange O.D.	Bolt Circle	# of Holes	Size of Holes	"A" Flange Thickness	"B" Body Thickness	Style 310-R	Retaining Rings (set)	Style 310-R	Style 310	Style 320
8	12	.118	.118	.35	1.7°	13.500	11.750	8	0.875	0.591	0.787	23.4	14.0			
	18	.158	.158	.53	2.3°							29.4	14.0			
	24*	.236	.236	.71	3.4°							35.7	14.0			
	30	.276	.276	.89	4.0°							40.2	14.0			
	36	.354	.354	1.06	5.1°							47.4	14.0			
	48	.472	.472	1.42	6.8°							59.4	14.0			
10	12	.118	.118	.32	1.4°	16.000	14.250	12	1.000	0.787	0.866	26.0	17.0	150	150	250
	18	.158	.158	.47	1.8°							37.0	17.0			
	24*	.236	.236	.63	2.7°							48.7	17.0			
	30	.276	.276	.79	3.2°							59.0	17.0			
	36	.354	.354	.95	4.1°							70.0	17.0			
	48	.472	.472	1.26	5.5°							92.0	17.0			
12	12	.118	.118	.24	1.1°	19.000	17.000	12	1.000	0.787	0.984	36.0	24.1			
	18	.158	.158	.36	1.5°							51.0	24.1			
	24*	.236	.236	.47	2.3°							66.5	24.1			
	30	.276	.276	.59	2.7°							81.0	24.1			
	36	.354	.354	.71	3.4°							96.0	24.1			
	48	.472	.472	.95	4.2°							126.0	24.1			
14	12	.118	.118	.24	1.0°	21.000	18.750	12	1.125	0.787	0.984	58.0	26.8	125*	125	200
	18	.158	.158	.36	1.3°							83.0	26.8			
	24*	.236	.236	.47	2.0°							108.0	26.8			
	30	.276	.276	.59	2.3°							133.0	26.8			
	36	.354	.354	.71	2.9°							157.0	26.8			
	48	.472	.472	.95	3.9°							208.0	26.8			
16	12	.118	.118	.24	0.7°	23.500	21.250	16	1.125	0.787	0.984	83.0	32.1			
	18	.158	.158	.36	1.3°							118.0	32.1			
	24*	.236	.236	.47	1.7°							153.0	32.1			
	36	.354	.354	.71	2.6°							233.0	32.1			
	48	.472	.472	.95	3.4°							294.0	32.1			
	18	12	.112	.112	.18							0.9°	25.000			
18		.118	.118	.24	1.2°	157.5	34.6									
24*		.236	.236	.24	1.5°	205.0	34.6									
36		.354	.354	.36	2.3°	300.0	34.6									
48		.472	.472	.48	3.1°	394.0	34.6									
20		24*	.236	.236	.24	1.4°	27.500	25.000	20	1.250	1.000	1.000		270.0	35.9	
	36	.354	.354	.36	2.1°	394.0							35.9			
	48	.472	.472	.48	2.7°	519.0							35.9			

NOTES:\*1. For optimum noise and vibration absorption, use this or longer length  
 2. The degree of angular movement is based on the maximum rated extension.  
 3. Pressure rating is based on 170°F. operating temperature. Vacuum rating is 26" Hg in all cases except where \* appears.  
**Larger I.D. or length sizes are available upon special request. Contact PROCO**

# Series 300 Drilling Chart

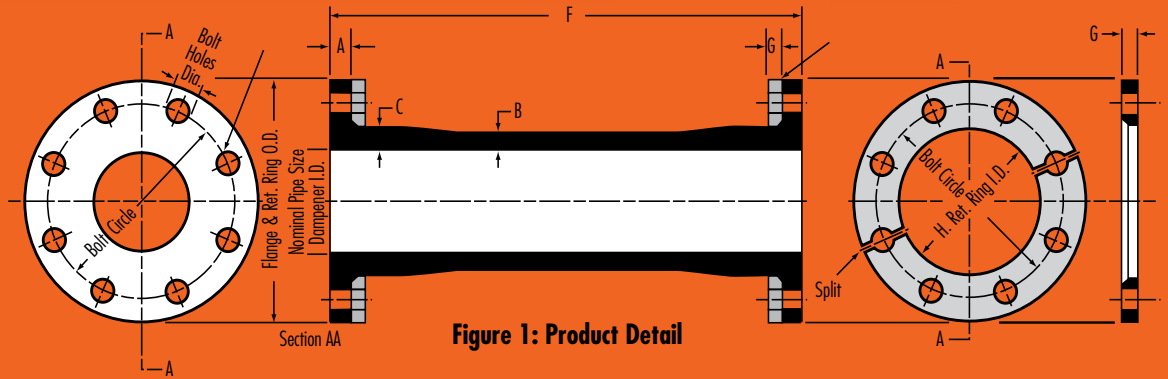


Figure 1: Product Detail

Table 4: Standard Drilling • Connector Dimensions • Pressures • Weights

Nominal Pipe Size: Pipe I.D.	125/150# Flange Dimensions <sup>1</sup> Pipe • Rings • Rods				250/300# Flange Dimensions <sup>2</sup> Pipe • Rings • Rods				Pipe Dimensions See Figure 1		Operating Pressures <sup>3</sup> Positive In P.S.I.G			Retaining Ring Weight Per Set	
	Flange O.D.	Bolt circle	# of Holes	Size of Holes	Flange O.D.	Bolt circle	# of Holes	Size of Holes	"A" Flange Thickness	"B" Body Thickness	Style 310R	Style 310	Style 320	Style #481 150 Pounds	Style #484 300 Pounds
.75	3.88	2.75	4	.625	4.62	3.25	4	.750	.591	.472	300	150	300	1.5	2.0
1	4.25	3.12	4	.625	4.88	3.50	4	.750	.591	.551	300	150	300	1.9	2.9
1.25	4.62	3.50	4	.625	5.25	3.88	4	.750	.591	.551	300	150	300	2.4	3.0
1.5	5.00	3.88	4	.625	6.12	4.50	4	.875	.591	.551	300	150	300	2.6	4.4
2	6.00	4.75	4	.750	6.50	5.00	8	.750	.591	.551	250	150	250	3.6	4.3
2.5	7.00	5.50	4	.750	7.50	5.88	8	.875	.591	.591	200	150	250	5.3	5.5
3	7.50	6.00	4	.750	8.25	6.63	8	.875	.591	.591	175	150	250	5.6	6.0
3.5	8.50	7.00	8	.750	9.00	7.25	8	.875	.591	.669	175	150	250	6.5	7.0
4	9.00	7.50	8	.750	10.00	7.88	8	.875	.591	.669	175	150	250	7.3	10.0
5	10.00	8.50	8	.875	11.00	9.25	8	.875	.591	.669	175	150	250	7.9	11.6
6	11.00	9.50	8	.875	12.50	10.63	12	.875	.591	.709	150	150	250	9.1	14.5
8	13.50	11.75	8	.875	15.00	13.00	12	1.000	.591	.787	150	150	250	14.0	19.6
10	16.00	14.25	12	1.000	17.50	15.25	16	1.125	.787	.866	150	150	250	17.0	23.0
12	19.00	17.00	12	1.000	20.50	17.75	16	1.250	.787	.984	150	150	250	24.1	31.3
14	21.00	18.75	12	1.125	23.00	20.25	20	1.250	.787	.984	125*	125	200	26.8	37.0
16	23.50	21.25	16	1.125	25.50	22.50	20	1.375	.787	.984	100*	100	150	32.1	45.0
18	25.00	22.75	16	1.250	28.00	24.75	24	1.375	.875	1.000	100*	100	150	30.6	58.0
20	27.50	25.00	20	1.250	30.50	27.00	24	1.375	1.000	1.000	100*	100	150	35.9	67.0

NOTES: 1. Dimensions shown meet 125/150# standards of: ANSI B-16.1, B-16.24, B-16.5; AWWA C-207 Table 1 and 2, Class D; MSS SP-44 and NBS/PS 15-69.  
 2. Dimensions shown meet 250/300# standards of: ANSI B-16.1, B-16.24, B-16.5 and MSS SP-44 Class 300.  
 3. Vacuum rating is 26" hg. In all cases except where \* appears. Pressure rating is based on 170°F. operating temperature.

# Rubber Expansion Joint Specification Form

Company Name:

Mailing Address:

City:

State:

Zip/Postal Code:

Contact Person:

E-Mail Address:

Telephone:

## SIZE

### Pipe Size of Application (Inches)

Nominal pipe size (I.D.)

### Installed Length (Inches)

Dimension between mating flanges.

Also known as: Flange-to-flange, OAL or Takeout.

## FLOWING MEDIUM

### Flowing Medium

Indicate fluid being piped. Refer to our "Chemical/Rubber Guide" for elastomer compatibility.

### Type of Medium

Indicate if liquid, gas, slurry, solids, etc.

### Temperature of Flowing Medium (F)

Indicate both operating and maximum temperatures at the expansion joint

Op.

Max.

Note: See Table: "Comparative Properties of Typical Proco Products, Inc. Elastomers"

## PRESSURES

### Operating Pressure of the System

Actual pressure in which system works in normal conditions (use PSIG and Hg)

+  -

### Design Pressure of the System

Highest/most severe pressure expected during operation (use PSIG and Hg)

+  -

### Surge Pressure of the System

Increased pressure due to pump starts, valve closings, etc. (use PSIG and Hg)

+  -

### Test Pressure of the System

Hydrostatic test used to demonstrate system capability (use PSIG and Hg)

+  -

### Type of Pressure

Constant, intermittent, shock, pulsating, etc.

## MOVEMENTS

### Axial Compression

In inches as a result of pipe extension-expansion

### Actual Extension

In inches as a result of pipe contraction

### Lateral Deflection at Joint

In inches

### Angular Movement at Joint

In degrees

### Torsional Movement at Joint

In degrees

## MISCELLANEOUS

### Pipe Flange Drilling

Indicate specific standard such as: ANSI, DIN, JIS, B5, Navy.   
If special, provide: Flange O.D., Bolt Circle, Number & Size of Holes

### Mating Pipe Flange Thickness

In inches

### Location of Joint Installation

Indoors or outdoors

### Retaining Rings

Are required on all installations. Reusable, they need not be ordered with replacement or spare expansion points  Yes  No

### Control Unit Assemblies

Are recommended for use in all expansion joint applications.  Yes  No  
Control units must be used when piping support or anchoring is insufficient

### Hydrostatic Test of Joint Required by Manufacturer of Product

Yes  No

### Quantity Required



2431 North Wigwam Dr. (95205)  
 P.O. Box 590 • Stockton, CA  
 95201-0590 • USA

Toll-Free Phone: (800) 344-3246 **NATIONWIDE AND CANADA**

Facsimile: (209) 943-0242

(209) 943-6088 **INTERNATIONAL**

email: [sales@procoproducts.com](mailto:sales@procoproducts.com)



Industrial Distributor Co-op



**REPRESENTED BY:**



**GOODYEAR**  
 RUBBER PRODUCTS, INC.

**727-342-5088**

You can also email us at  
**GRP@goodyearrubberproducts.com**



# Series 440



**GOODYEAR**  
RUBBER PRODUCTS, INC.

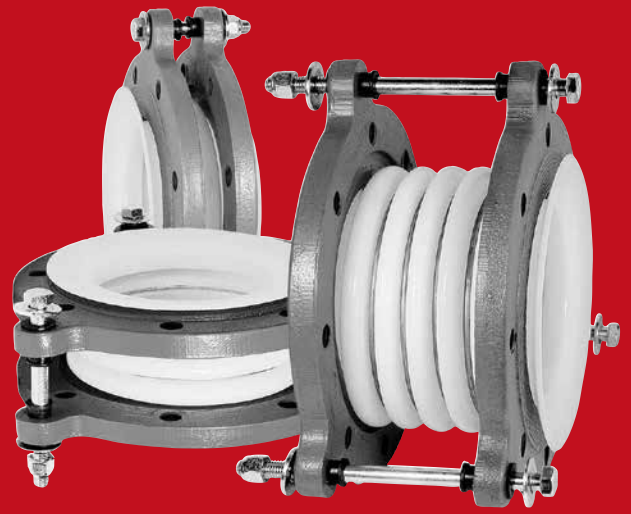
☎ 727-342-5088

You can also email us at  
[GRP@goodyearrubberproducts.com](mailto:GRP@goodyearrubberproducts.com)

# PROCO<sup>TM</sup>

## SERIES

# 440



## molded PTFE expansion joints

The PROCO Series 440 PTFE Molded Expansion Joints are used for corrosive applications found in: Chemical-Petrochemical, Industrial Process Piping Systems, Power Generation Plants, Pulp/Paper Plants, Water-Wastewater Sewage and Pollution Control Systems where metallic joints/lap joints or PTFE & FEP-lined rubber expansion joints may have been previously used or specified. Specify PROCO Series 440 expansion joints for installation between anchor points or next to mechanical equipment such as: Absorption Machines, Blowers, Chillers, Fans, Graphite Heat Exchangers, Glass Lined Vessels, Pumps, and Exotic Alloy/Plastic/Glass Lined Piping Systems. The Series 440 expansion joints are designed to: (1) Absorb Pipe Movements/Stress, (2) Reduce System Noise, (3) Reduce Mechanical Vibration, (4) Compensate Alignment/Offset, (5) Eliminate Electrolysis, (6) Protect against Start-up/Surge Forces. Our history in the manufacture of expansion joint products dates back to 1930. When an engineered solution is needed to solve a piping problem, call PROCO.

**Engineered For Your Application.** The PROCO Series 440 PTFE expansion joints are available in 2, 3, and 5 convolutions. Each convolution profile offers different overall lengths (face-to-face dimensions), movements and pressure/temperature rating to fit the required specification. Available styles include:

- **Style 442-BD:** Features two convolutions for minimal movements, higher pressure/temperature ratings and short face-to-face opening requirements. Style 442-BD sizes range from 1" to 24" diameter. (See Table 1)
- **Style 443-BD:** Features three convolutions and is designed for moderate movement and ease of system installation. Style 443-BD sizes range from 1" to 24" diameter. (See Table 2)
- **Style 445-BD:** Features five convolutions, and is designed for maximum movements, low pressure/temperature ranges, vibration reduction and greater face-to-face lengths. Style 445-BD sizes range from 1" to 20" diameter. (See Table 3)
- **Style 440-BE:** Features varying Neutral Lengths with Styles' 440-BD Limit Bolts. (See Table 4)

**Absorbs Pipe-Wall and Fluid-Borne Noise.** The quiet operating PROCO Series 440 PTFE expansion joints are a replacement for "sound transmitting" metallic/lap joints. Pipe Wall sound loses energy and is absorbed as the noise carried by the piping enters and exits the PTFE section. Fluid-borne noise is absorbed by the volumetric expansion (breathing of the connector). This action cushions water hammer and smoothes out pumping impulses.

**Isolates Vibration and Motion.** PROCO Series 440 PTFE expansion joints should be installed immediately after and ahead of equipment generating vibration in order to isolate the rotating/vibrating equipment from the rest of the piping system. For optimum performance, the PROCO Series 440 PTFE expansion joints should be installed horizontally to the shaft. Vertical and perpendicular installations are also acceptable as these expansion joints will accept axial, lateral and angular movements as well as vibration. Note: For maximum vibration transmission reduction, the pipe section beyond the PTFE expansion joints must be anchored or sufficiently rigid.

**Reduces System Stress and Strain.** Rigid attachment of piping to critical or mechanical equipment can produce excessive loading. Thermal or mechanically created strain-stress-shock are cushioned and absorbed with the installation of a flexible, low spring rate, PROCO Series 440 PTFE expansion joint. The PROCO Series 440 PTFE expansion joint adds a flexible component to the system that automatically self-corrects for misalignment created by structural movements caused by settling, pipe expansion or ground shifts.

**Tested Force Pound and Spring Rate Tables.** At PROCO we have machine tested nearly every size of the Series 440 PTFE expansion joints for Axial and Lateral Spring Rates and have provided Thrust/Force factors so designers can properly design system restraints. It should be noted that the PROCO Series 440 PTFE expansion joints are in accordance with the performance characteristics of the Fluid Sealing Association's Non-Metallic Expansion Joint Division.

**Superior "Flex Life" and Strength.** The PROCO Series 440 PTFE expansion joints are contour molded from extruded tubing providing superior "Flex Life" and Strength. Utilizing TEFLON® T-62 resins from DuPont, the PROCO Series 440 PTFE expansion joints provide dramatically more cycle life than that of PFA or FEP.

**Flange and Limit Bolts.** All PROCO Series 440 PTFE expansion joint flange configurations are coated with a rust inhibitive primer to prevent corrosion and are dimensionally tapped to ANSI 125/150# Standards. Hole drilling on center line, other drilling standards, or other flange materials, such as 316 stainless, 304 stainless, or Epoxy Coated flanges are available on special order. In addition, all PROCO Series 440 PTFE expansion joints are supplied with factory set limit bolts to prevent over-extension during operation.

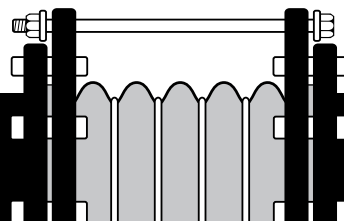
**Chemical Service Capability at Minimal Cost.** Expensive, exotic metal, PTFE or FEP lined rubber expansion joints for severe chemical service can be replaced with the low cost PROCO Series 440 PTFE expansion joints. The PTFE bellows are van stoned to the flanges which allows all wetted surfaces to come in contact with only the PTFE material. Specify the PROCO Series 440 PTFE expansion joints where high temperatures coupled with lower pressures or lower temperatures coupled with higher pressures are proposed. The PROCO Series 440 PTFE offers the lowest cost expansion joint that is impervious to chemical attack. Use the PROCO "Chemical to Elastomer Guide" for reference on chemical compatibility.

**Services and Locations.** PROCO Series 440 PTFE Expansion Joints have been supplied and successfully used by a range of customers worldwide in the process industries for use in both organic and inorganic chemical processing and production, including such demanding applications as agrochemical and pharmaceutical chemical production, acid processing and food manufacture.

**Information • Ordering • Pricing • Delivery.** Day or night, weekends and holidays... the PROCO phones are monitored 24 hours around the clock. When you have a question, you can call us.

Toll-Free Phone	800 / 344-3246 USA/CANADA
International Calls	209 / 943-6088
Fax	209 / 943-0242
Email	sales@procoproducts.com
Website	www.procoproducts.com

Weekday office hours are 5:30 a.m. to 5:15 p.m. Pacific Time.



**Protecting Piping And Equipment  
Systems From Stress/Motion**

**GOODYEAR**  
RUBBER PRODUCTS, INC.

☎ 727-342-5088

You can also email us at  
[GRP@goodyearrubberproducts.com](mailto:GRP@goodyearrubberproducts.com)

# PROCO™

STYLE

# 440-BE



molded PTFE expansion joints

Table 4: Sizes • Movements • Spring Rates • Flange Standards • Temperatures • Vacuum • Weights

NOMINAL SIZE I.D.	NEUTRAL LENGTH INCHES	MOVEMENT CAPABILITIES <sup>1</sup>			SPRING RATE CAPABILITY <sup>2</sup>			EXPANSION JOINT FLANGE DRILLING							PRESSURE AT TEMPERATURE (PSIG) @ °F								VACUUM RATING <sup>3</sup>	WEIGHT / LBS			
		± AXIAL (Δx) MOVEMENT	LATERAL (Δy) DEFLECTION	ANGULAR DEFLECTION	COMPRESSION SPRING RATE	EXTENSION SPRING RATE	LATERAL SPRING RATE	THRUST FACTOR	# HOLES	THREADED HOLE SIZE	BOLT CIRCLE FLANGE "A"	PTFE FLARE O.D. "B"	FLANGE THICKNESS	NOMINAL FLANGE O.D.	LIMIT BOLT DIAMETER	BOLT CIRCLE LIMIT BOLT "C"	LIMIT BOLT "EAR" O.D.	70°	100°	150°	200°	250°			300°	350°	400°
		IN	IN	DEG.	LB <sub>f</sub> /IN	LB <sub>f</sub> /IN	LB <sub>f</sub> /IN																				
<b>Style 442-BE</b>																											
1.00	1.750	0.344	.125	7	140	144	120	2.76	4	1/2-13	3.125	2.000	.438	4.250	.250	5.125	6.000	185	170	148	130	115	100	84	68	29.9° @ 425°F	2
1.50	1.813	0.344	.125	7	240	200	240	4.60	4	1/2-13	3.875	2.875	.469	5.000	.250	5.875	6.750	185	170	148	130	115	100	84	68	29.9° @ 425°F	2
2.00	1.875	0.344	.125	7	430	350	440	7.07	4	5/8-11	4.750	3.625	.484	6.000	.375	6.875	8.125	185	170	148	130	115	100	84	68	29.9° @ 425°F	7
3.00	2.188	0.406	.188	7	650	320	350	15.90	4	5/8-11	6.000	5.000	.578	7.500	.375	8.750	10.000	185	170	148	130	115	100	84	68	29.9° @ 425°F	10
4.00	2.281	0.438	.250	7	360	280	630	23.75	8	5/8-11	7.500	6.188	.578	9.000	.375	9.875	11.125	185	170	148	130	115	100	84	68	29.9° @ 400°F	18
6.00	2.531	0.469	.250	7	460	350	720	50.24	8	3/4-10	9.500	8.500	.641	11.000	.500	12.500	14.000	185	170	148	130	115	100	84	68	29.9° @ 400°F	29
8.00	2.750	0.531	.250	7	300	230	800	81.48	8	3/4-10	11.750	10.625	.688	13.500	.500	14.750	16.250	164	150	129	112	100	87	73	60	29.9° @ 250°F	47
10.00	2.969	0.563	.250	6	1280	870	1000	108.38	12	7/8-9	14.250	12.750	0.734	16.000	.500	17.500	19.000	164	150	129	112	100	87	73	60	29.9° @ 250°F	64
12.00	3.094	0.594	.250	5	380	240	1000	176.63	12	7/8-9	17.000	15.000	0.813	19.000	.625	20.500	22.000	70	59	48	40	35	30	26	22	29.9° @ 75°F	115
<b>Style 443-BE</b>																											
1.00	2.313	0.500	.250	14	130	130	260	2.81	4	1/2-13	3.125	2.000	.438	4.250	.250	5.125	6.000	138	126	107	90	76	64	53	45	29.9° @ 400°F	2
1.50	2.406	0.531	.250	12	80	70	110	5.09	4	1/2-13	3.875	2.875	.469	5.000	.250	5.875	6.750	138	126	107	90	76	64	53	45	29.9° @ 400°F	4
2.00	2.500	0.531	.375	12	70	80	160	9.11	4	5/8-11	4.750	3.625	.484	6.000	.375	6.875	8.125	138	126	107	90	76	64	53	45	29.9° @ 400°F	8
3.00	2.906	0.625	.500	10	140	160	190	16.91	4	5/8-11	6.000	5.000	.578	7.500	.375	8.750	10.000	138	126	107	90	76	64	53	45	29.9° @ 400°F	13
4.00	3.063	0.656	.500	10	220	160	190	25.40	8	5/8-11	7.500	6.188	.578	9.000	.375	9.875	11.125	138	126	107	90	76	64	53	45	29.9° @ 400°F	19
6.00	3.375	0.719	.563	9	350	190	540	50.24	8	3/4-10	9.500	8.500	.641	11.000	.500	12.500	14.000	138	126	107	90	76	64	53	45	29.9° @ 300°F	30
8.00	3.656	0.781	.563	9	450	170	750	81.48	8	3/4-10	11.750	10.625	.688	13.500	.500	14.750	16.250	120	110	94	80	67	57	47	38	29.9° @ 125°F	48
<b>Style 445-BE</b>																											
1.00	3.500	0.844	.500	20	50	110	50	2.81	4	1/2-13	3.125	2.000	.438	4.250	.250	5.125	6.000	72	61	46	40	34	29	27	24	NOT DESIGNED FOR VACUUM SERVICE	2
1.50	3.625	0.785	.500	20	75	80	50	5.09	4	1/2-13	3.875	2.875	.469	5.000	.250	5.875	6.750	72	61	46	40	34	29	27	24	NOT DESIGNED FOR VACUUM SERVICE	5
2.00	3.750	0.875	.500	15	60	50	50	9.11	4	5/8-11	4.750	3.625	.484	6.000	.375	6.875	8.125	72	61	46	40	34	29	27	24	NOT DESIGNED FOR VACUUM SERVICE	9
3.00	4.375	1.031	.500	17	55	60	170	16.91	4	5/8-11	6.000	5.000	.578	7.500	.375	8.750	10.000	72	61	46	40	34	29	27	24	NOT DESIGNED FOR VACUUM SERVICE	14
4.00	4.563	1.094	.625	15	70	60	80	25.40	8	5/8-11	7.500	6.188	.578	9.000	.375	9.875	11.125	72	61	46	40	34	29	27	24	NOT DESIGNED FOR VACUUM SERVICE	20
6.00	5.031	1.188	.625	15	190	130	195	50.24	8	3/4-10	9.500	8.500	.641	11.000	.500	12.500	14.000	72	61	46	40	34	29	27	24	NOT DESIGNED FOR VACUUM SERVICE	31

NOTES: 1. Movements are non-concurrent and based from Neutral Length with Limit Bolts installed.  
 2. Spring Rate Capability is based on 1" of movement at zero pressure conditions.  
 3. Vacuum Rating is based from fully extended position. Style 445-BE is not designed for Vacuum Service.

PROCO STYLE NUMBER: \_\_\_\_\_ STYLE 440-BE MATERIALS OF CONSTRUCTION \_\_\_\_\_



727-342-5088

You can also email us at GRP@goodyearrubberproducts.com

# PROCO™

## STYLE

# 442-BD

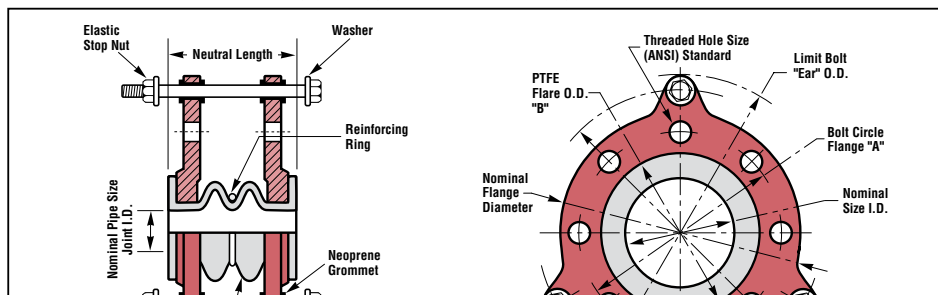


### molded PTFE expansion joints

**Table 1: Sizes • Movements • Spring Rates • Flange Standards • Temperatures • Vacuum • Weights**

NOMINAL SIZE I.D.	NEUTRAL LENGTH INCHES	MOVEMENT CAPABILITIES BASED ON TWO CONVOLUTION DESIGN <sup>1</sup>			SPRING RATE CAPABILITY <sup>2</sup>				EXPANSION JOINT FLANGE DRILLING								PRESSURE AT TEMPERATURE (PSIG) @ °F								VACUUM RATING <sup>3</sup>	WEIGHT / LBS		
		± AXIAL (Δx) MOVEMENT	LATERAL (Δy) DEFLECTION	ANGULAR DEFLECTION	COMPRESSION SPRING RATE	EXTENSION SPRING RATE	LATERAL SPRING RATE	THRUST FACTOR	# HOLES	THREADED HOLE SIZE	BOLT CIRCLE FLANGE "A"	PTFE FLARE O.D. "B"	FLANGE THICKNESS	NOMINAL FLANGE O.D.	LIMIT BOLT DIAMETER	BOLT CIRCLE LIMIT BOLT "C"	LIMIT BOLT "EAR" O.D.	70°	100°	150°	200°	250°	300°	350°			400°	Hg at Temp.
		IN	IN	DEG.	LB <sub>f</sub> /IN	LB <sub>f</sub> /IN	LB <sub>f</sub> /IN																					
1.00	1.375	0.250	.125	7	104	80	104	2.76	4	1/2-13	3.125	2.000	.313	4.250	.250	5.125	6.000	185	170	148	130	115	100	84	68	29.9" @ 425°F	2	
1.25	1.375	0.250	.125	7	61	137	400	2.25	4	1/2-13	3.500	2.520	.394	4.630	.250	5.196	6.850	185	170	148	130	115	100	84	68	CF	5	
1.50	1.375	0.250	.125	7	320	180	224	4.60	4	1/2-13	3.875	2.875	.344	5.000	.250	5.875	6.750	185	170	148	130	115	100	84	68	29.9" @ 425°F	3	
2.00	1.563	0.250	.125	7	512	300	240	7.07	4	5/8-11	4.750	3.625	.438	6.000	.375	6.875	8.125	185	170	148	130	115	100	84	68	29.9" @ 425°F	7	
2.50	2.250	0.313	.125	7	457	278	328	9.62	4	5/8-11	5.500	4.125	.500	7.000	.375	8.125	9.375	185	170	148	130	115	100	84	68	29.9" @ 425°F	10	
3.00	2.250	0.375	.188	7	648	320	319	15.90	4	5/8-11	6.000	5.000	.500	7.500	.375	8.750	10.000	185	170	148	130	115	100	84	68	29.9" @ 425°F	10	
4.00	2.625	0.500	.250	7	480	280	400	23.75	8	5/8-11	7.500	6.188	.625	9.000	.375	9.875	11.125	185	170	148	130	115	100	84	68	29.9" @ 400°F	18	
5.00	3.250	0.500	.250	7	440	440	320	33.17	8	3/4-10	8.500	7.313	.750	10.000	.500	11.500	13.000	185	170	148	130	115	100	84	68	29.9" @ 400°F	24	
6.00	2.750	0.500	.250	7	440	386	440	50.24	8	3/4-10	9.500	8.500	.750	11.000	.500	12.500	14.000	185	170	148	130	115	100	84	68	29.9" @ 400°F	29	
8.00	4.000	0.500	.250	7	450	390	480	83.49	8	3/4-10	11.750	10.625	.938	13.500	.500	14.750	16.250	164	150	129	112	100	87	73	60	29.9" @ 250°F	47	
10.00	5.250	0.500	.250	7	760	600	580	108.38	12	7/8-9	14.250	12.750	1.000	16.000	.500	17.500	19.000	164	150	129	112	100	87	73	60	29.9" @ 250°F	64	
12.00	6.000	0.500	.250	7	1300	420	700	176.63	12	7/8-9	17.000	15.000	1.000	19.000	.625	20.500	22.000	70	59	48	40	35	30	26	22	29.9" @ 75°F	115	
14.00	6.313	0.750	.375	7	320	1056	1256	233.59	12	1-8	18.750	16.250	1.188	21.000	1.420	24.172	27.313	70	59	48	40	35	30	26	22	10.0" @ 212°F	126	
16.00	7.000	1.000	.375	7	297	1096	1256	259.68	16	1-8	21.250	18.500	1.188	23.500	1.420	27.563	31.500	70	59	48	40	35	30	26	22	10.0" @ 212°F	159	
18.00	7.938	1.000	.375	7	440	1941	1370	321.90	16	1 1/8-8	22.750	21.000	1.188	25.000	1.420	29.000	32.906	70	59	48	40	35	30	26	22	9.0" @ 212°F	174	
20.00	9.000	1.000	.375	7	—	—	—	374.57	20	1 1/8-8	25.000	23.000	1.188	27.500	1.420	31.500	35.438	70	59	48	40	35	30	26	22	6.0" @ 212°F	183	
24.00	6.313	0.625	.375	7	—	—	—	538.36	20	1 1/4-7	29.500	27.250	1.344	32.000	1.420	35.906	39.844	70	59	48	40	35	30	26	22	4.0" @ 212°F	238	

NOTES: 1. Movements are non-concurrent and based from Neutral Length with Limit Bolts installed.  
 2. Spring Rate Capability is based on 1" of movement at zero pressure conditions.  
 3. Vacuum Rating is based from fully extended position. CF = Contact Factory.



SERIES 442-BD MATERIALS OF CONSTRUCTION		
DESCRIPTION	1" THROUGH 12"	14" THROUGH 24"
BELLOWS	PTFE T-62	PTFE T-62
FLANGES	DUCTILE IRON	ZINC PLATED CARBON STEEL
REINFORCING RINGS	STAINLESS STEEL	STAINLESS STEEL
LIMIT BOLTS	CARBON STEEL	CARBON STEEL
NUTS	CARBON STEEL	CARBON STEEL

# PROCO™

## STYLE

# 443-BD

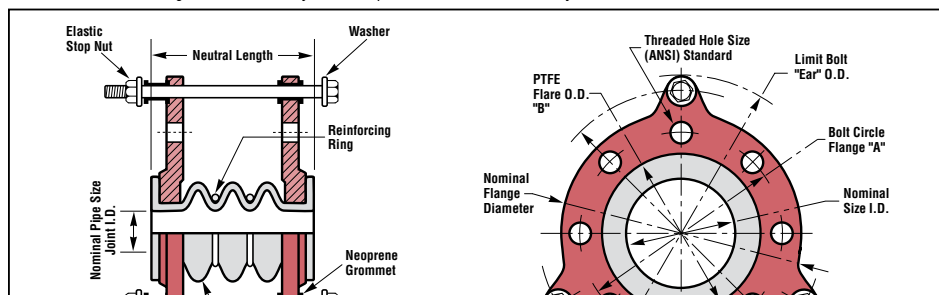


### molded PTFE expansion joints

**Table 2: Sizes • Movements • Spring Rates • Flange Standards • Temperatures • Vacuum • Weights**

NOMINAL SIZE I.D.	NEUTRAL LENGTH INCHES	MOVEMENT CAPABILITIES BASED ON THREE CONVOLUTION DESIGN <sup>1</sup>			SPRING RATE CAPABILITY <sup>2</sup>			THRUST FACTOR	EXPANSION JOINT FLANGE DRILLING							PRESSURE AT TEMPERATURE (PSIG) @ °F								VACUUM RATING <sup>3</sup>	WEIGHT / LBS		
		± AXIAL (Δx) MOVEMENT	LATERAL (Δy) DEFLECTION	ANGULAR DEFLECTION	COMPRESSION SPRING RATE	EXTENSION SPRING RATE	LATERAL SPRING RATE		# HOLES	THREADED HOLE SIZE	BOLT CIRCLE FLANGE "A"	PTFE FLARE O.D. "B"	FLANGE THICKNESS	NOMINAL FLANGE O.D.	LIMIT BOLT DIAMETER	BOLT CIRCLE LIMIT BOLT "C"	LIMIT BOLT "EAR" O.D.	70°	100°	150°	200°	250°	300°			350°	400°
		IN	IN	DEG.	LB <sub>f</sub> /IN	LB <sub>f</sub> /IN	LB <sub>f</sub> /IN																				
1.00	1.750	0.500	.250	14	190	82	96	2.81	4	1/2-13	3.125	2.000	.313	4.250	.250	5.125	6.000	138	126	107	90	76	64	53	45	29.9" @ 400°F	2
1.25	1.810	0.500	.250	14	40	120	314	2.25	4	1/2-13	3.500	2.520	.394	4.630	.250	5.196	6.850	128	120	96	85	72	56	42	36	CF	5
1.50	2.000	0.500	.250	14	84	66	108	5.09	4	1/2-13	3.875	2.875	.344	5.000	.250	5.875	6.750	138	126	107	90	76	64	53	45	29.9" @ 400°F	4
2.00	2.750	0.750	.375	14	69	76	109	9.11	4	5/8-11	4.750	3.625	.438	6.000	.375	6.875	8.125	138	126	107	90	76	64	53	45	29.9" @ 400°F	8
2.50	3.188	0.750	.375	14	91	97	160	11.41	4	5/8-11	5.500	4.125	.500	7.000	.375	8.125	9.375	138	126	107	90	76	64	53	45	29.9" @ 400°F	11
3.00	3.625	1.000	.500	14	124	125	194	16.91	4	5/8-11	6.000	5.000	.500	7.500	.375	8.750	10.000	138	126	107	90	76	64	53	45	29.9" @ 400°F	13
4.00	3.625	1.000	.500	14	220	155	264	25.40	8	5/8-11	7.500	6.188	.625	9.000	.375	9.875	11.125	138	126	107	90	76	64	53	45	29.9" @ 400°F	19
5.00	4.000	1.000	.500	14	320	210	324	34.45	8	3/4-10	8.500	7.313	.750	10.000	.500	11.500	13.000	138	126	107	90	76	64	53	45	29.9" @ 300°F	25
6.00	4.000	1.125	.563	14	289	187	266	50.24	8	3/4-10	9.500	8.500	.750	11.000	.500	12.500	14.000	138	126	107	90	76	64	53	45	29.9" @ 300°F	30
8.00	6.000	1.125	.563	14	178	218	423	83.49	8	3/4-10	11.750	10.625	.938	13.500	.500	14.750	16.250	120	110	94	80	67	57	47	38	29.9" @ 125°F	48
10.00	7.000	1.188	.500	14	420	531	857	128.55	12	7/8-9	14.250	12.750	1.000	16.000	.500	17.500	19.000	82	70	64	52	46	39	34	30	19.0" @ 212°F	60
12.00	7.875	1.188	.625	14	743	542	857	144.72	12	7/8-9	17.000	15.000	1.000	19.000	.625	20.500	22.000	82	70	64	52	46	40	34	30	10.0" @ 212°F	77
14.00	8.500	1.250	.688	14	239	628	970	233.59	12	1-8	18.750	16.250	1.188	21.000	1.420	24.172	27.313	82	70	64	52	46	40	34	30	10.0" @ 212°F	132
16.00	9.188	1.375	.750	14	245	571	970	259.68	16	1-8	21.250	18.500	1.188	23.500	1.420	27.563	31.500	82	70	64	52	46	40	34	30	10.0" @ 212°F	165
18.00	11.063	1.188	.750	14	—	—	1085	321.90	16	1 1/8-8	22.750	21.000	1.188	25.000	1.420	29.000	32.906	60	58	48	42	36	30	28	26	9.0" @ 212°F	201
20.00	12.875	1.188	1.000	14	—	—	1142	374.57	20	1 1/8-8	25.000	23.000	1.188	27.500	1.420	31.500	35.438	60	58	48	42	36	30	28	26	6.0" @ 212°F	243
24.00	11.875	1.000	.750	14	—	—	—	538.36	20	1 1/4-7	29.500	27.250	1.344	32.000	1.420	35.906	39.844	60	58	48	42	36	30	28	26	4.0" @ 212°F	309

NOTES: 1. Movements are non-concurrent and based from Neutral Length with Limit Bolts installed.  
 2. Spring Rate Capability is based on 1" of movement at zero pressure conditions.  
 3. Vacuum Rating is based from fully extended position. CF = Contact Factory.



SERIES 443-BD MATERIALS OF CONSTRUCTION		
DESCRIPTION	1" THROUGH 12"	14" THROUGH 24"
BELLOWS	PTFE T-62	PTFE T-62
FLANGES	DUCTILE IRON	ZINC PLATED CARBON STEEL
REINFORCING RINGS	STAINLESS STEEL	STAINLESS STEEL
LIMIT BOLTS	CARBON STEEL	CARBON STEEL
NUTS	CARBON STEEL	CARBON STEEL

**GOODYEAR**  
RUBBER PRODUCTS, INC.

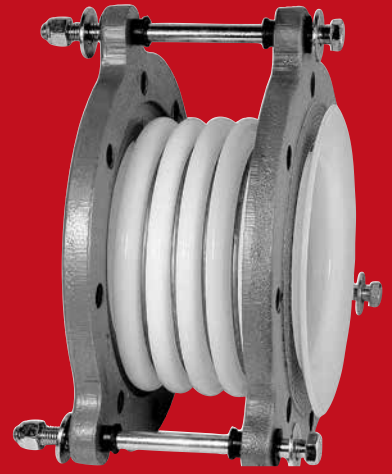
727-342-5088

You can also email us at  
GRP@goodyearrubberproducts.com

# PROCO™

## STYLE

# 445-BD

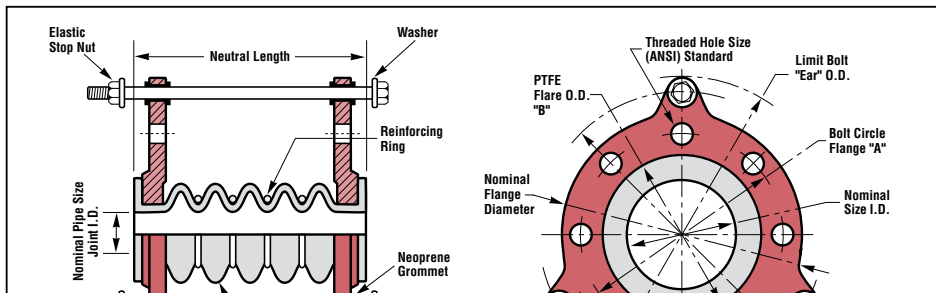


### molded PTFE expansion joints

**Table 3: Sizes • Movements • Spring Rates • Flange Standards • Temperatures • Vacuum • Weights**

NOMINAL SIZE I.D.	NEUTRAL LENGTH INCHES	MOVEMENT CAPABILITIES BASED ON FIVE CONVOLUTION DESIGN <sup>1</sup>				SPRING RATE CAPABILITY <sup>2</sup>			EXPANSION JOINT FLANGE DRILLING								PRESSURE AT TEMPERATURE (PSIG) @ °F								VACUUM RATING <sup>3</sup>	WEIGHT / LBS		
		± AXIAL (ΔX) MOVEMENT	LATERAL (ΔY) DEFLECTION	ANGULAR DEFLECTION	COMPRESSION SPRING RATE	EXTENSION SPRING RATE	LATERAL SPRING RATE	THRUST FACTOR	# HOLES	THREADED HOLE SIZE	BOLT CIRCLE FLANGE "A"	PTFE FLARE O.D. "B"	FLANGE THICKNESS	NOMINAL FLANGE O.D.	LIMIT BOLT DIAMETER	BOLT CIRCLE LIMIT BOLT "C"	LIMIT BOLT "EAR" O.D.	70°	100°	150°	200°	250°	300°	350°			400°	Hg at Temp.
		IN	IN	DEG.	LB <sub>f</sub> /IN	LB <sub>f</sub> /IN	LB <sub>f</sub> /IN																					
1.00	3.000	0.500	.500	20	30	44	22	2.81	4	1/2-13	3.125	2.000	.313	4.250	.250	5.125	6.000	72	61	46	40	34	29	27	24	NOT	2	
1.25	2.670	0.394	.470	20	36	114	171	2.25	4	1/2-13	3.500	2.520	.394	4.630	.250	5.196	6.850	62	56	42	36	30	26	22	22	NOT	5	
1.50	3.500	0.750	.500	20	75	83	46	5.09	4	1/2-13	3.875	2.875	.344	5.000	.250	5.875	6.750	72	61	46	40	34	29	27	24	NOT	5	
2.00	4.000	1.000	.500	20	60	47	50	9.11	4	5/8-11	4.750	3.625	.438	6.000	.375	6.875	8.125	72	61	46	40	34	29	27	24	DESIGNED	9	
2.50	4.600	0.980	.510	20	116	319	285	10.08	4	5/8-11	5.500	4.125	.500	7.000	.375	8.125	9.375	62	56	42	36	30	26	22	22	DESIGNED	11	
3.00	5.000	1.000	.500	20	55	60	170	16.91	4	5/8-11	6.000	5.000	.500	7.500	.375	8.750	10.000	72	61	46	40	34	29	27	24	DESIGNED	14	
4.00	5.250	1.250	.625	20	72	60	80	25.40	8	5/8-11	7.500	6.188	.625	9.000	.375	9.875	11.125	72	61	46	40	34	29	27	24	FOR	20	
5.00	6.000	1.250	.625	20	140	388	400	32.33	8	3/4-10	8.500	7.313	.750	10.000	.500	11.500	13.000	62	56	42	36	30	26	22	22	FOR	26	
6.00	6.000	1.250	.625	20	190	130	195	50.24	8	3/4-10	9.500	8.500	.750	11.000	.500	12.500	14.000	72	61	46	40	34	29	27	24	FOR	31	
8.00	8.000	1.250	.625	20	304	388	457	76.07	8	3/4-10	11.750	10.625	.938	13.500	.500	14.750	16.250	48	42	34	30	26	22	22	22	VACUUM	49	
10.00	8.750	1.250	.625	20	458	388	457	128.55	12	7/8-9	14.250	12.750	1.000	16.000	.500	17.500	19.000	48	42	34	30	26	22	22	22	VACUUM	64	
12.00	9.000	1.375	.688	20	529	445	457	144.72	12	7/8-9	17.000	15.000	1.000	19.000	.625	20.500	22.000	48	42	34	30	26	22	22	22	VACUUM	88	
14.00	12.790	1.375	.688	20	203	371	514	233.59	12	1-8	18.750	16.250	1.188	21.000	1.420	24.172	27.313	48	42	34	30	26	22	22	22	SERVICE	143	
16.00	13.500	1.625	1.000	20	180	383	514	259.68	16	1-8	21.250	18.500	1.188	23.500	1.420	27.563	31.500	48	42	34	30	26	22	22	22	SERVICE	179	
20.00	20.470	1.625	1.000	20	185	371	571	374.57	20	1 1/8-8	25.000	23.000	1.188	27.500	1.420	31.500	35.438	48	42	34	30	26	22	22	22	SERVICE	243	

NOTES: 1. Movements are non-concurrent and based from Neutral Length with Limit Bolts installed.  
 2. Spring Rate Capability is based on 1" of movement at zero pressure conditions.  
 3. Style 445-BD is not designed for Vacuum Service.



SERIES 445-BD MATERIALS OF CONSTRUCTION		
DESCRIPTION	1" THROUGH 12"	14" THROUGH 20"
BELLOWS	PTFE T-62	PTFE T-62
FLANGES	DUCTILE IRON	ZINC PLATED CARBON STEEL
REINFORCING RINGS	STAINLESS STEEL	STAINLESS STEEL
LIMIT BOLTS	CARBON STEEL	CARBON STEEL
NUTS	CARBON STEEL	CARBON STEEL

# Installation Instructions for Series 440 PTFE Expansion Joints

## TORQUE TABLE LISTING

SIZE I.D. (IN)	1.0	1.25	1.5	2.0	2.5	3.0	4.0	5.0	6.0	8.0	10.0	12.0
TORQUE (FT/LBS)	10	16	25	52	47	82	54	80	100	135	125	155
TOLERANCE (+/-)(FT/LBS)	2	3	6	13	11	20	13	20	24	32	31	38

Notes: 1. Bolt Torque requirements may vary depending on mating flange material and installation.  
2. "Over-Torque" may cause the PTFE material to creep.

**1. Service Conditions:** Make sure the expansion joint ratings for temperature, vacuum, spring rates and movements match the system requirements. Contact PROCO if the system requirements exceed those of the expansion joint selected.

**2. Alignment:** PROCO Series 440 PTFE expansion joints are not designed to make up for piping misalignment error. Pipe misalignment should be no more than 1/8" in any direction. Misalignment of an expansion joint will reduce the rated movements and can cause stress of material properties, thus causing reduced service life.

**3. Limit Bolts:** Limit bolts are factory set at the maximum allowable travel position to prevent over extension. Do not remove or alter nuts at any time. Damage or personal injury can result due to changes in limit bolt settings.

**4. Anchoring:** Solid anchoring is required whenever the pipeline changes direction. PROCO Series 440 PTFE expansion joints should be located as close as possible to these anchor points. If an anchoring system is not used, any associated pressure thrust can cause excessive movement, ultimately damaging the expansion joint. **(It should be noted that the attached limit bolts/cables are designed to limit movement and are not designed to handle pressure thrust.)**

**5. Pipe Support:** Piping must be supported by hangers or anchors so expansion joints do not carry any pipe weight.

**6. Personnel Protection:** It is strongly recommended that spray shields be used for all hazardous service to protect against serious personal injury in the event of expansion joint failure. (Contact PROCO for spray shield information.)

**7. Installation:**

**a.** Store expansion joints with wood covers in-place to protect PTFE flange surfaces from damage until ready to install.

**b.** Check to make sure PTFE surfaces are clean and free of foreign sediment. Remove nicks, burrs and deep scratches with a fine emery cloth. If surface irregularities cannot be completely removed, install a PTFE envelope-type gasket to obtain an adequate seal.

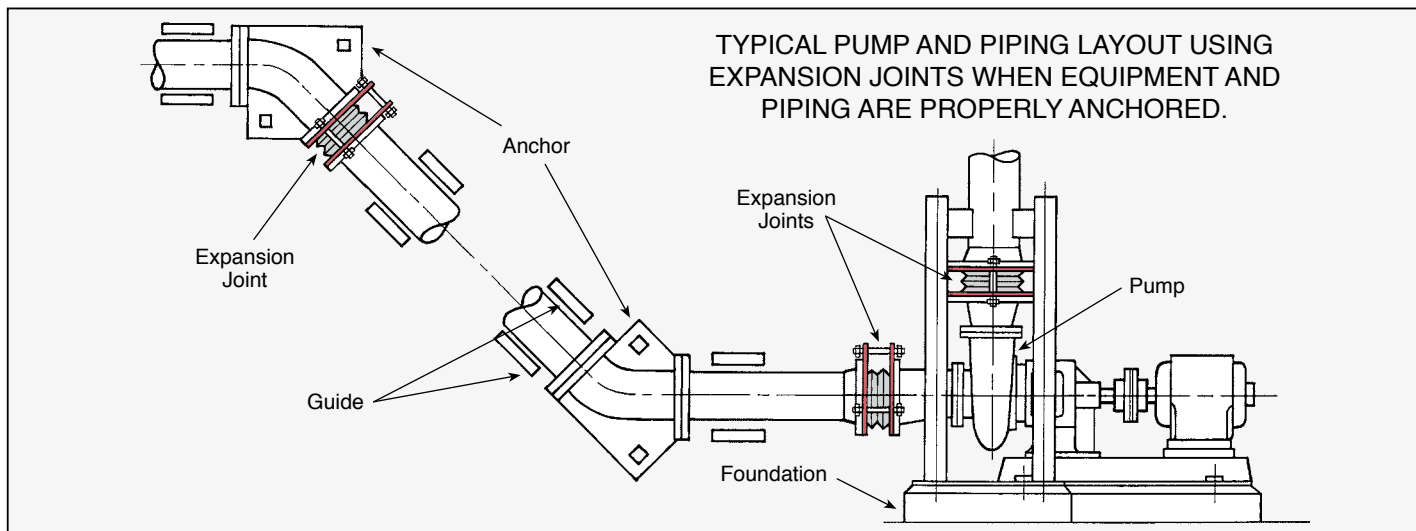
**c.** Install the PROCO Series 440 PTFE expansion joints to the prescribed neutral lengths. If expansion joints are used in high temperature processes, it is recommended that units be installed at/near the extended values. For cold process installations, expansion joints should be installed in a nearly compressed length. These settings will enable the expansion joint to realize full travel capabilities. (See appropriate Tables for Neutral Lengths.)

**d.** Thread installation bolts from mating flange side to prevent possible damage to PTFE elements. Extend bolts beyond the expansion joint flange by no more than 1-2 threads. Nuts are not necessary due to threaded flange holes.

**e.** Tighten flange bolts with a torque wrench. Tighten in an alternate crossing pattern in 20% increments until 80% of final bolt torques have been achieved. Tighten to final torque values (listed in Torque Table Listing) in a clockwise fashion around the flange to ensure bolts carry equal stress burdens.

**f.** Re-tighten bolts after first cycle of operation. Re-tighten as necessary after every planned maintenance shutdown. All bolts should be re-torqued to the above listed values.

**8. Operations:** After expansion joints are installed, it may be necessary to air blast the exterior to remove foreign debris, such as metal chips, from between the convolutions. The expansion joint should then be covered with a shield to protect from damage and foreign debris during operation. **(Note: Do not weld in immediate vicinity of expansion joint unless it is properly protected.)**



**ENGINEERING DESIGN NOTES:**

1. It is essential that piping system thrusts be calculated to ensure correct sizing of anchors and pipe supports, plus ensure that allowable thrust forces on adjacent mechanical and rotating equipment are not exceeded. Please use the following formulas:

$$T_p = P \cdot T_f$$

$T_p$  is the pressure thrust (lb<sub>f</sub>),  $P$  is the system operating pressure (Psia),

$$R_x = T_p + (F_x \cdot \Delta x)$$

$R_x$  is the pipe support reaction force (lb<sub>f</sub>),  $T_p$  is the pressure thrust (lb<sub>f</sub>),  $F_x$  is the axial spring force of the unit and  $\Delta x$  is the expected or designed axial movement of the unit (See Tables 1-3).

2. It should be noted that axial spring rate values found in Tables 1-

# We Cover The World!



## **PROCO PRODUCTS, INC.** **The Expansion Joint People**

***Demand the best — insist on PROCO!***

- Knowledgeable sales staff that has an average of 20 years experience with expansion joints
- Daily UPS® pick-up
- Preselected freight carriers to minimize “interline transfer”
- Emergency service for nights, weekends, and even holidays
- Complete expansion joint product line
- Largest inventory in North America with warehouses in Stockton, CA  
Houston, TX  
Atlanta, GA



2431 North Wigwam Drive  
Stockton, California 95205  
Post Office Box 590  
Stockton, California 95201-0590 USA

DISTRIBUTED BY:

**GOODYEAR**  
RUBBER PRODUCTS, INC.

☎ 727-342-5088

You can also email us at  
[GRP@goodyearrubberproducts.com](mailto:GRP@goodyearrubberproducts.com)

# PROCO

The Expansion Joint and Check Valve People

## SERIES 450

### Sleeve Type Pipe Connectors

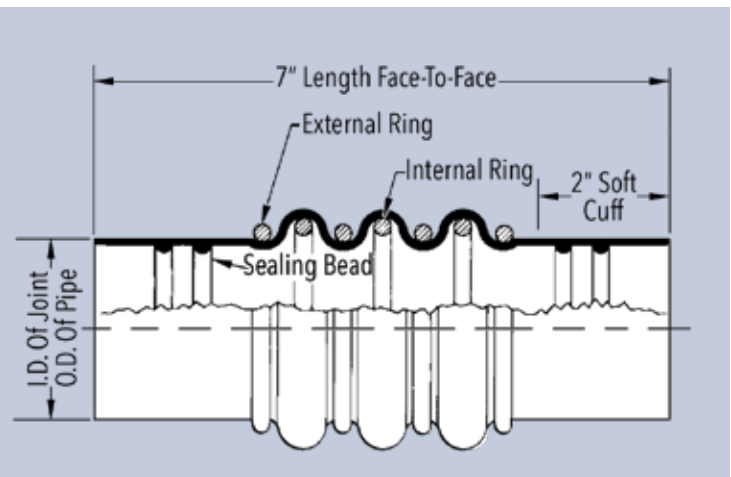


The PROCO Series 450 Sleeve Type Pipe Connectors are used for tough demanding applications found in: Refrigeration Pump Systems, Industrial Process Piping Systems, Power Generating Plant Pump Systems, Pulp/Paper Plant Pump Systems, Water-Wastewater Sewage and control systems where lower pressure and sleeve ends are used in lieu of flanged spool type rubber expansion joints. The Series 450 Sleeve Type Pipe Connectors are constructed of Neoprene rubber and reinforced with impregnated woven nylon.

Specify the PROCO Series 450 for installations near mechanical equipment in piping systems to: (1) Absorb Pipe/Movement/ Stress, (2) Reduce system Noise, (3) Isolate Vibration, (4) Eliminate Electrolysis, (5) Compensate Alignment/Offset & (6) Protect Against Start-Up/Surge Forces. Our history in expansion joint products dates back to 1930. When you need an engineered solution to a piping systems problem, call PROCO.

**Construction of Sleeve Type Pipe Connectors:** The Series 450 Sleeve Type Connectors are constructed of neoprene rubber and reinforced with impregnated woven nylon. Sealing beads are molded on the interior of the sleeve and provide extra sealing action for the clamping area. Internal reinforcing rings prevent deformation of the connector during surge or temporary negative pressure conditions. The outer reinforcement rings are provided to add external reinforcement.

**Fastening Method:** The Series 450 Sleeve Type Pipe Connectors require heavy duty, stainless steel, 1" wide "T" bolt clamps to provide proper clamping strength. Clamps are not stocked by PROCO Products, Inc. and are to be provided by others.



**"The Expansion Joint & Check Valve People"**



**Protecting Piping and Equipment Systems from Stress/Motion**

**GOODYEAR**  
RUBBER PRODUCTS, INC.

☎ 727-342-5088

You can also email us at  
[GRP@goodyearrubberproducts.com](mailto:GRP@goodyearrubberproducts.com)

# SERIES 450

## Sleeve Type Pipe Connectors

Dimensions			Allowable Movements			Operating Conditions			Force To Move (Lbs.)		Wt.-Lbs.
Nominal Pipe Size	O.D. Of Pipe I.D. Of Joint	Length of Joint	Axial		Angular $\pm$ Degrees	Pressure (PSIG) <sup>1</sup>	Vacuum (In. Hg.)	Temp F° <sup>2</sup>	Axial Extension	Axial Compression	Sleeve
			Extension	Compression							
1.5	1.900	7.0	.5	1.0	10°	75	20	225	30	26	1.4
2.0	2.375	7.0	.5	1.0	10°	75	20	225	35	30	1.6
2.5	2.875	7.0	.5	1.0	10°	75	20	225	40	34	1.8
3.0	3.5	7.0	.5	1.0	10°	75	20	225	45	40	2.0
3.5	4.0	7.0	.5	1.0	10°	75	20	225	48	43	2.2
4.0	4.5	7.0	.5	1.0	10°	75	20	225	50	45	2.4
4.5	5.0	7.0	.5	1.0	10°	75	20	225	53	52	2.7
5.0	5.563	7.0	.5	1.0	10°	75	20	225	57	60	2.9
6.0	6.625	7.0	.5	1.0	10°	75	20	225	65	75	3.4
8.0	8.625	7.0	.5	1.0	10°	75	20	225	100	145	4.3
10.0	10.750	7.0	.5	1.0	10°	75	20	225	265	255	5.1
12.0	12.750	7.0	.5	1.0	10°	75	20	225	650	400	6.7

Coupling to be slipped over pipe to a depth of 2".  
Coupling is a flexible member, and pipe must be properly anchored and guided.  
All dimensions are in inches.

Notes:  
1. Burst pressure rated at four times operating pressure.  
2. Can withstand an intermittent temperature of 275° F.

The largest inventory in North America!

### PROCO PRODUCTS, INC.

PROCO has a vast array of Style/Elastomer configurations. We have an inventory to 72" diameter and can ship your requirement the same business day. With over 16 years of average experience in the expansion joint industry, our sales staff can answer any of your questions and help to solve your problems.



"The Expansion Joint & Check Valve People"  
**Speed Is Our Strength!**

- Same-day shipping
- Knowledgeable sales staff that has an average of 16 years experience with expansion joints
- Daily UPS® and YRC® pick-up
- Preselected freight carriers to minimize "interline transfer"
- Emergency service for nights, weekends, and even holidays
- Complete expansion joint product line
- Largest inventory in North America



2431 North Wigwam Dr. (95205)  
P.O. Box 590 • Stockton, CA  
95201-0590 • USA

Distributed By:

**GOODYEAR**  
RUBBER PRODUCTS, INC.

☎ 727-342-5088

You can also email us at  
[GRP@goodyearrubberproducts.com](mailto:GRP@goodyearrubberproducts.com)

# PROCO™

## SERIES 500

### non-metallic flexible fan connectors

The PROCO Series 520, Series 530, and Series 540 non-metallic connectors are designed to match inlet and outlet flanges of most industrial fan manufacturers and are found in: Ventilating Systems, Industrial Process Ducting Systems, Chemical-Petrochemical Plants, Power Generating Plants, Pulp/Paper Plants, Water-Waste Water Sewage and Odor Control Ducting Systems. Specify the PROCO Series 520, Series 530 and Series 540 non-metallic connectors for installation between anchor points or next to mechanical equipment such as: Fans, Blowers, Compressors and Hot Air Ducts. The PROCO Series 500 non-metallic flexible connectors are designed to: (1) Absorb Ducting Movements, (2) Reduce System Noise, (3) Isolate Vibration, (4) Compensate Alignment/Offset. Our history in the manufacture of expansion joint products dates back to 1930. When an engineered solution is needed to solve a ducting problem, call PROCO.

**Engineered For Your Application:** The PROCO Series 500 non-metallic connectors are available in U-Designs, Arch-Designs and W-Designs. Each style offers different movement and pressure ratings to fit required specification. Available styles include:

- **Style 520:** Known as a U-Type, this integrally flanged non-metallic connector is found in applications where large movements are required and where vibration and sound absorption are needed. This non-metallic fan connector can be manufactured in both round and rectangular shapes.
- **Style 530:** Known as an Arch-Type, this integrally flanged non-metallic connector is found in applications where large movements and short overall lengths are required. Primarily used for Clean Hot Air/Gas Service, the Style 530 is designed with a high profile molded arch, giving it exceptional movement capabilities. This non-metallic connector can be manufactured in both round and rectangular shapes.
- **Style 540:** Known as a W-Type, this integrally flanged non-metallic connector is found in applications where large movements are required for Standard Hot Air/Gas Service. The Style 540 is designed with a molded radius allowing for greater movement capability and should be used when the U-Type (520) does not meet movement specifications. This non-metallic connector can be manufactured in both round and rectangular shapes.
- **Other Styles Available From PROCO Include:** Style 501 (Flat Belt Type), Style 502 (Flat Belt Arch-Type) and 190-K Navy Fan Connector (U-Type or Arch-Type). These styles are included in this brochure.

**Retaining Rings/Backing Bars.** Retaining rings (round) or backing bars (rectangular) are required for Series 500 non-metallic connectors and can be furnished by PROCO upon request. Standard construction calls for 2" wide by 3/8" thick carbon steel bars drilled to customer specifications. Other materials of construction can be provided upon request. In addition, PROCO can also supply T-Bolt Latch Clamps for round applications under 20" ID.

**Available Fabric Materials.** PROCO can manufacture the Series 500 non-metallic connectors in a wide selection of materials which include Chlorobutyl, Neoprene, Hypalon®, EPDM and Viton®. Material selection is dependent upon application. Consult the PROCO "Chemical to Elastomer Guide" (available upon request) for appropriate selection of materials.

**Information • Ordering • Pricing • Delivery.** Day or night, weekends and holidays ... the PROCO phones are monitored 24 hours around the clock. When you have a question, you can call us.

Toll-Free Phone . . . . . 800 / 344-3246 USA/CANADA

International Calls . . . . . 209 / 943-6088

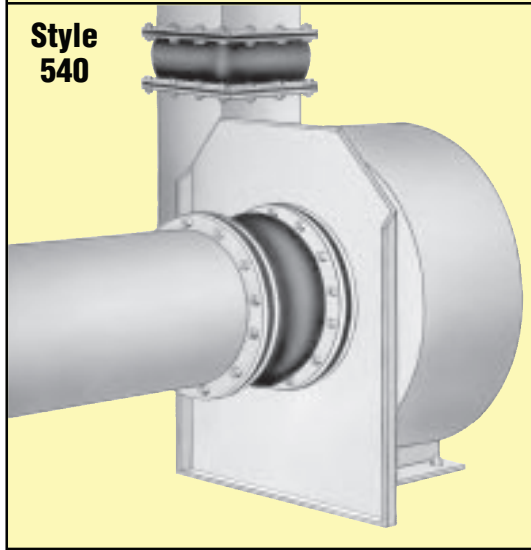
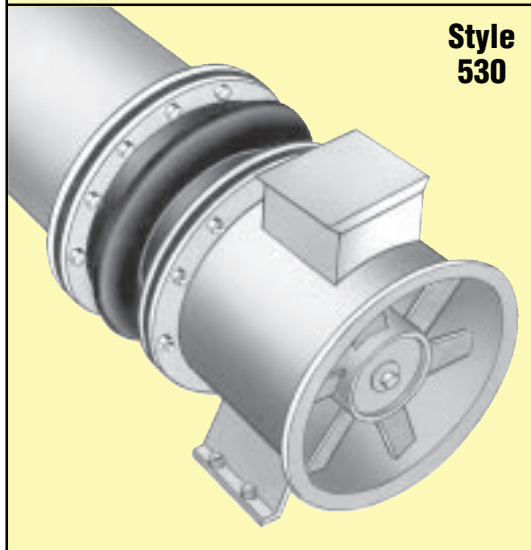
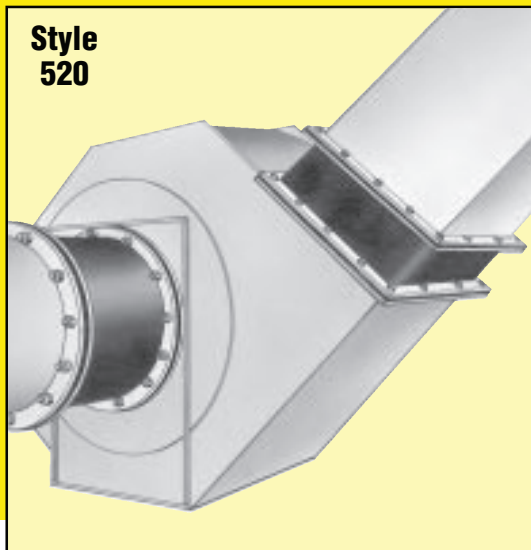
Fax . . . . . 209 / 943-0242

E-mail . . . . . sales@procoproducts.com

Web Site . . . . . www.procoproducts.com

Weekday office hours are 5:30 a.m. to 5:15 p.m. Pacific Time.

Hypalon and Viton are registered trademarks of DuPont Dow Elastomers.



Rev. 12/11

*The Expansion Joint People*

*Protecting Ducting And Equipment Systems From Stress/Motion*

**GOODYEAR**  
RUBBER PRODUCTS, INC.

☎ 727-342-5088

You can also email us at  
[GRP@goodyearrubberproducts.com](mailto:GRP@goodyearrubberproducts.com)

# PROCO™

## SERIES 500

**non-metallic flexible fan/duct connectors**

**Style 501**  
flat belt type

**Style 502**  
flat belt arch-type

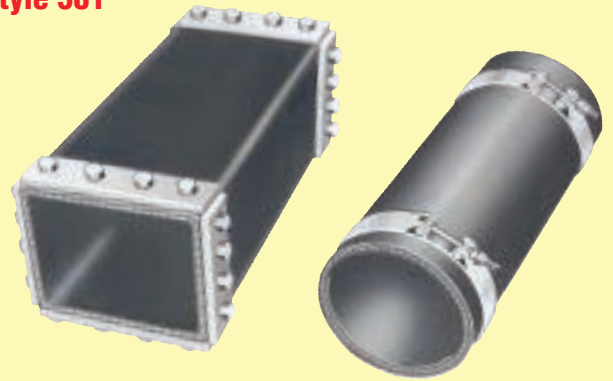
**Style 190-K**  
navy fan connector

**Style 501:** Known as a “Flat Belt Type”, this non-metallic connector is primarily used for low pressure vibration applications and can be attached to existing metal frames or duct work. The PROCO Series 500, Style 501 duct connector can be manufactured in round or rectangular shapes and can be attached to metal surfaces using clamps (round applications), or backing bars (rectangular applications). The Style 501 can be manufactured in a variety of elastomers and can be sent to the field spliced endless and/or prepared for cold field splice. See Table 1 for material considerations.

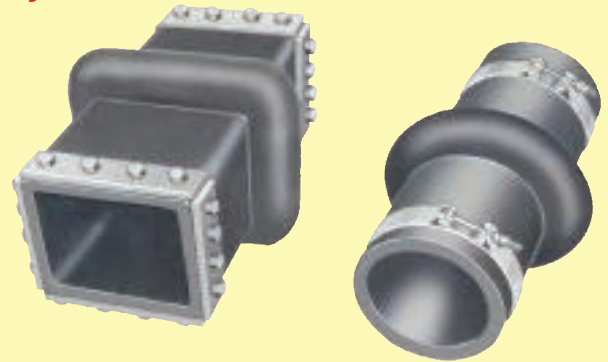
**Style 502:** Known as a “Flat Belt Arch-Type”, this non-metallic connector is used for low pressure applications where movements are required and can be attached to existing metal frames or duct work. The PROCO Series 500, Style 502 duct connector can be manufactured in round or rectangular shapes and can be attached to metal surfaces using clamps (round applications), retaining rings (round applications), or backing bars (rectangular applications). The Style 502 Flat Belt Arch-Type can be manufactured in a variety of elastomers and can be sent to the field in an endless connection only. See Table 1 for material considerations.

**Style 190-K:** Known as a “Navy Fan Connector”, the Style 190K is manufactured of 3/16" thick polyester fabric reinforced neoprene MIL-R-6855, Class 2, Durometer 40. The Style 190-K Navy Fan Connector can be manufactured in U-Type or Arch-Type forms depending upon application requirements. U-Type connectors can be manufactured with a minimum 3" face-to-face overall length. Arch-Type connectors can be manufactured with a minimum 6" face-to-face overall length. PROCO can manufacture the Series 500, Style 190-K in both round and rectangular shapes. If flange drilling is required for the Style 190-K Navy Fan Connectors, PROCO can drill per customer's specifications. Retaining rings and/or backing bars can be furnished (drilled or undrilled) upon request. See Table 1 for material considerations.

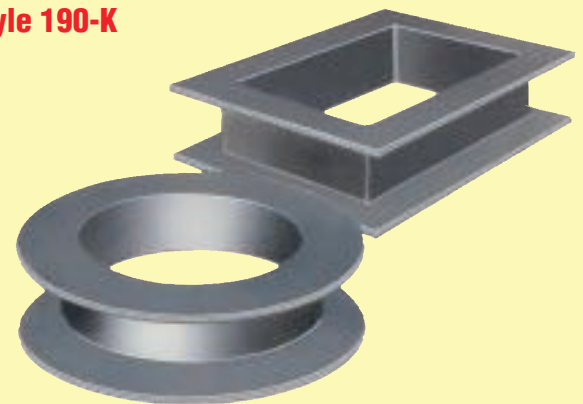
**Style 501**



**Style 502**



**Style 190-K**



**Table 1: Available Styles /Materials**

For Specific Elastomer Recommendations, See: PROCO™ “Chemical To Elastomer Guide”					
Styles	PROCO Material Code	Elastomer	Nominal Body Thickness	No. of Reinforcement Plies <sup>1</sup>	Maximum Pressure Rating (PSI) <sup>2</sup>
501	BB	Chlorobutyl	3/16"	1	±1
	EE	EPDM			
	HH	Hypalon®			
	NH	Neoprene/Hypalon®	1/4"	2	±2
	NN	Neoprene			
	NP	Neoprene/Buna-N			
VV	Viton®	3/8"	2	±2	
502	BB	Chlorobutyl	3/16"	1	±1
	EE	EPDM			
	HH	Hypalon®			
	NH	Neoprene/Hypalon®	1/4"	2	±2
	NN	Neoprene			
	NP	Neoprene/Buna-N			
VV	Viton®	3/8"	2	±2	
190-K	NN	Neoprene	3/16"	1	±2
	VV	Viton®			

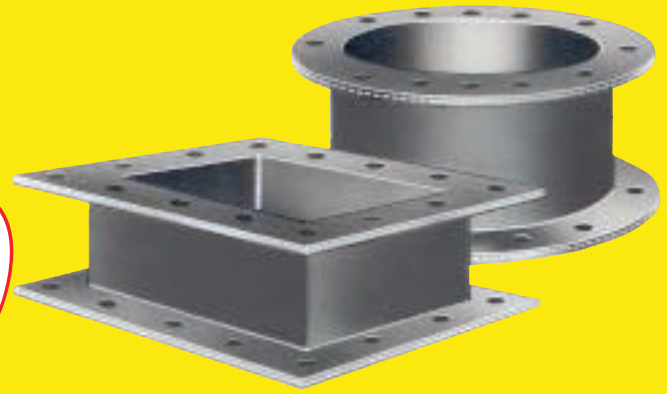
Hypalon and Viton are registered trademarks of DuPont Dow Elastomers  
Expansion Joint “Cover” (outside) can be Hypalon painted on special order.

NOTES: 1. Standard fabric reinforcement is polyester. Other high temperature materials are available upon request.  
2. For vacuum applications, all fabric elements should retain sufficient setback from the duct to ensure that belting does not protrude into the flow stream.

# PROCO™

## STYLE 520

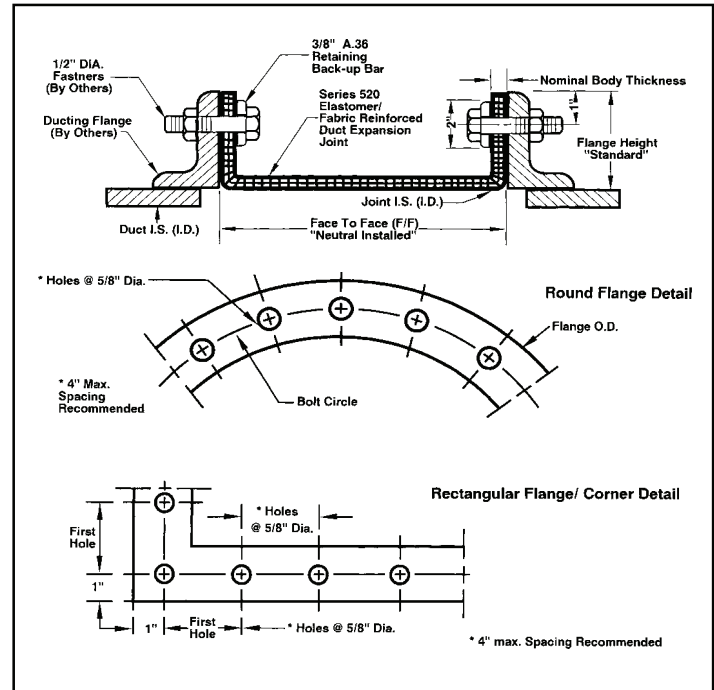
### U-DESIGN for standard movements



**PROCO Style 520 U-Type Fan/Duct Connectors:** The most economical of the integrally flanged designs, the Style 520 is predominately used for fan vibration applications. The fan/duct connector is manufactured in a U-Design configuration with a minimum of one (1) to two (2) plies of reinforced fabric vulcanized into a homogeneous product that is 3/16", 1/4" or 3/8" thick. The Style 520 is manufactured with continuous corners. No splices will be made in the corner areas. Listed below is information regarding the Style 520 non-metallic fan/duct connectors:

**System Design Considerations:** In designing the Series 500, Style 520 non-metallic fans/duct connector, several considerations must be taken into account to ensure long lasting service.

- **System Media:** The designer and/or requesting party should define the system media to determine the correct elastomer for each application. Evaluation of the gas/air composition should be made during design of the non-metallic fan/duct connector. Abrasion characteristics and external environment conditions should also be taken into account when specifying the fabric element.
- **System Temperature:** The system operating temperature is of primary importance to the design of a non-metallic fan/duct connector, although the system design is generally specified. It is important to distinguish between operating and design as "design" can include a significant safety factor which may result in an upgraded material or design selection.
- **System Pressure:** Normal operating pressures and maximum pressures (positive and negative) under upset conditions should be specified. Combinations of pressures and temperatures should be specifically identified.
- **Movements:** Movements consist of thermal growth resulting from both operating and upset conditions. Individual movements resulting from both conditions should be specified. Maximum installation misalignment should also be taken into account to determine if the non-metallic fan/duct connector design is capable of reacting to a combination of the total maximum movements.



Style 520 Available Materials							
For Specific Elastomer Recommendations, See: PROCO™ "Chemical To Elastomer Guide"							
Styles	PROCO Material Code	Elastomer	Nominal Body Thickness	No. of Reinforcement Plies <sup>1</sup>	Maximum Operating Temp °F	Maximum Pressure Rating (PSI) <sup>2</sup>	
520	BB	Chlorobutyl	3/16"	1	300°	±2	
	EE	EPDM			300°		
	HH	Hypalon®			225°		
	NH	Neoprene/Hypalon®	1/4"	2	225°		±3
	NN	Neoprene	3/8"	2	212°		
	NP	Neoprene/Buna-N			212°		
VV	Viton®	400°					

Hypalon and Viton are registered trademarks of DuPont Dow Elastomers  
Expansion Joint "Cover" (outside) can be Hypalon painted on special order.  
NOTES: 1. Standard fabric reinforcement is polyester. Other high temperature materials are available upon request.  
2. For vacuum applications, all fabric elements should retain sufficient setback from the duct to ensure that belting does not protrude into the flow stream.

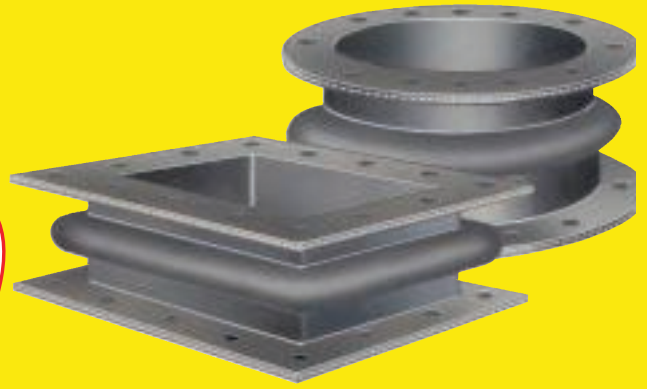
Non-Metallic Fan/Duct Connector Weight (pounds per square foot of periphery)								
Nominal Body Thickness	Elastomers							Retaining Rings/Bars Linear/Foot
	Chloro-butyl	EPDM	Hypalon®	Neoprene/Hypalon®	Neoprene	Neoprene/Buna-N	Viton®	
1/4"	1.6	1.6	1.8	1.8	1.8	1.8	2.5	3.5
3/8"	2.5	2.5	2.6	2.6	2.6	2.6	4.8	

Maximum Movement Capabilities								
6" Face To Face			9" Face To Face			12" Face To Face		
Axial Compression (inches)	Axial Extension (inches)	Lateral Offset (inches)	Axial Compression (inches)	Axial Extension (inches)	Lateral Offset (inches)	Axial Compression (inches)	Axial Extension (inches)	Lateral Offset (inches)

Design Data Sheet Fan/Duct Connector - Style 520		
Item	Application	Size
Tag No.:		
Quantity:		
Equipment Adjacent The Connector:		
Media: Gas or Air (circle one)	G A	
Location of Joint: (Inlet, Discharge, Bypass)		
Duct I.S. or Diameter:		
Face To Face:		IN.
Operating:		°F
Design:		°F
Operating:		PSI
Design:		PSI
Axial Compression:		IN.
Axial Extension:		IN.

# PROCO™

# STYLE 530

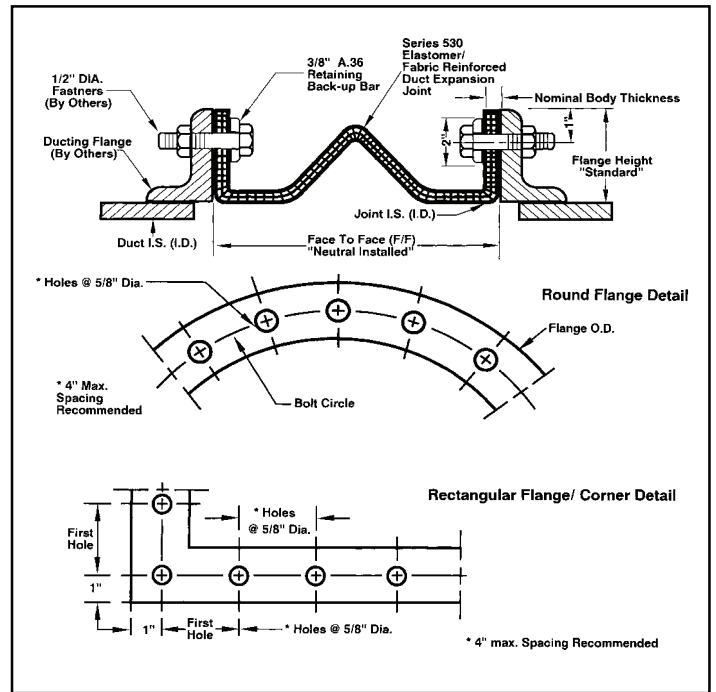


## ARCH-DESIGN for ultra high movements

**PROCO Style 530 Arch-Type Duct Connectors:** The least economical of the integrally flanged designs, the Style 530 is predominately used for applications where movements are large and face-to-face space is a premium. The duct connector is manufactured in an Arch-Design configuration with a minimum of one (1) to two (2) plies of reinforced fabric vulcanized into a homogeneous product that is 3/16", 1/4" or 3/8" thick. The flanges shall be an integral part of the expansion joint. The Style 530 is manufactured with a preformed arch. The arch continues through the corner and straight sections and shall be fully developed when in the neutral installation position. Listed below is information regarding the Style 530 non-metallic duct connectors:

**System Design Considerations:** In designing the Series 500, Style 530 non-metallic duct connector, several considerations must be taken into account to ensure long lasting service.

- **System Media:** The designer and/or requesting party should define the system media to determine the correct elastomer for each application. Evaluation of the gas/air composition should be made during design of the non-metallic fan/duct connector. Abrasion characteristics and external environment conditions should also be taken into account when specifying the fabric element.
- **System Temperature:** The system operating temperature is of primary importance to the design of a non-metallic fan/duct connector, although the system design is generally specified. It is important to distinguish between operating and design as "design" can include a significant safety factor which may result in an upgraded material or design selection.
- **System Pressure:** Normal operating pressures and maximum pressures (positive and negative) under upset conditions should be specified. Combinations of pressures and temperatures should be specifically identified.
- **Movements:** Movements consist of thermal growth resulting from both operating and upset conditions. Individual movements resulting from both conditions should be specified. Maximum installation misalignment should also be taken into account to determine if the non-metallic fan/duct connector design is capable of reacting to a combination of the total maximum movements.



Style 530 Available Materials						
For Specific Elastomer Recommendations, See: PROCO™ "Chemical To Elastomer Guide"						
Styles	PROCO Material Code	Elastomer	Nominal Body Thickness	No. of Reinforcement Plies <sup>1</sup>	Maximum Operating Temp °F	Maximum Pressure Rating (PSI) <sup>2</sup>
530	BB	Chlorobutyl	3/16"	1	300°	±2
	EE	EPDM			300°	
	HH	Hypalon®	225°	2	±3	
	NH	Neoprene/Hypalon®				
	NN	Neoprene	212°	2	±5	
	NP	Neoprene/Buna-N	212°			
VV	Viton®	400°				

Hypalon and Viton are registered trademarks of DuPont Dow Elastomers  
Expansion Joint "Cover" (outside) can be Hypalon painted on special order.  
NOTES: 1. Standard fabric reinforcement is polyester. Other high temperature materials are available upon request.  
2. For vacuum applications, all fabric elements should retain sufficient setback from the duct to ensure that belting does not protrude into the flow stream.

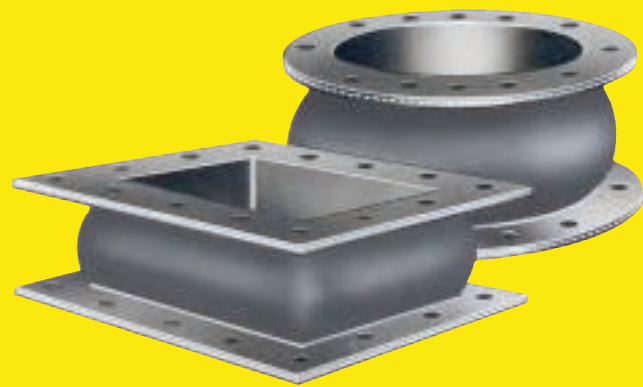
Non-Metallic Fan/Duct Connector Weight (pounds per square foot of periphery)								
Nominal Body Thickness	Elastomers							Retaining Rings/Bars Linear/Foot
	Chloro-butyl	EPDM	Hypalon®	Neoprene/Hypalon®	Neoprene	Neoprene/Buna-N	Viton®	
1/4"	1.6	1.6	1.8	1.8	1.8	1.8	2.5	3.5
3/8"	2.5	2.5	2.6	2.6	2.6	2.6	4.8	

Maximum Movement Capabilities								
6" Face To Face			9" Face To Face			12" Face To Face		
Axial Compression (inches)	Axial Extension (inches)	Lateral Offset (inches)	Axial Compression (inches)	Axial Extension (inches)	Lateral Offset (inches)	Axial Compression (inches)	Axial Extension (inches)	Lateral Offset (inches)

Design Data Sheet Fan/Duct Connector - Style 530		
Item		
Tag No.:		
Quantity:		
Equipment Adjacent The Connector:		
Media: Gas or Air (circle one)	G	A
Location of Joint: (Inlet, Discharge, Bypass)		
Duct I.S. or Diameter:		
Face To Face:	IN.	
Temperature	Operating:	°F
	Design:	°F
Pressure	Operating:	PSI
	Design:	PSI
Movements	Axial Compression:	IN.

# PROCO™

## STYLE 540

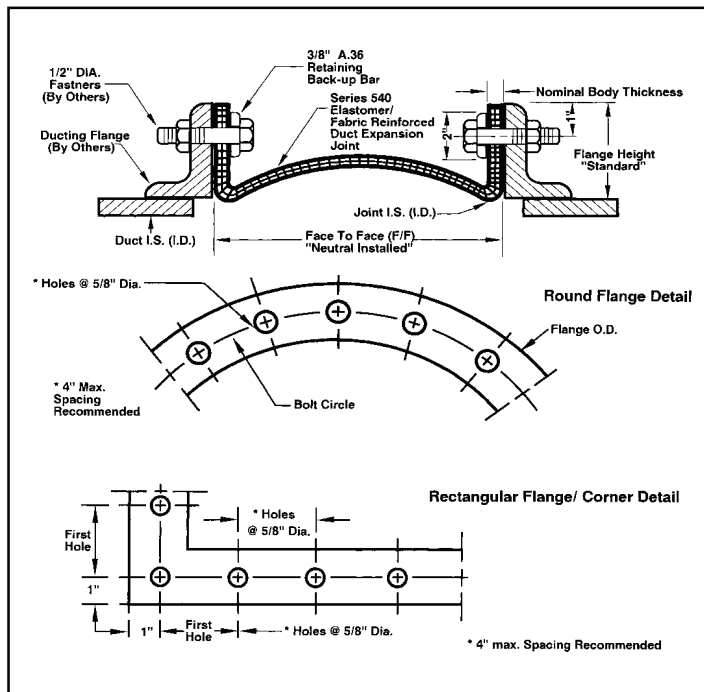


### W-DESIGN for maximum movements

**PROCO Style 540 W-Type Duct Connectors:** An economical integrally flanged design, the Style 540 is predominately used for applications where there are large movements. The duct connector is manufactured in a W-Design configuration with a minimum of one (1) to two (2) plies of reinforced fabric vulcanized into a homogeneous product that is 3/16", 1/4" or 3/8" thick. The flanges shall be an integral part of the expansion joint. The Style 540 is manufactured with a premolded arch. The arch continues through the corner and shall be fully developed when in the neutral position. Listed below are considerations regarding the design of the Style 540 non-metallic duct connectors:

**System Design Considerations:** In designing the Series 500, Style 540 non-metallic duct connector, several considerations must be taken into account to ensure long lasting service.

- **System Media:** The designer and/or requesting party should define the system media to determine the correct elastomer for each application. Evaluation of the gas/air composition should be made during design of the non-metallic fan/duct connector. Abrasion characteristics and external environment conditions should also be taken into account when specifying the fabric element.
- **System Temperature:** The system operating temperature is of primary importance to the design of a non-metallic fan/duct connector, although the system design is generally specified. It is important to distinguish between operating and design as "design" can include a significant safety factor which may result in an upgraded material or design selection.
- **System Pressure:** Normal operating pressures and maximum pressures (positive and negative) under upset conditions should be specified. Combinations of pressures and temperatures should be specifically identified.
- **Movements:** Movements consist of thermal growth resulting from both operating and upset conditions. Individual movements resulting from both conditions should be specified. Maximum installation misalignment should also be taken into account to determine if the non-metallic fan/duct connector design is capable of reacting to a combination of the total maximum movements.



Style 540 Available Materials						
For Specific Elastomer Recommendations, See: PROCO™ "Chemical To Elastomer Guide"						
Styles	PROCO Material Code	Elastomer	Nominal Body Thickness	No. of Reinforcement Plies <sup>1</sup>	Maximum Operating Temp °F	Maximum Pressure Rating (PSI) <sup>2</sup>
540	BB	Chlorobutyl	3/16"	1	300°	±2
	EE	EPDM			300°	
	HH	Hypalon®	225°			
	NH	Neoprene/Hypalon®	225°	±3		
	NN	Neoprene	212°			
	NP	Neoprene/Buna-N	212°	±5		
VV	Viton®	400°				

Hypalon and Viton are registered trademarks of DuPont Dow Elastomers  
Expansion Joint "Cover" (outside) can be Hypalon painted on special order.  
NOTES: 1. Standard fabric reinforcement is polyester. Other high temperature materials are available upon request.  
2. For vacuum applications, all fabric elements should retain sufficient setback from the duct to ensure that belting does not protrude into the flow stream.

Non-Metallic Fan/Duct Connector Weight (pounds per square foot of periphery)								
Nominal Body Thickness	Elastomers							Retaining Rings/Bars Linear/Foot
	Chloro-butyl	EPDM	Hypalon®	Neoprene/Hypalon®	Neoprene	Neoprene/Buna-N	Viton®	
1/4"	1.6	1.6	1.8	1.8	1.8	1.8	2.5	3.5
3/8"	2.5	2.5	2.6	2.6	2.6	2.6	4.8	

Maximum Movement Capabilities								
6" Face To Face			9" Face To Face			12" Face To Face		
Axial Compression (Inches)	Axial Extension (Inches)	Lateral Offset (Inches)	Axial Compression (Inches)	Axial Extension (Inches)	Lateral Offset (Inches)	Axial Compression (Inches)	Axial Extension (Inches)	Lateral Offset (Inches)

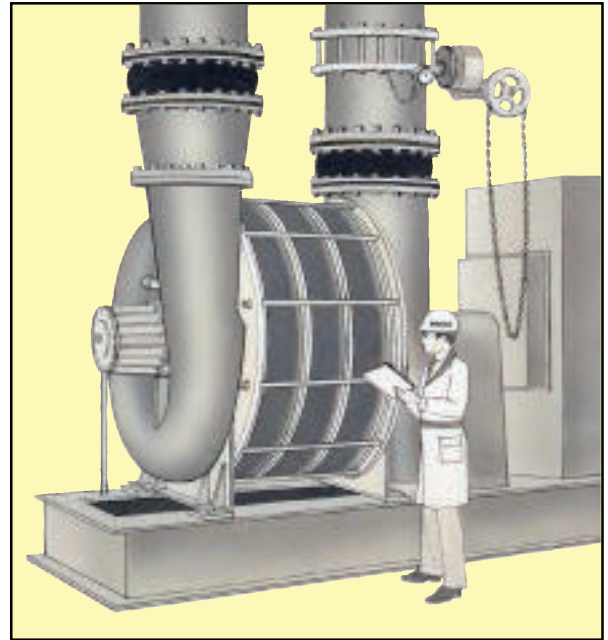
Design Data Sheet Fan/Duct Connector - Style 540	
Item	
Tag No.:	
Quantity:	
Equipment Adjacent The Connector:	
Media: Gas or Air (circle one)	G      A
Location of Joint: (Inlet, Discharge, Bypass)	
Duct I.S. or Diameter:	
Face To Face:	IN.
Operating:	°F
Design:	°F
Operating:	PSI
Design:	PSI
Axial Compression:	IN.
Axial Extension:	IN.

# Blowers & Compressors

For "Blower" and "Compressor" applications where expansion joints are required to absorb movements and vibration, please consider using the following rubber expansion joints manufactured by PROCO Products Inc. ...

- Series 240/242 Molded Expansion Joints
- Series RC Concentric Reducer Expansion Joints
- Series RE Eccentric Reducer Expansion Joints
- Series 251 Molded Wide-Arch Expansion Joints

PROCO recommends that EPDM and/or Chlorobutyl (Butyl) be used for blower and compressor service. Available inventories sizes range from 1" to 30".



**PROCO Series 240/242**  
Molded Expansion Joints  
for Blower Service



**PROCO Series RC/RE**  
Concentric/Eccentric Reducer Expansion Joints  
For Blower Service

**Engineering Note:** Non-Metallic flexible fan/duct connectors are critical to system performance. PROCO Products, Inc. encourages each specifying engineer and expansion joint user to become familiar with the F.S.A. Standards and to specify equipment designed in accordance with recommended practices. To obtain a copy of the F.S.A. Technical Handbook, write to the: Fluid Sealing Association • 2017 Walnut Street • Philadelphia, PA 19103

## Speed Is Our Strength!

- Same-day shipping
- Knowledgeable sales staff that has an average of 16 years experience with expansion joints
- Daily UPS® and ROADWAY® pick-up
- Preselected freight carriers to minimize "interline transfer"

- Emergency service for nights, weekends, and even holidays
- Complete expansion joint product line
- Largest inventory in North America



2431 North Wigwam Dr. (95205)  
P.O. Box 590 • Stockton, CA  
95201-0590 • USA



Same Day Shipment From Order Placement

DISTRIBUTED BY:

TOLL-FREE PHONE: (800) 344-3246 **NATIONWIDE AND CANADA**  
FACSIMILE: (209) 943-0242

**GOODYEAR**  
RUBBER PRODUCTS, INC.

727-342-5088

You can also email us at  
[GRP@goodyearrubberproducts.com](mailto:GRP@goodyearrubberproducts.com)

# PROCO



**RAIDED FLEXIBLE METAL CONNECTORS**

**GOODYEAR**  
RUBBER PRODUCTS, INC.

☎ 727-342-5088

You can also email us at  
[GRP@goodyearrubberproducts.com](mailto:GRP@goodyearrubberproducts.com)

# Braided Flexible Metal Pump Connectors

**PROCO** Products braided flexible metal pump connectors have been designed to control vibration, reduce noise, relieve stress, prevent system shock and compensate for misalignment and movement. Use of braided metal connectors for applications such as pumps, compressors, and other mechanical equipment will enhance the overall operation of the system.

Flexible metal hose by itself, when subjected to high pressure can over-extend past the ability to operate properly. It is necessary, therefore, to include an external flexible restraint (i.e., braid) to withstand the specified internal pressure and prevent excessive elongation. Braid, (woven metal) is designed to fit snugly over metal hose and is fastened to the ends of both hose and fittings. This braid is designed to be strong enough to withstand elongation for the full pressure rating of the hose.

Flexible metal hose and braid can be made from a variety of different metals to meet industry needs. Specification of the hose and braid is determined by temperature, pressure, flow media, application and external environment. Common materials used for braided flexible metal connectors are 321 stainless steel hose and a 304 stainless steel braid and are carried in stock by **PROCO** Products. The products contained in this catalog are representative of the typical sizes, lengths and materials found for pump connectors; however, other materials and lengths are available and can be ordered per customer specification.

## **PROCO "The Expansion Joint and Check Valve People"**

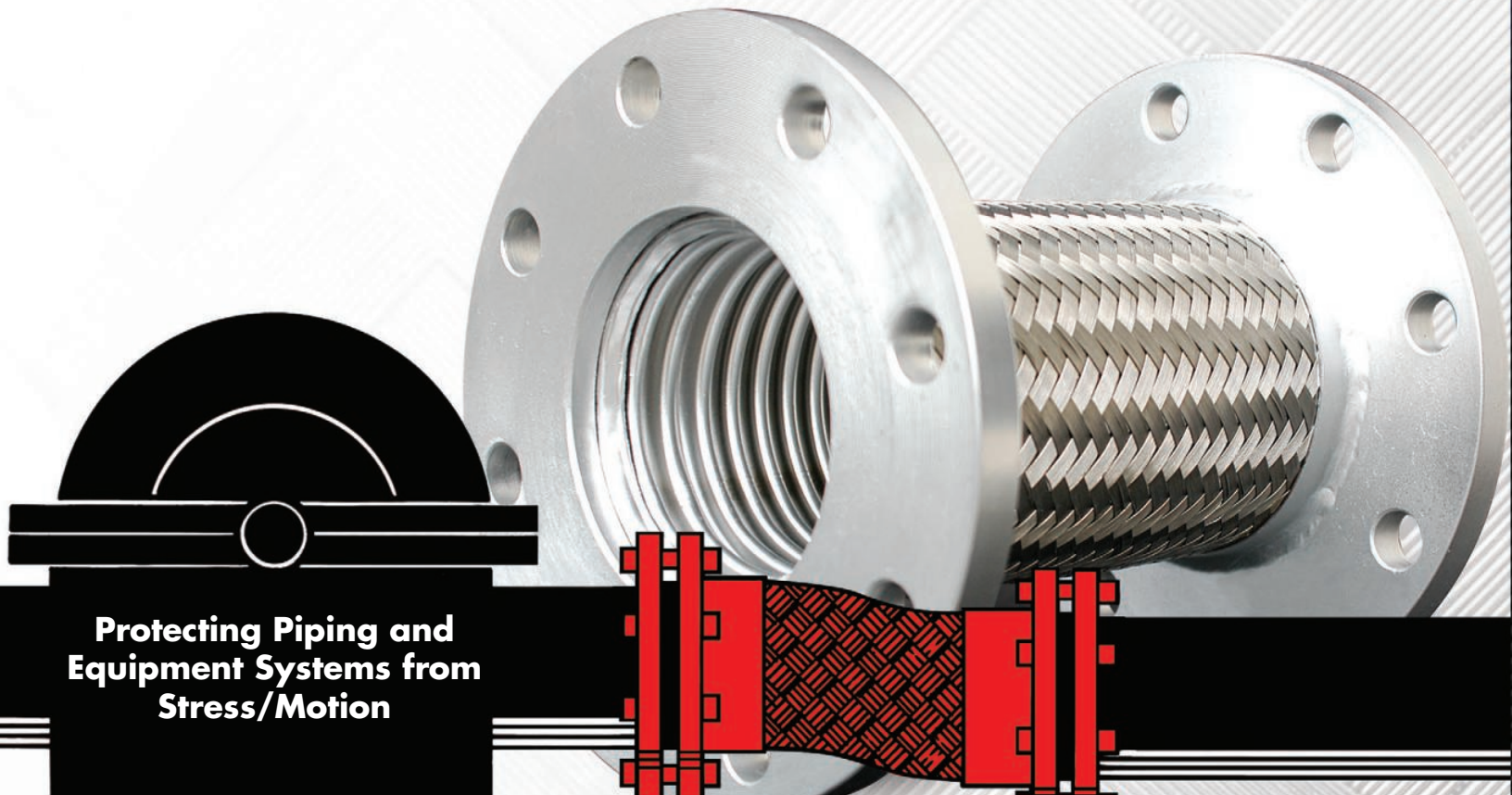
### **PROCO PRODUCTS, INC. IS HEADQUARTERED IN STOCKTON, CALIFORNIA**

Our 17,144 square foot warehouse houses one of the largest inventories of expansion joint products in North America.

**PROCO** is a major supplier of rubber expansion joints, PTFE expansion joints, rubber pipe vibration dampeners, low torque gaskets, threaded union rubber connectors, flexible metal pump connectors, and duck billed rubber check valves.

**PROCO** markets products to the power generation industry, refinery & chemical process industry, HVAC industry, pulp & paper industry, water & waste-water treatment industry and general industrial institutions **through a distribution network.**

*For a complete catalog of important products offered by **PROCO**, please contact the **Customer Service Department at 800-344-3246** (USA/Canada), **209-943-6088** (International) or use the attached specification sheet found on the back page of this catalog and fax your request to 209-943-0242.*



**Protecting Piping and  
Equipment Systems from  
Stress/Motion**

**GOODYEAR**  
RUBBER PRODUCTS, INC.

**727-342-5088**

You can also email us at  
[GRP@goodyearrubberproducts.com](mailto:GRP@goodyearrubberproducts.com)

# Largest Inventory

**PROCO** has one of the largest inventories in North America. Our customer service staff is ready to field your request.

## Emergencies Happen

When they do and you need one of **PROCO'S** various standard products, it is relieving to know we can respond with same day shipment from order placement.

So when you or your customer have an emergency request. . .

CALL **PROCO!** Day or night, **PROCO** will respond to your request and meet your urgent need.

## After Hours Service

**Call our 800 Number with your Urgent Request!**

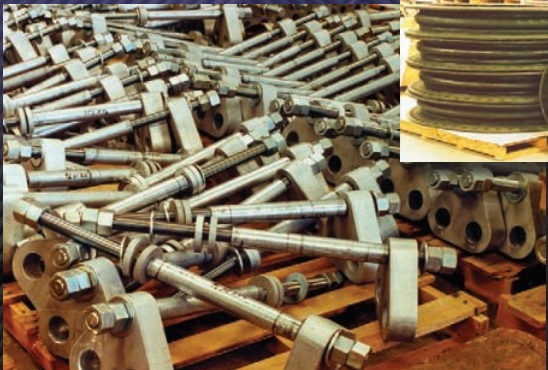
We will respond to meet your urgent need. There is no other phone number to remember.

# Expedite Shipping

**PROCO'S** Stocked Inventory can ship same day as order placement. . . .

Customer's can also count on consistent shipping costs due to our contracts with various well known carriers. Our shipment tracking system also gives customers assurance that their package is always accounted for.

**We can ship Standard Surface, 2nd or Next Day Air. In addition, our experience in export shipments is second to none.**

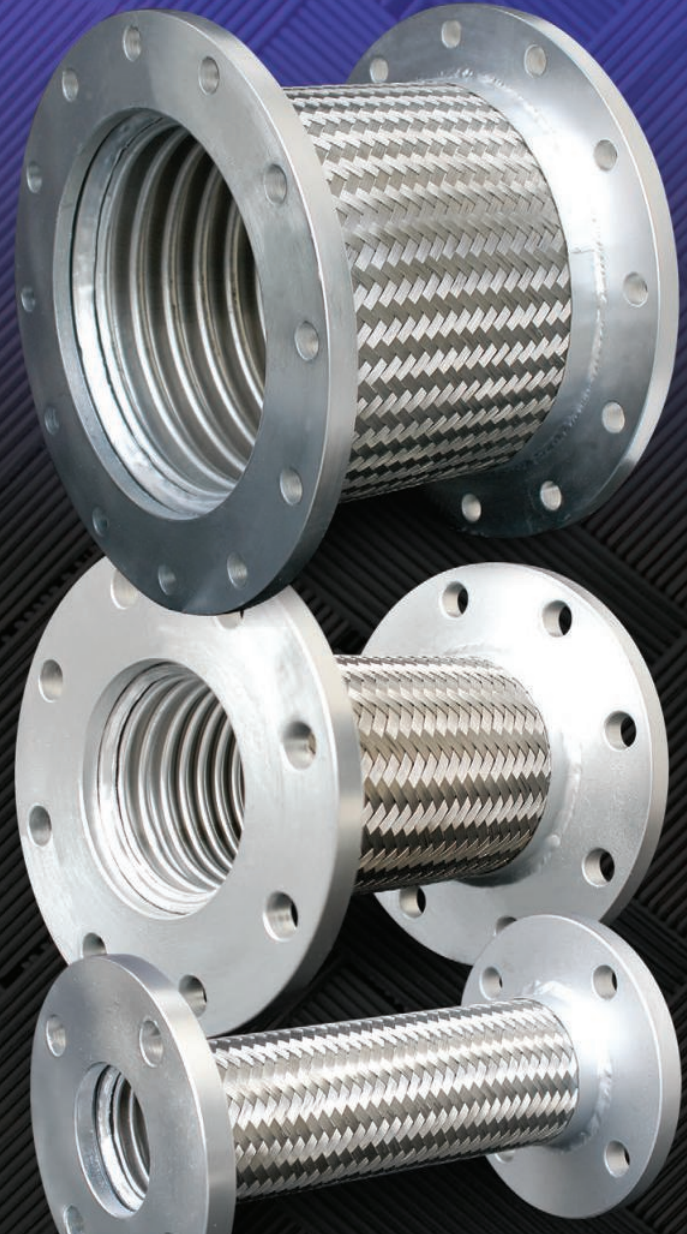
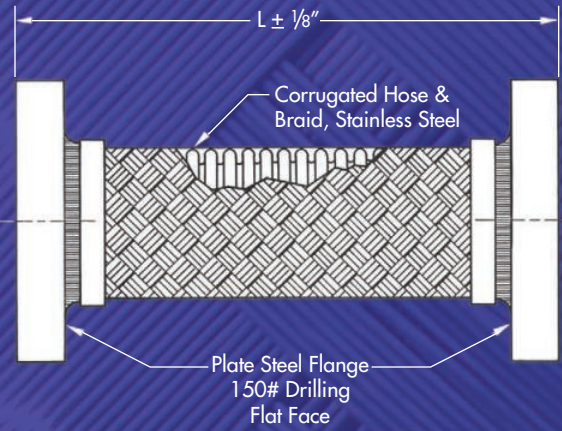


# SERIES FF - 6201

Braided Flexible Metal Flanged Connectors (321 Stainless Steel Hose with 304 Stainless Steel Braid and Carbon Steel Plate Flanges).

**Table 1: Sizes • Offset • Working Pressures • Weights**

Expansion Joint Size: ID X Length	Stock	Lateral Offset		Working Press (PSI)		Approx. Unit Ship Weight
		Inter-mittent	Perma-nent	@70 °F	@300 °F	
2 x 9	S	1/8"	3/8"	455	400	9
2 x 12	S	3/4"	1"	455	400	12
2 1/2 x 9	S	1/8"	3/8"	345	303	13
2 1/2 x 10	S	1/8"	3/8"	345	303	13
2 1/2 x 10 1/4	S	3/8"	3/4"	345	303	13
2 1/2 x 12	S	3/4"	1"	345	303	13
3 x 9	S	1/8"	3/8"	289	254	14
3 x 10	S	1/8"	3/8"	289	254	14
3 x 10 5/8	S	3/8"	3/4"	289	254	14
3 x 14	S	3/4"	1"	289	254	15
4 x 9	S	1/8"	3/8"	300	264	18
4 x 10	S	1/8"	3/8"	300	264	18
4 x 11 3/4	S	3/8"	3/4"	300	264	19
4 x 16	S	3/4"	1"	300	264	20
5 x 11	S	1/8"	3/8"	220	193	25
5 x 12	S	1/8"	3/8"	220	193	25
5 x 13 5/8	S	3/8"	3/4"	220	193	27
5 x 18	S	3/4"	1"	220	193	30
6 x 11	S	1/8"	3/8"	200	176	28
6 x 12	S	1/8"	3/8"	200	176	28
6 x 14 1/8	S	3/8"	3/4"	200	176	30
6 x 20	S	3/4"	1"	200	176	34
8 x 12	S	1/8"	3/8"	190	167	52
8 x 13	S	1/8"	3/8"	190	167	52
8 x 15 3/8	S	3/8"	3/4"	190	167	64
8 x 22	S	3/4"	1"	190	167	65
10 x 13	S	1/8"	3/8"	165	145	65
10 x 14	S	1/8"	3/8"	165	145	65
10 x 17 3/4	S	3/8"	3/4"	165	145	68
10 x 24	S	3/4"	1"	165	145	75
12 x 14	S	1/8"	3/8"	125	110	105
12 x 15	S	1/8"	3/8"	125	110	105
12 x 18 3/8	S	3/8"	3/4"	125	110	110
12 x 26	S	3/4"	1"	125	110	113
14 x 14	S	1/8"	3/8"	105	92	115
14 x 15	S	1/8"	3/8"	105	92	115
14 x 20	X	3/8"	3/4"	105	92	119
14 x 28	X	3/4"	1"	105	92	126



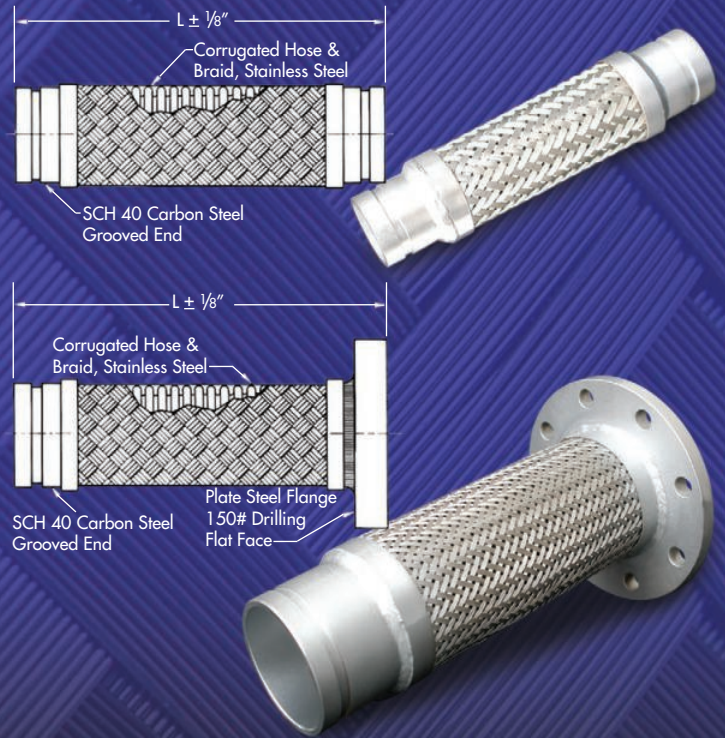
# SERIES GG - 6201 or SERIES GF - 6201

Braided Flexible Metal Grooved Connectors (321 Stainless Steel Hose with 304 Stainless Braid and Grooved Ends or Grooved by Flange Ends).

**Table 2: Sizes • Offset • Working Pressures • Weights**

Expansion Joint Size: ID X Length	Stock	Lateral Offset		Working Press (PSI)		Approx. Unit Ship Weight
		Inter-mittent	Perma-nent	@70 °F	@300 °F	
2 x 12	S	1/8"	3/8"	450	396	10
2 1/2 x 14	S	1/8"	3/8"	345	303	12
3 x 14	S	1/8"	3/8"	289	254	13
4 x 16	S	1/8"	3/8"	300	264	18
5 x 17	S	1/8"	3/8"	220	193	25
6 x 18	S	1/8"	3/8"	200	176	28
8 x 20	S	1/8"	3/8"	190	167	50
10 x 24	S	1/8"	3/8"	150	132	70
12 x 25	S	1/8"	3/8"	125	110	90

NOTES: 1. Also comes in Grooved by Flange Design. Please specify series GF-6201  
 2. Weight based on Series GF-6201  
 3. "S" indicates stocked item.

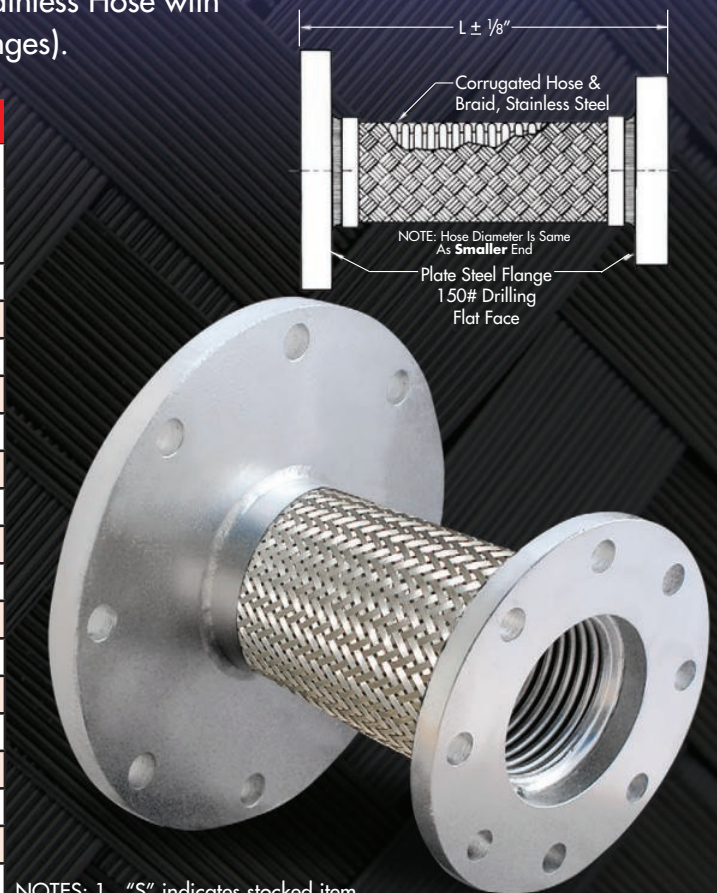


# SERIES R - 6201

Braided Flexible Metal Reducing Connectors (321 Stainless Hose with 304 Stainless Steel Braid and Carbon Steel Plate Flanges).

**Table 3: Sizes • Offset • Working Pressures • Weights**

Expansion Joint Size: ID X Length	Stock	Lateral Offset		Working Press (PSI)		Approx. Unit Ship Weight
		Inter-mittent	Perma-nent	@70 °F	@300 °F	
3 x 2 x 9	S	1/8"	3/8"	345	303	14
4 x 2 x 9	S	1/8"	3/8"	455	400	14
4 x 3 x 9	S	1/8"	3/8"	289	254	16
5 x 3 x 9	S	1/8"	3/8"	289	254	22
5 x 4 x 9	S	1/8"	3/8"	300	264	25
6 x 3 x 9	S	1/8"	3/8"	289	254	23
6 x 4 x 9	S	1/8"	3/8"	300	264	30
6 x 5 x 11	S	1/8"	3/8"	220	193	35
8 x 4 x 9	S	1/8"	3/8"	300	264	58
8 x 5 x 11	S	1/8"	3/8"	220	193	58
8 x 6 x 11	S	1/8"	3/8"	200	176	61
10 x 6 x 11	S	1/8"	3/8"	200	176	80
10 x 8 x 12	S	1/8"	3/8"	190	167	85
12 x 8 x 12	S	1/8"	3/8"	190	167	105
12 x 10 x 13	S	1/8"	3/8"	150	132	135
14 x 10 x 13	X	1/8"	3/8"	120	105	140
14 x 12 x 14	X	1/8"	3/8"	100	88	145



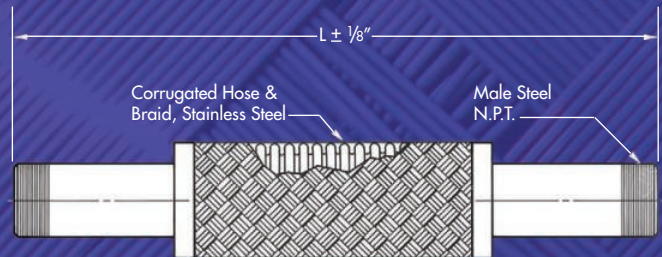
NOTES: 1. "S" indicates stocked item.  
 2. "X" denoted 1-2 week shipment lead time.

# SERIES TTS - 6201

Braided Flexible Metal Threaded Connectors (321 Stainless Steel Hose with 304 Stainless Steel Braid and Male Carbon Steel Ends (NPT).

**Table 4: Sizes • Offset • Working Pressures • Weights**

Expansion Joint Size: ID X Length	Stock	Lateral Offset		Working Press (PSI)		Approx. Unit Ship Weight
		Intermittent	Permanent	@ 70 °F	@ 300 °F	
1/2 x 6 1/2	S	1/4"	1/2"	1300	1144	1
1/2 x 9	S	1/4"	1/2"	1300	1144	1
1/2 x 10	S	1/4"	1/2"	1300	1144	1
3/4 x 7	S	1/4"	1/2"	880	774	1
3/4 x 10	S	1/4"	1/2"	880	774	1
3/4 x 11	S	1/4"	1/2"	880	774	1
1 x 8	S	1/4"	1/2"	605	532	1
1 x 10	S	1/4"	1/2"	605	532	1
1 1/4 x 8 1/2	S	1/4"	1/2"	605	532	1
1 1/4 x 10	S	1/4"	1/2"	570	501	1 1/2
1 1/4 x 11	S	1/4"	1/2"	570	501	1 1/2
1 1/4 x 12	S	1/4"	1/2"	570	501	2
1 1/4 x 13	S	1/4"	1/2"	570	501	2
1 1/2 x 9	S	1/4"	1/2"	570	501	1 1/2
1 1/2 x 12	S	1/4"	1/2"	525	462	1 1/2
1 1/2 x 14	S	1/4"	1/2"	525	462	2
2 x 10 1/2	S	1/4"	1/2"	455	400	2
2 x 12	S	1/4"	1/2"	455	400	2 1/2
2 x 14	S	1/4"	1/2"	455	400	3
2 x 15	S	1/4"	1/2"	455	400	3
2 1/2 x 12	S	1/4"	1/2"	345	303	5
2 1/2 x 14	S	1/4"	1/2"	345	303	5 1/2
2 1/2 x 16	S	1/4"	1/2"	345	303	6
3 x 14	S	1/4"	1/2"	290	255	8
3 x 16	S	1/4"	1/2"	290	255	9
3 x 17	S	1/4"	1/2"	290	255	10



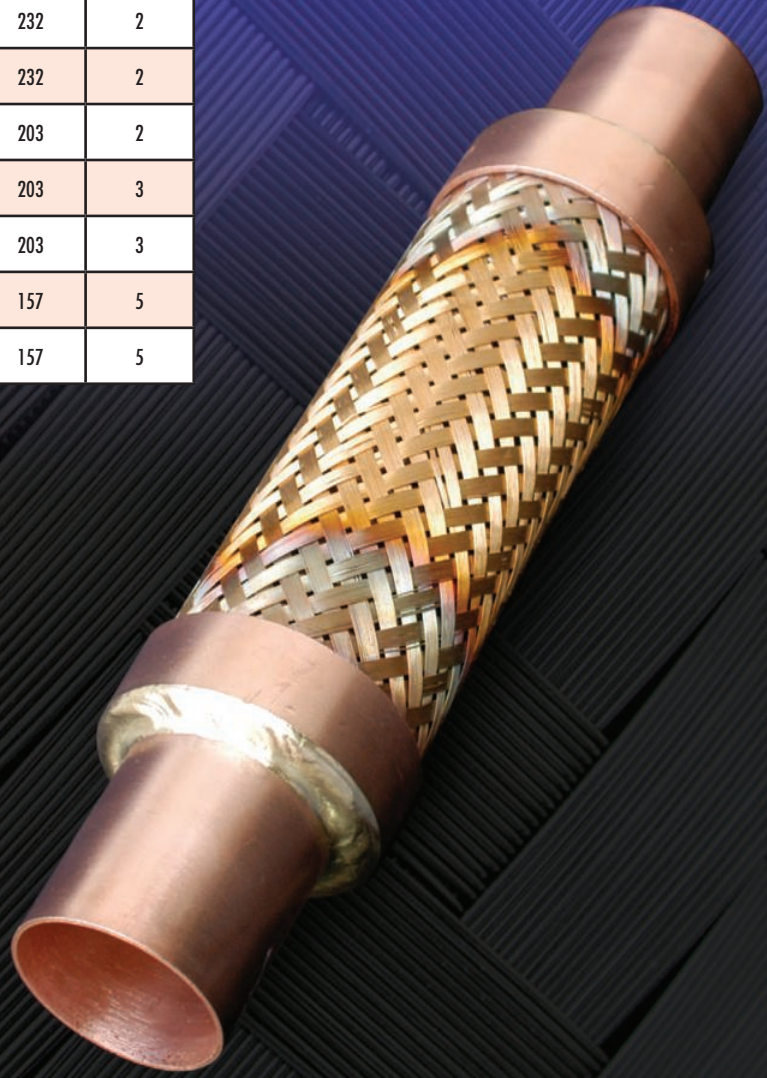
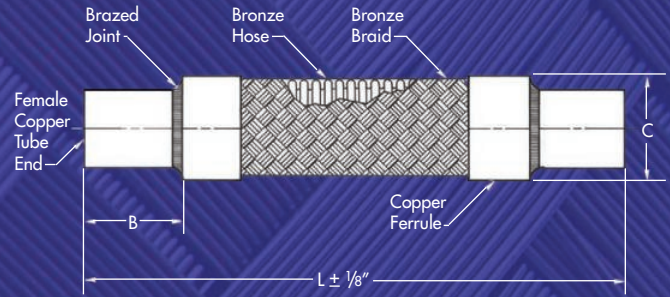
NOTES: 1. "S" indicates stocked item.  
2. "X" denotes 1-2 week shipment lead time.

# SERIES SEB - 6201

Braided Flexible Metal Sweat Connectors (Bronze Hose with Bronze Braid and Copper Female Ends).

**Table 6: Sizes • Offset • Working Pressures • Weights**

Expansion Joint Size: ID X Length	Stock	Lateral	Working Press (PSI)		Approx. Unit Ship Weight
		Offset Permanent	@ 70 °F	@ 300 °F	
1/2 x 10	S	1"	450	374	1
1/2 x 11	S	1"	450	374	1
3/4 x 10	S	3/4"	340	282	1
3/4 x 11	S	3/4"	340	282	1
1 x 10	S	1/2"	302	250	1
1 x 12	S	1/2"	302	250	1 1/2
1 1/4 x 10	S	3/8"	280	232	2
1 1/4 x 11	S	3/8"	280	232	2
1 1/4 x 13	S	3/8"	245	203	2
1 1/2 x 12	S	3/8"	245	203	3
1 1/2 x 14	S	3/8"	245 </td <td>203</td> <td>3</td>	203	3
2 x 14	S	3/8"	190	157	5
2 x 15	X	3/8"	190	157	5



NOTES: 1. "S" indicates stocked item.  
2. "X" denotes 1-2 week shipment lead time.

# Temperature

Temperature correction factors and maximum material temperature ranges for braided flexible metal pipe connectors.

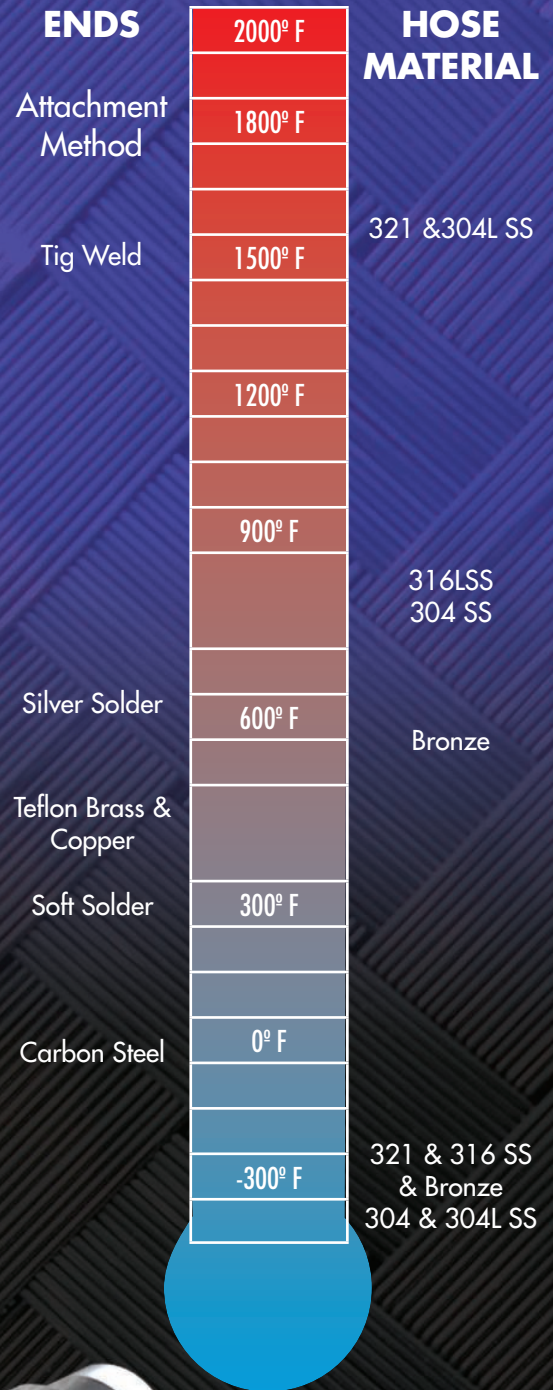
Temp °F	Material		
	Bronze	304 SS	321 SS
Ambient	1.00	1.00	1.00
150	.92	.96	.97
200	.89	.92	.94
250	.85	.91	.92
300	.83	.86	.88
350	.81	.85	.86
400	.78	.82	.83
450	.75	.80	.81
500		.77	.78
600		.73	.74
700		.69	.70
800		.64	.66
900		.58	.62
1000			.60
1100			.58
1200			.55
1300			.50
1400			.44
1500			.40

## Temperature Correction Factors

1. Determine maximum operating temperature.
2. Locate appropriate correction factor above.
3. Multiply maximum working pressure by correction factor at temperature for acceptable rating.

Service temperature for a braided flexible metal pump connector has a negative affect on the amount of maximum pressure to which it can be subjected. The table above should be used to calculate the safe working pressure based on the elevated temperature the braided metal pump connector is operating under. (Working Pressure X Elevated Temperature Conversion Figure = Safe Working Pressure.)

Contact **PROCO'S** sales office at **1-800-344-3246** (**209 943-6088 outside USA/Canada**) if help is needed with using the temperature correction chart.



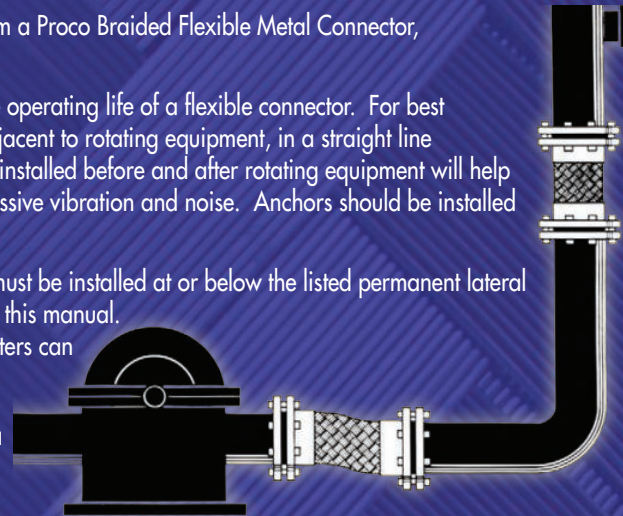
# Installation Instructions

To obtain maximum service life from a Proco Braided Flexible Metal Connector, please consider the following:

Proper placement is essential to the operating life of a flexible connector. For best results place flexible connectors adjacent to rotating equipment, in a straight line without offset. Flexible connectors installed before and after rotating equipment will help isolate the piping system from excessive vibration and noise. Anchors should be installed immediately beyond the connector.

Braided flexible metal connectors must be installed at or below the listed permanent lateral offset values listed on pages 3-6 of this manual. Failure to stay within these parameters can reduce the operating life of the flexible connector.

Figure 1



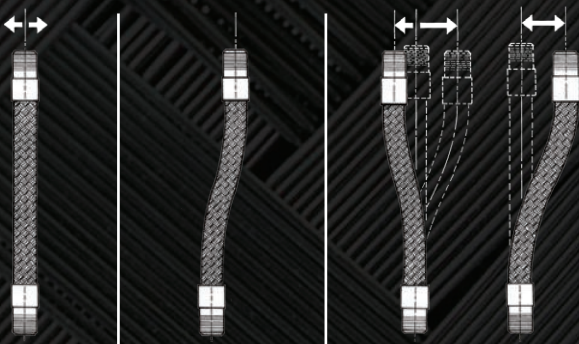
For lateral movements greater than those listed in tables on pages 3-6, it is possible to install two flexible connectors in a pipe system to achieve greater flexibility. Install two connectors at right angles to one another and between two anchor points. This scheme will allow for increased lateral offset capabilities. (See Figure 1.)

**Flanged Flexible Connectors** Flange alignment should be in accordance with industry standards. Bolt holes should be aligned so that braided flexible metal connectors are free of torsional movements, reduced operating life or failure will occur.

**Threaded Flexible Connector** Install one end of threaded connector to loose union and tighten. Install opposite threaded end of flexible connector to threaded pipe fitting and tighten. When installing union end to adjacent pipe fitting, it is important not to introduce torque to the braided flexible metal connector. If the flexible connector is subjected to torsional movements, reduced operating life or failure will occur.

**Sweat End Flexible Connector** Install female ends of the flexible connector to adjacent male ends of pipe in such a manner to eliminate any torque that may be imposed during fit-up.

## Types Of Offset Motion



**Vibration**

**Permanent Misalignment**

**Intermittent Movement**

**VIBRATION** Install in a straight line with a rigid support on the fixed end.

**MISALIGNMENT - (PERMANENT MISALIGNMENT)** Allow sufficient length to make a gradual bend.

**INTERMITTENT MOVEMENT** Refer to charts on pages 3-6 for maximum movement capabilities. Where offset movement occurs on both sides of the pipe centerline, the braided flexible hose live length should be based on the total stroke. For movement greater than those stated in this manual, it is suggested that a traveling loop system be used.



# Corrosion Evaluation Reference Table

The information contained herein this table is to be used as a guide for the selection of braided metal pump connector materials (i.e. hose and braid) suitable for chemicals listed below. This data should not be construed as advice to use or not use. Ultimate responsibility lies with the system designer or operator for correct material selection based on flow media. It is suggested that flow media be listed on the "Connector Specification Data Sheet", found on the back of this manual when requesting a quotation.

Corrosion Rate:



- A - RESISTANT ••••• less than .00035 inch penetration per month.
- B - PARTIALLY RESISTANT ••••• .00035 inch penetration per month.
- C - NON RESISTANT ••••• greater than .0035 inch penetration per month.

Chemical	Temp. °F.	304, 321 S.S.	Carbon Steel	Bronze	Chemical	Temp. °F.	304, 321 S.S.	Carbon Steel	Bronze	Chemical	Temp. °F.	304, 321 S.S.	Carbon Steel	Bronze
Acetic Acid 5%, 20% Agitated or Aerated	70°	A	C	C	Ammonium Sulphate					Citric Acid, 5% Still	70° - 150°	A	C	A
50%	70°	A	C	C	1% Aerated or Agitated	70°	A	C	C	15% Still	70°	A	C	B
50% - 80%	Boiling	C	C	C	5% Aerated & Agitated	70°	A	C	C	15% or Concentrated	Boiling	B	C	B
80%	70°	A	C	C	10% & Saturated	Boiling	B <sup>4</sup>	C	C	Coffee RSC	Boiling	A	C	A
100%	70°	A	C	C	Ammonium Sulphate, 70% Boiling	70°	A	C	C	Copper Acetate (Saturated Solution)	70°	A	C	
100%	Boiling	C	C	C	Barium Carbonate	70°	A	B	A	Copper Carbonate (Sat. Sol.) in 50% NH <sub>4</sub> OH		A		C
100% - 150 lbs. Pressure	400°	C	C	C	Barium Chloride 5% & Saturated	70°	A <sup>3,4</sup>	C	B	Copper Chloride,				
Acetic Acid Vapors, 30%	Hot	C	C	C	Barium Hydroxide Aqueous Solution	Hot	A	B	A	1% Agitated	70°	B <sup>3,4</sup>	C	C
100%	Hot	C	C	C	Barium Nitrate Aqueous Solution	Hot	A	B		1% Aerated	70°	B <sup>3,4</sup>	C	C
Acetyl Chloride	Cold	B <sup>3</sup>	C	B	Barium Sulphate	70°	A		A	5% Agitated	70°	C	C	C
	Boiling	B <sup>3</sup>	C	B	Barium Sulphide Saturated Solution	70°	A	C	C	5% Aerated	70°	C	C	C
Acetylene Concentrated	70°	A	A	C <sup>2</sup>	Beer (Barley, Malt & Hops)	70°	A	C	A	Copper Cyanide (Saturated Solution)	Boiling	A	C	C
Commercially Pure	70°	A	A	C <sup>2</sup>	3.5% - 4.5% Alcohol	160°	A	C	A	Copper Nitrate				
Acid Salt Mixture					Benzene (Benzol) 70° or Hot	70°	A	B	A	1% Still, Agitated & Aerated	70°	A	C	C
10% H <sub>2</sub> SO <sub>4</sub> Sp. G. 1.07 + 10% CuSO <sub>4</sub> • 5 H <sub>2</sub> O	Boiling	A <sup>3,4</sup>	C	C	Benzoic Acid	70°	A	A	A	5% Still, Agitated & Aerated	70°	A	C	C
Acid Salt Mixture					Borax 5%	Hot	A	B	A	50% Aqueous Solution	Hot	A	C	C
10% H <sub>2</sub> SO <sub>4</sub> Sp. G. 1.07 + 2% FeSO <sub>4</sub> • 7 H <sub>2</sub> O	Boiling	A <sup>3,4</sup>	C	C	Boric Acid					Copper Sulphate				
Alcohol, Ethyl, 70° & Boiling	70°	A	A	A	5% Solution, 70° or Hot	70°	A	C	A	5% Agitated Still or Aerated	70°	A	C	B
Alcohol, Methyl	70°	A	A	A	5% Solution	Boiling	A	C	A	Saturated Solution	Boiling	A	C	B
	Boiling	C	C	A	Saturated Solution	70°	A <sup>3,4</sup>	C	B	Creosote (Coal Tar)	Hot	A	B	A
Aluminum Acetate, Saturated	70°	A	C	C	Saturated Solution	Boiling	A <sup>3,4</sup>	C	C	Creosote Oil	Hot	A	B	B
	Boiling	A	C	C	Bromine Water	70°	C	C	C	Dichloroethane (Dry)	Boiling	A	C	C
Aluminum Chloride					Butyl Acetate		A	B		Dyewood Liquor	70°	A <sup>1</sup>	C	
10% Quiescent	70°	C	C	C	Calcium Chloride Dilute or Concen. Solution	70°	B <sup>3,4</sup>	C	B	Epsom Salt (Magnesium Sulphate)	Hot & Cold	A <sup>3,4</sup>	C	A
25% Quiescent	70°	A <sup>3,4</sup>	C	C	Calcium Chlorohypochlorite					Ethyl Acetate (Concentrated Solution)	70°	A	B	A
Aluminum Fluoride	70°	C	C	C	(Bleaching Powder) 1%	70°	C	C	B	Ethyl Chloride	70°	A <sup>3,4</sup>	B	B
Aluminum Hydroxide, Saturated	70°	A	A <sup>4</sup>	A	(Bleaching Powder) 5%	70°	C	C	B	Ethylene Chloride	70°	A <sup>3,4</sup>	B	B
Aluminum Sulphate, 5%	150°	A	C	C	Calcium Hypochlorite, 2%	70°	B <sup>4</sup>	C	B	Ethylene Glycol	70°	A	B	A
10%	70°	A	C	C	Calcium Hydroxide, 10-20%	Boiling	A	C	A	Ferric Chloride				
10%	Boiling	B	C	C	Calcium Sulphate, Saturated	70°	A	C	A	1% Solution Still	70°	B <sup>3,4</sup>	C	C
Saturated	70°	A	C	C	Carbonic Acid Saturated Solution	70°	A	C	A	1% Solution	Boiling	C	C	C
Saturated	Boiling	B	C	C	Carbolic Acid	70°	A	C	B	5% Solution, Agitated, Aerated	70°	C	C	C
Aluminum Potassium Sulphate:					Carbolic Acid	Boiling	A	C	B	Ferric Hydroxide		A	C	
(Alum) 2%-10%	70°	A	C	B	Carbon Bisulfide	70°	A	B	B	Ferric Nitrate				
10%	Boiling	B	C	C	Carbon Monoxide Gas	1400°	A	A	C	1-5% Quiescent or Agitated	70°	A	C	C
Saturated	Boiling	C	C	C	Carbon Monoxide Gas	1600°	A	A	C	1-5% Aerated	70°	A	C	C
Ammonia (Anhydrous):					Carbon Tetrachloride					Ferric Sulphate				
All Concentrations	70°	A	A	A	Commercially Pure	70°	A <sup>3,4</sup>	B	A	1-5% Quiescent or Agitated	70°	A <sup>4</sup>	C	C
Gas	Hot	C	C	C	Dry Commercially Pure	Boiling	A <sup>3,4</sup>	B	A	1-5% Aerated	70°	A <sup>4</sup>	C	C
Ammonia Liquor	70°	A	C	C	Commercial + 1% Water		C	C	B	10%	Boiling	A <sup>4</sup>	C	C
	Boiling	A	C	C	Chloracetic Acid	70°	C	C	B	Ferrous Chloride: Saturated Solution	70°	C	C	B
Ammonium Bicarbonate	70°	A	C	C	Chlorbenzol Concentrate Pure Dry	70°	A	B	B	Ferrous Sulphate: Dilute Solution	70°	A	C	B
	Hot	A	C	C	Chloric Acid	70°	C	C	C	Fluorine (Gas) Moist	70°	C	C	C
Ammonium Bromide	70°	B	C	C	Chlorine Gas (Dry)	70°	C	B	A	Formaldehyde 40% Solution		A <sup>4</sup>	B	A
Ammonium Carbonate 1% & 5%	70°	A	A	C	(Moist)	70°	C	C	C	Formic Acid, 5% Still	70°	B	C	B
Ammonium Chloride 1%	70°	A <sup>3,4</sup>	B	C	Chlorinated Water, Saturated		C	C <sup>4</sup>		5% Still	150°	B	C	B
10%	Boiling	A <sup>3,4</sup>	C	C	Chloroform	70°	A	A	A	Fuel Oil	Hot	A	B	A
28%	Boiling	B <sup>3,4</sup>	C	C	Chromic Acid					Containing Sulphuric Acid		C	C	C
50%	Boiling	B <sup>3,4</sup>	C	C	5% Commercially Pure	70°	A	C	C	Gallic Acid, 5%	70°-150°	A	C	
Ammonium Hydroxide: All Concentrations	70°	A	B	C	10%	70°	C	C	C	Saturated	212°	A	C	
Ammonium Monophosphate	70°	A	B	C	Chromic Acid					Gasoline	70°	A	B	A
Ammonium Nitrate:					10% Commercially Pure	Boiling	C	C	C	Hydrochloric Acid: All Concentrations	70°	C	C	C
All Concentrate Agitated	70°	A	C	C <sup>2</sup>	50% Commercially Pure	70°	C	C	C	Hydrocyanic Acid	70°	A	C	C
All Concentrate Aerated	70°	A	C	C <sup>2</sup>	50% Commercially Pure	Boiling	C	C	C	Hydrofluoric Acid	70°	C	C	C
All Concentrate Saturated	Boiling	A	C	C <sup>2</sup>	Commercial 50% (Cont. SO <sub>3</sub> )	70°	C	C	C	Hydrofluosilic Acid	70°	C	C	B
Ammonium Perchlorate 10%	Boiling	A <sup>3,4</sup>	B	C	Commercial 50% (Cont. SO <sub>3</sub> )	Boiling	C	C	C	Hydrogen Sulphide (Dry)	70°	A	B	A



# Order Form

Fax: 209.943-0242 or Email: sales@procoproducts.com

## Series 6201 Braided Flexible Metal Pump Connector Specification Data Sheet

Customer Name:	Date:	Page:	
Address:	City:	ST.	Zip:
Phone:	Fax:		

### PROCO - Your Expansion Joint Source!

Inquiry / Job #

Design Data		TAG #	TAG #	TAG #
Quantity Required				
Nominal Diameter (Inches)				
Overall Length Required				
Hose Material Type: (321 S/S, BRZ) Or _____				
End Fittings	End Type (FF, GF, GG, TT, SEB) Or _____			
	Material Type (C/S, Copper) Or _____			
Maximum Continuous System Operating Temperature (MCSOT)				
Pressure/Vacuum (see conversion chart page 7)	Working Pressure @ _____ °F			
	Working Pressure @ _____ °F			
System Application / Location				
Flow Media / Environment				
Movement Conditions	Misalignment (List Value)			
	Intermittent	Lateral Y or N	in.	in.
	Movement	Angular Y or N	Degree	Degree
	Vibration	Y or N		

**Attention:** (Circle One) Sylvia Augusto • Steve Bowman • Stacie Cummings • Richard Garcia  
Gary Haxby • Kim Kimball • Ivan Martinez

For direct contact with a Customer Service Representative, please call **1-800-344-3246**  
USA / Canada. Outside USA / Canada, please call **209-943-6088**



2431 North Wigwam Dr. (95205)  
P.O. Box 590 • Stockton, CA  
95201-0590 • USA

Toll-Free Phone: (800) 344-3246 **NATIONWIDE AND CANADA**

Facsimile: (209) 943-0242

(209) 943-6088 **INTERNATIONAL**



REPRESENTED BY:



727-342-5088

You can also email us at  
GRP@goodyearrubberproducts.com

# PROCO

*The Expansion Joint and Check Valve People*



**PROFLEX™ RUBBER CHECK VALVES SERIES 700**

**GOODYEAR**  
RUBBER PRODUCTS, INC.

☎ 727-342-5088

You can also email us at  
[GRP@goodyearrubberproducts.com](mailto:GRP@goodyearrubberproducts.com)

# PROCO SERIES 700

The PROCO Series 700 ProFlex™ Rubber Check Valves are a cost effective way to control back pressures from sewage treatment plants, outfalls and tidal operations. They are a fully passive flow device requiring neither maintenance nor any outside sources of power or manual assistance to operate.

The PROCO Series 700 ProFlex™ Check valves are offered as direct replacements for ineffective and maintenance ridden flap type check valves, commonly known to seize, rust and bind in unwanted positions. Unlike flap type valves, the ProFlex™ rubber check valves will handle large obstructions without jamming or having swing gates binding open. Specify the PROCO Series 700 ProFlex™ rubber check valves to provide backflow protection from (1) Sewage slurries, (2) Outfalls to ocean fronts from heavy rainfall activity, (3) Prevention from land erosion due to back flow conditions, (4) Protection from saltwater to fresh water ponds and catch basins and numerous other water based applications. Our history in the manufacture of rubber piping products dates back to 1930. When an engineered solution is needed to solve a piping or backflow problem, call PROCO.

The PROCO Series 700 ProFlex™ Rubber Check valves are available in a Flanged (Style 710 or 720), Sleeved (Style 730 or 740), Jacketed (Style 750). Inline orifice (style 770/780), or low headloss in-line (Style 790)

- **Style 710: Flanged:** Designed to bolt directly to existing flanges or new installations, flanges are drilled to ANSI 125/150# standard. Other drilling standards are also available upon request. The style 710 can be installed in either vertical or horizontal applications.
- **Style 711/731 Flanged/Slip-on Slope Bottom Check Valves:** Designed for installation on pre-existing or new pipe lines such as manholes, outfalls, vaults, where the outfall invert of the pipe is close to the floor of the manhole or outfall. Can be engineered into the pipe layout with little concern for outfall clearance due to its "low slope" design.
- **Style 720: Flanged In-line:** Designed to fit directly inside of an existing pipe. Supplied with a flat face rubber flange which allows installation between existing pipe flanges eliminating the requirement for a valve body. Flanges are drilled to ANSI 125/150# standard. Other drilling standards are also available upon request.

- **Style 730: Sleeve Type:** Designed to easily slip over an existing pipe, and is affixed with heavy-duty stainless steel clamps. Can be installed in either a vertical or horizontal application.
- **Style 740: Slip In-Inline:** Designed to slip directly inside of an existing pipe. Supplied with a stainless steel expandable clamp to secure it in place.
- **Style 750: Jacketed:** Designed with a full metal enclosure which allows easy installation in existing piping systems. Utilizes the Style 710 as the check valve.
- **Style 770/780: Wafer Style:** Designed with a metal or plastic orifice plate and a rubber disk, this valve is an ideal valve to provide high back pressure capability on clean water applications.
- **Style 790: Low Headloss In-Line:** Designed as an all one piece constructed valve, the Style 790 is one of lowest headloss valves on the market. A passive flow device insuring no delamination.

**ELASTOMERS:** All of the PROCO Series 700 ProFlex™ Rubber Check Valves are available in a various selection of elastomers including NSF61/ANSI 6. Product certified under UL20160711-MH47689.

The PROCO Series 700 ProFlex™ Rubber Check Valves will not freeze or deform and function solely on the inlet and back pressures which will be present in each application. Each valve is carefully constructed using the finest of engineered materials and some of the most experienced rubber technicians in the industry. All check valves are engineered in precise detail to ensure proper operation and will provide years of unhindered operation and trouble free service.

#### Benefits of the PROCO Series 700 ProFlex™ Rubber Check Valves:

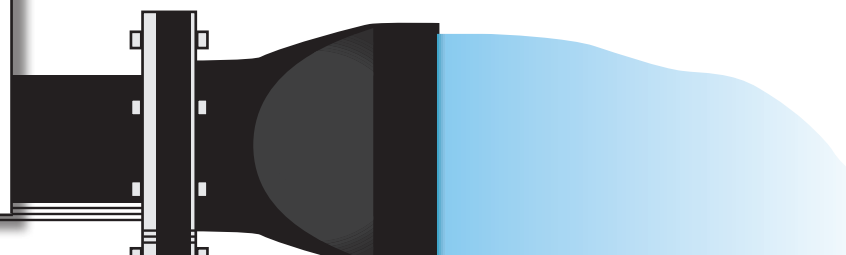
- All rubber construction resists abrasive slurries
- Barnacle resistant Neoprene is standard construction, with NSF61 valves also available.
- Very quiet operation with no water hammer
- Its unique design prevents backflow
- Negligible maintenance and energy costs
- Will not warp or freeze
- Quick interchange with any flap type check valve
- Available in sizes 1"– 96"
- Available with special I.D to suit concrete pipe.

**Table 1: Available Materials • Temperatures**

For Specific Elastomer Recommendations, See: PROCO™ "Chemical To Elastomer Guide"

PROCO Material Codes	Cover 1, 2 Elastomer	Tube Elastomer	Maximum Operating Temp. °F (°C)	F.S.A. Material Class
BB	Chlorobutyl	Chlorobutyl	250° (121°)	STD. III
EE	EPDM	EPDM	250° (121°)	STD. III
NH	Neoprene	CSM	212° (100°)	STD. II
NN	Neoprene	Neoprene	225° (107°)	STD. II
NN-NSF61 <sup>3</sup>	Neoprene	Neoprene	225° (107°)	STD. II
PP	Nitrile	Nitrile <sup>3</sup>	225° (107°)	STD. II
NR	Neoprene	Natural Rubber	180° (82°)	STD. I

Notes: ProFlex™ is a trademark of PROCO Products, Inc.



Proco  
Style **710**  
**ProFlex™ Flanged  
Rubber Check Valves**



Proco  
Style **711**  
**ProFlex™ Flanged  
Slope Bottom Check Valves**  
*Covered by US Patent Number 11,221,081*

Proco  
Style **730**  
**ProFlex™ Slip-on  
Rubber Check Valves**



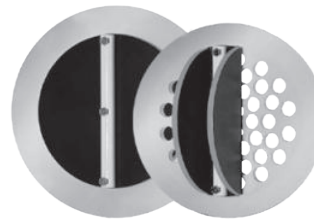
Proco  
Style **731**  
**ProFlex™ Slip-on Slope  
Bottom Check Valves**  
*Covered by US Patent Number 11,221,081*

Proco  
Style **720**  
**ProFlex™ In-line  
Flanged Rubber  
Check Valves**



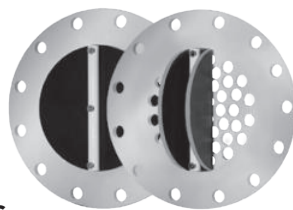
Proco  
Style **740**  
**ProFlex™ Slip-in Style  
In-line Rubber Check  
Valves**

Proco  
Style **750**  
**ProFlex™ Jacketed  
In-line Flanged  
Rubber Check Valves**



Proco  
Style **770**  
**ProFlex™ Wafer  
Style In-line Rubber  
Check Valves**

Proco  
Style **780**  
**ProFlex™ Wafer  
Style In-line Flanged  
Rubber Check Valves**



Proco  
Style **790**  
**ProFlex™ Low  
Headloss In-line  
Rubber Check Valves**

# PROCO STYLE 710

## ProFlex™ Flanged Rubber Check Valves



The **ProFlex™ 710** is a full port, concentric design Rubber Duckbill Check Valve. The ProFlex™ 710 Rubber Duckbill Check Valves can be supplied with many different flange drilling configurations, including square or rectangular flanges to suit problematic sluice gate or flap gate replacements.

The unique advantage to this valve is its very low 1" - 2" (25mm-50mm) cracking pressure and is often referred to as the lowest head loss valve in the industry.

All **ProFlex™ 710** Rubber Duckbill Check Valves are supplied with 316ss retaining rings and can also be supplied with 304ss, Galvanized, Epoxy coated or FRP material if required.

The **ProFlex™ 710** Rubber Duckbill Check Valves come standard with ANSI 125/150 flange drilling and can also be supplied with DIN, JIS, BS or AS flange patterns.

All **ProFlex™ 710** Rubber Duckbill Check Valves are also available from inventory in a Standard Rated (SR) design up to 24in (600mm), and can also be custom manufactured to meet specific head and back pressures.

For higher pressure/vacuum requirements, the **ProFlex™ 710** Rubber Duckbill Check Valves can also be manufactured using a unique Internal Vacuum Supports (IVS) design which is homogeneous to the inner reinforced layers of the valve allowing a full flow with no obstructions and yet providing excellent anti-inversion features.

**Table 2: Sizes • Flange Drilling • Weights**

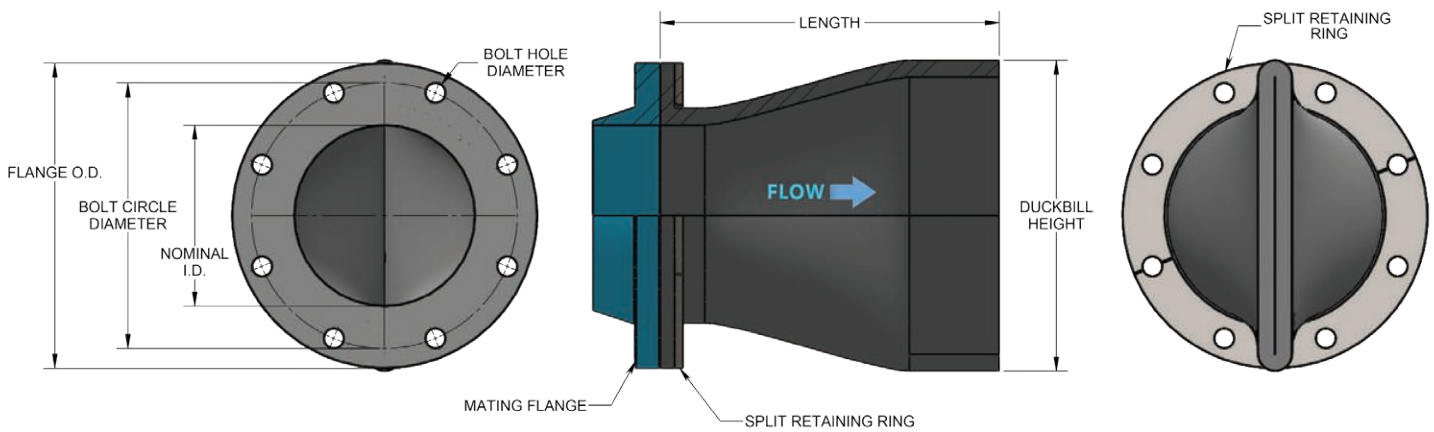
NOMINAL <sup>1</sup> PIPE SIZE Inch / (mm)	Standard Dimensions for PROCO Style 710			Standard Drilling for PROCO Style 710				WEIGHT <sup>2</sup> lbs / (kgs)
	Length Inch / (mm)	Duckbill Height Inch / (mm)	Flange O.D. Inch / (mm)	Bolt Circle Inch / (mm)	No. of Holes	Size of Holes Inch / (mm)		
<b>1</b>	(25)	6 (130)	2.60 (66)	4.25 (108.0)	3.13 (79.4)	4	0.625 (15.9)	2.0 (0.91)
<b>1.5</b>	(40)	7 (153)	3.20 (82)	5.00 (127.0)	3.88 (98.4)	4	0.625 (15.9)	2.50 (1.14)
<b>2</b>	(50)	7 (168)	3.90 (98)	6.00 (152.4)	4.75 (120.7)	4	0.750 (19.1)	5.00 (2.27)
<b>2.5</b>	(65)	8 (188)	5.10 (130)	7.00 (177.8)	5.50 (139.7)	4	0.750 (19.1)	6.00 (2.73)
<b>3</b>	(80)	9 (216)	5.50 (140)	7.50 (190.5)	6.00 (152.4)	4	0.750 (19.1)	8.00 (3.63)
<b>4</b>	(100)	11 (262)	7.40 (187)	9.00 (228.6)	7.50 (190.5)	8	0.750 (19.1)	11.00 (4.99)
<b>5</b>	(125)	12 (293)	9.40 (240)	10.00 (254.0)	8.50 (215.9)	8	0.875 (22.2)	13.00 (5.90)
<b>6</b>	(150)	13 (326)	10.50 (267)	11.00 (279.4)	9.50 (241.3)	8	0.875 (22.2)	17.00 (7.72)
<b>8</b>	(200)	15 (380)	13.70 (349)	13.50 (342.9)	11.75 (298.5)	8	0.875 (22.2)	27.00 (12.25)
<b>10</b>	(250)	18 (455)	17.30 (440)	16.00 (406.4)	14.25 (362.0)	12	1.000 (25.4)	40.00 (18.15)
<b>12</b>	(300)	21 (517)	20.50 (520)	19.00 (482.6)	17.00 (431.8)	12	1.000 (25.4)	53.00 (24.05)
<b>14</b>	(350)	24 (600)	24.20 (615)	21.00 (533.4)	18.75 (476.3)	12	1.150 (28.6)	64.00 (29.04)
<b>16</b>	(400)	25 (617)	27.60 (700)	23.50 (596.9)	21.25 (539.8)	16	1.150 (28.6)	93.00 (42.19)
<b>18</b>	(450)	27 (676)	31.10 (790)	25.00 (635.0)	22.75 (577.9)	16	1.250 (31.8)	135.00 (49.44)
<b>20</b>	(500)	30 (742)	32.30 (820)	27.50 (698.5)	25.00 (635.0)	20	1.250 (31.8)	155.00 (61.24)
<b>24</b>	(600)	39 (966)	38.60 (980)	32.00 (812.8)	29.50 (749.3)	20	1.375 (34.9)	235.00 (70.31)
<b>28</b>	(700)	42 (1060)	44.90 (1140)	36.50 (927.1)	34.00 (863.6)	28	1.375 (34.9)	420.00 (106.60)
<b>30</b>	(750)	44 (1097)	49.20 (1250)	38.75 (984.3)	36.00 (914.4)	28	1.375 (34.9)	565.00 (190.52)
<b>32</b>	(800)	45 (1140)	51.60 (1310)	41.75 (1060.5)	38.50 (977.9)	28	1.625 (41.3)	595.00 (256.29)
<b>36</b>	(900)	53 (1337)	59.40 (1510)	46.00 (1168.4)	42.75 (1085.9)	32	1.625 (41.3)	725.00 (269.90)
<b>40</b>	(1000)	54 (1353)	65.70 (1670)	50.75 (1289.1)	47.25 (1200.2)	36	1.625 (41.3)	845.00 (328.86)
<b>42</b>	(1050)	57 (1428)	67.30 (1710)	53.00 (1346.2)	49.50 (1257.3)	36	1.625 (41.3)	915.00 (383.29)
<b>48</b>	(1200)	64 (1613)	75.20 (1910)	59.50 (1511.3)	56.00 (1422.4)	44	1.625 (41.3)	1035.00 (415.05)
<b>54</b>	(1350)	68 (1726)	83.10 (2110)	66.25 (1682.8)	62.75 (1593.9)	44	2.000 (50.8)	1165.00 (469.48)
<b>60</b>	(1500)	74 (1875)	85.00 (2160)	73.00 (1854.2)	69.25 (1759.0)	52	2.000 (50.8)	1255.00 (569.27)
<b>72</b>	(1800)	87 (2197)	111.40 (2830)	86.50 (2197.1)	82.50 (2095.5)	60	2.000 (50.8)	1590.00 (721.22)

Notes: Higher back pressures can be provided by using internal vacuum supports and/or engineered Hi-Tensile reinforcement, contact PROCO

**Available Elastomers**  
Neoprene (Barnacle and Algae Resistant),  
NSF/ANSI Standard 61, EPDM, Nitrile,  
Natural Rubber, CSM and Chlorobutyl.



Detail of the *ProFlex™* Flanged Rubber Check Valve; Style 710



# PROCO STYLE 711

## ProFlex™ Flanged Slope Bottom Check Valves



The **Proco Style 711 ProFlex™** check valves are engineered for installation on pre-existing pipe lines such as manholes, outfalls, vaults, where the outfall invert of the pipe is close to the floor of the manhole or outfall. When a new installation is being designed, the 711 valves can be engineered into the pipe layout with little concern for outfall clearance due to its “low slope” design.

The new Style 711 check valves allow the valves to be installed without any costly and labor intensive changes to the existing structure. The 711 is engineered to crack open at 1-2” of head pressure and with its unique engineered sloping bottom, the valve ensures zero potential for standing water. With its all elastomer design, the valve can be installed without concern for the future seizing or rusting which can cause premature failure and maintenance issues.

### How Does it Work?

The advantage to the Style 711 is the sloping bottom which has been developed to offset the issues commonly affiliated with other flat bottom valves which often entrap solids and flows due to its design. The 711 has been carefully designed to prevent this issue and has a minimal slope which allows complete drainage yet still ensures easy installs on minimal clearance areas.

The Style 711 has been engineered to provide a full port which is important in dealing with headloss and jet velocities. The valve is manufactured with 100% algae and barnacle resistant rubber and is also 100% fire resistant.

### Advantages:

- Unique bottom slope design ensures 100% drainage
- Installs in flat outfall designs
- Available in both flanged and slip-on design
- An excellent choice for manholes and outfall installation
- Ensures sealing from rubbish and small solids

### Materials of Construction

Neoprene, ANSI/NSF-61 certified product elastomers, EPDM and other elastomers available.

Other materials also available. Please contact Proco.

### Mounting Clamps or Retaining Rings

304 or 316 Stainless Steel

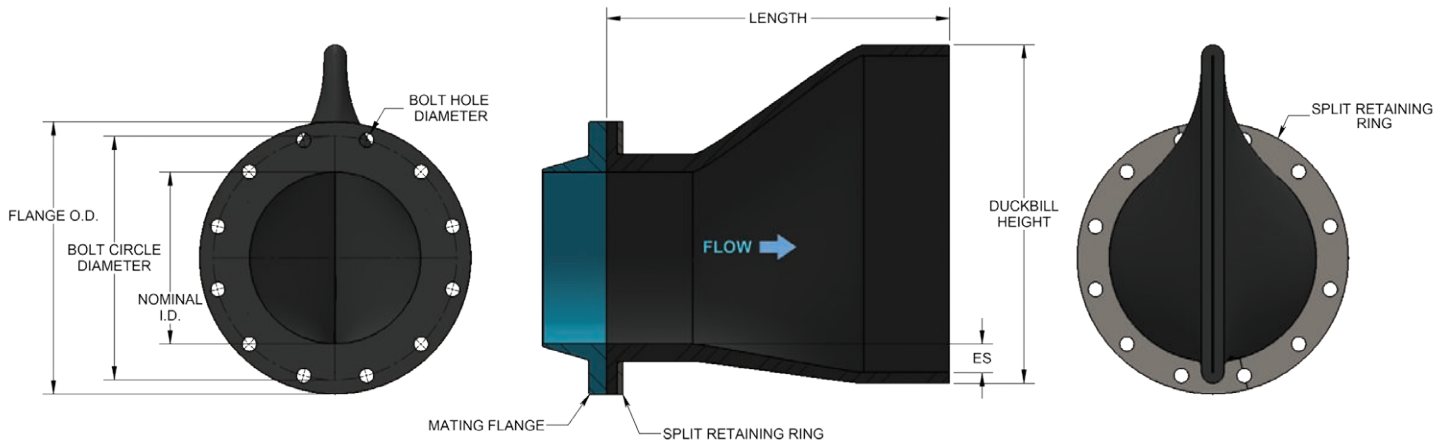
**Table 3: Sizes • Dimensions • Weights**

NOMINAL PIPE SIZE Inch / (mm)	Standard Dimensions					WEIGHT <sup>2</sup> lbs / (kgs)
	Length Inch / (mm)	Duckbill Height Inch / (mm)	Eccentric Slope “ES” Inch / (mm)			
<b>4</b>	(100)	10.9 (279)	8.8 (224)	1.0 (25)		15 (6.80)
<b>6</b>	(150)	17.9 (454)	14.8 (375)	2.0 (50)		23 (10.43)
<b>8</b>	(200)	19.8 (504)	17.7 (450)	2.0 (50)		36 (16.33)
<b>10</b>	(250)	21.8 (554)	20.5 (520)	2.0 (50)		52 (23.59)
<b>12</b>	(300)	24.0 (609)	23.6 (600)	2.0 (50)		53 (24)
<b>14</b>	(350)	25.9 (659)	26.4 (670)	2.0 (50)		64 (29)
<b>16</b>	(400)	27.9 (709)	29.9 (760)	2.0 (50)		93 (42.2)
<b>18</b>	(450)	29.7 (754)	33.1 (840)	2.0 (50)		135 (61.2)
<b>20</b>	(500)	31.7 (804)	36.2 (920)	2.0 (50)		155 (70.3)
<b>24</b>	(600)	37.6 (955)	42.9 (1090)	2.0 (50)		235 (106.6)
<b>30</b>	(750)	45.7 (1160)	54.7 (1390)	3.0 (75)		565 (256.3)
<b>36</b>	(900)	52.8 (1340)	65.7 (1670)	3.0 (75)		725 (328.9)
<b>42</b>	(1050)	54.3 (1380)	70.1 (1780)	3.0 (75)		915 (415)
<b>48</b>	(1200)	62.2 (1580)	80.7 (2050)	4.0 (100)		1035 (469.5)
<b>54</b>	(1350)	65.0 (1650)	86.6 (2200)	4.0 (100)		1165 (528.4)
<b>60</b>	(1500)	66.9 (1700)	94.5 (2400)	4.0 (100)		1255 (569.3)
<b>72</b>	(1800)	76.8 (1950)	114.2 (2900)	4.0 (100)		1590 (721.2)

Notes: Higher back pressures can be provided by using internal vacuum supports and/or engineered Hi-Tensile reinforcement, contact PROCO.



Detail of the *ProFlex™* Flanged/Slip-On Slope Bottom Check Valve; Style 711



The *ProFlex™* Slope-Bottom Style 711 & 731 Check Valves are covered by US PATENT NUMBER 11,221,081

# PROCO STYLE 731

## ProFlex™ Slip-On Slope Bottom Check Valves



The **Proco Style 731 ProFlex™** check valves are engineered for installation on pre-existing pipe lines such as manholes, outfalls, vaults, where the outfall invert of the pipe is close to the floor of the manhole or outfall. When a new installation is being designed, the 731 valves can be engineered into the pipe layout with little concern for outfall clearance due to its "low slope" design.

The new Style 731 check valves allow the valves to be installed without any costly and labor intensive changes to the existing structure. The 731 is engineered to crack open at 1-2" of head pressure and with its unique engineered sloping bottom, the valve ensures zero potential for standing water. With its all elastomer design, the valve can be installed without concern for the future seizing or rusting which can cause premature failure and maintenance issues.

### How Does it Work?

The advantage to the Style 731 is the sloping bottom which has been developed to offset the issues commonly affiliated with other flat bottom valves which often entrap solids and flows due to its design. The 731 has been carefully designed to prevent this issue and has a minimal slope which allows complete drainage yet still ensures easy installs on minimal clearance areas.

The Style 731 has been engineered to provide a full port which is important in dealing with headloss and jet velocities. The valve is manufactured with 100% algae and barnacle resistant rubber and is also 100% fire resistant.

### Advantages:

- Unique bottom slope design ensures 100% drainage
- Installs in flat outfall designs
- Available in both flanged and slip-on design
- An excellent choice for manholes and outfall installation
- Ensures sealing from rubbish and small solids

### Materials of Construction

Neoprene, ANSI/NSF-61 certified product elastomers, EPDM and other elastomers available.

Other materials also available. Please contact Proco.

### Mounting Clamps or Retaining Rings

304 or 316 Stainless Steel

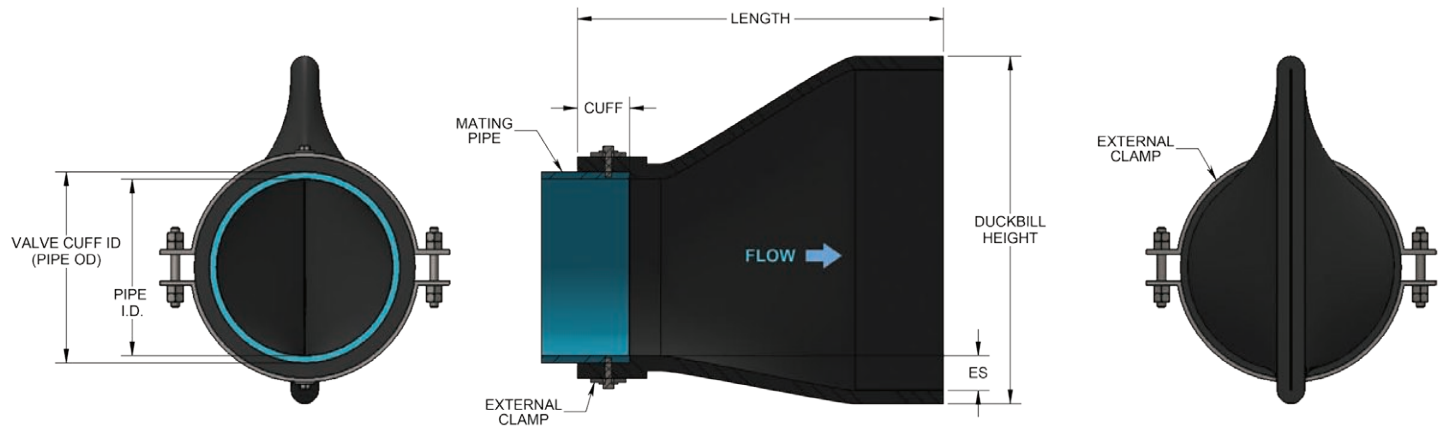
**Table 4: Sizes • Dimensions • Weights**

NOMINAL PIPE SIZE Inch / (mm)	Standard Dimensions						WEIGHT <sup>2</sup> lbs / (kgs)
	Cuff Width Inch / (mm)	Length Inch / (mm)	Duckbill Height Inch / (mm)	Eccentric Slope "ES" Inch / (mm)			
<b>4</b>	(100)	3.00 (76)	12.8 (326)	8.8 (224)	1.0 (25)	15 (6.80)	
<b>6</b>	(150)	4.00 (102)	17.9 (454)	14.8 (375)	2.0 (50)	23 (10.43)	
<b>8</b>	(200)	4.00 (102)	19.8 (504)	17.7 (450)	2.0 (50)	36 (16.33)	
<b>10</b>	(250)	4.00 (102)	21.8 (554)	20.5 (520)	2.0 (50)	52 (23.59)	
<b>12</b>	(300)	6.00 (152)	27.9 (709)	23.6 (600)	2.0 (50)	59 (26.8)	
<b>14</b>	(350)	6.00 (152)	29.9 (759)	26.4 (670)	2.0 (50)	76 (34.5)	
<b>16</b>	(400)	6.00 (152)	31.9 (809)	29.9 (760)	2.0 (50)	90 (40.8)	
<b>18</b>	(450)	6.00 (152)	33.6 (854)	33.1 (840)	2.0 (50)	130 (59)	
<b>20</b>	(500)	8.00 (203)	37.5 (952)	36.2 (920)	2.0 (50)	200 (90.7)	
<b>24</b>	(600)	8.00 (203)	43.3 (1100)	42.9 (1090)	2.0 (50)	215 (97.5)	
<b>30</b>	(750)	10.00 (254)	51.7 (1314)	54.7 (1390)	3.0 (76)	460 (208.7)	
<b>36</b>	(900)	10.00 (254)	59.4 (1510)	65.7 (1670)	3.0 (76)	585 (265.4)	
<b>42</b>	(1050)	12.00 (305)	61.0 (1550)	70.1 (1780)	3.0 (76)	1075 (487.6)	
<b>48</b>	(1200)	12.00 (305)	68.1 (1730)	80.7 (2050)	3.9 (100)	1350 (612.3)	
<b>54</b>	(1350)	12.00 (305)	70.9 (1800)	86.6 (2200)	3.9 (100)	1630 (739.4)	
<b>60</b>	(1500)	12.00 (305)	75.0 (1905)	94.5 (2400)	3.9 (100)	1715 (777.9)	
<b>72</b>	(1800)	12.00 (305)	84.8 (2155)	114.2 (2900)	3.9 (100)	1900 (861.8)	

Notes: Higher back pressures can be provided by using internal vacuum supports and/or engineered Hi-Tensile reinforcement, contact PROCO.



Detail of the *ProFlex™* Flanged/Slip-On Slope Bottom Check Valve; Style 731



The *ProFlex™* Slope-Bottom Style 711 & 731 Check Valves are covered by US PATENT NUMBER 11,221,081



# PROCO STYLE 730

## ProFlex™ Slip-on Rubber Check Valves



The **ProFlex™ 730** Slip-on Rubber Duckbill Check Valve is designed to slip directly over an existing pipe, and is supplied with heavy duty stainless steel clamp(s) to secure it in place. Sizes 1" - 10" utilize T-Bolt clamps and sizes above 10" utilize Bolt-On Clamps for securing.

For higher pressure/vacuum requirements, the **ProFlex™ 730** Slip-on Rubber Duckbill Check Valve can also be manufactured using a unique Internal Vacuum Supports (IVS) design which is homogeneous to the inner reinforced layers of the valve allowing a full flow with no obstructions and yet providing excellent anti-inversion features.

The **ProFlex™ 730** Slip-on Rubber Duckbill Check Valve can be designed and manufactured to slip over any outside diameter pipe including oval and rectangular configurations.

**Table 5: Sizes • Weights**

NOMINAL 1 PIPE SIZE Inch / (mm)	Standard Dimensions for PROCO Style 730			WEIGHT 2 lbs / (kgs)	
	Cuff Width Inch / (mm)	Length Inch / (mm)	Duckbill Height Inch / (mm)		
1	(25)	1.00 (25)	4 (105)	2.60 (66)	0.5 (0.30)
1.5	(40)	1.00 (25)	5 (128)	3.20 (82)	0.75 (0.40)
2	(50)	2.00 (38)	6 (156)	3.90 (98)	2.5 (1.20)
2.5	(65)	2.00 (51)	7 (189)	5.10 (130)	3 (1.40)
3	(80)	3.00 (76)	10 (242)	5.50 (140)	5 (2.30)
4	(100)	3.00 (76)	12 (308)	7.40 (187)	7 (3.20)
5	(125)	3.00 (76)	13 (339)	9.40 (240)	10 (4.60)
6	(150)	4.00 (102)	18 (395)	10.50 (267)	12 (5.50)
8	(200)	4.00 (102)	18 (452)	13.70 (349)	20 (9.10)
10	(250)	4.00 (102)	21 (527)	17.30 (440)	33 (15.00)
12	(300)	6.00 (152)	26 (669)	20.50 (520)	59 (26.80)
14	(350)	6.00 (152)	30 (733)	24.20 (584)	76 (34.50)
16	(400)	6.00 (152)	33 (769)	27.60 (615)	90 (40.90)
18	(450)	6.00 (152)	36 (828)	31.10 (700)	130 (59.00)
20	(500)	8.00 (203)	37 (945)	32.30 (790)	200 (90.80)
24	(600)	8.00 (203)	44 (1119)	38.60 (820)	215 (97.60)
28	(700)	8.00 (203)	48 (1213)	44.90 (980)	365 (165.60)
30	(750)	10.00 (254)	51 (1301)	49.20 (1140)	460 (208.70)
32	(800)	10.00 (254)	53 (1344)	51.60 (1310)	495 (224.60)
36	(900)	10.00 (254)	61 (1541)	59.40 (1510)	585 (265.40)
40	(1000)	12.00 (305)	62 (1570)	65.80 (1670)	825 (374.20)
42	(1050)	12.00 (305)	66 (1683)	67.30 (1710)	1075 (487.70)
48	(1200)	12.00 (305)	74 (1868)	75.20 (1910)	1350 (612.40)
54	(1350)	12.00 (305)	78 (1981)	83.10 (2110)	1630 (739.40)
60	(1500)	12.00 (305)	84 (2130)	85.00 (2160)	1715 (778.00)
72	(1800)	12.00 (305)	97 (2452)	111.40 (2830)	1900 (861.90)



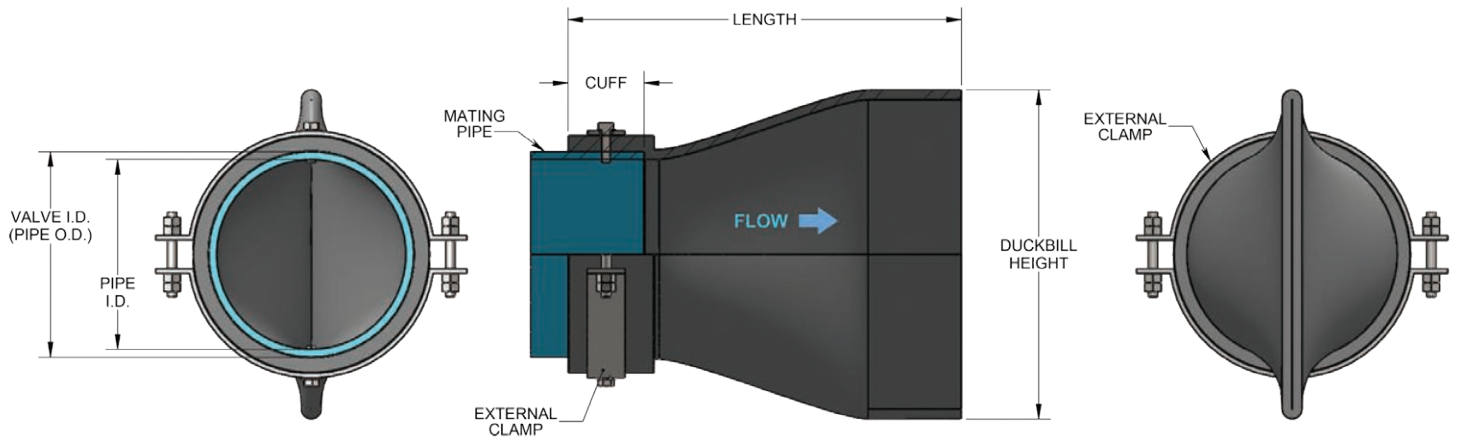
Notes: Higher back pressures can be provided by using internal vacuum supports and/or reinforced HV-Tex® reinforcement, contact PROCO.

**Available Elastomers**

Neoprene (Barnacle and Algae Resistant),  
NSF/ANSI Standard 61, EPDM, Nitrile,  
Natural Rubber, CSM and Chlorobutyl.



Detail of the *ProFlex™* Slip-on Rubber Check Valve; Style 730



# PROCO STYLE 720

## ProFlex™ In-line Flanged Rubber Check Valves



The **ProFlex™ 720** Flanged In-line Rubber Duckbill Check Valve is designed to fit directly inside of an existing pipe. The unique advantage of this valve is that it can be slipped inside of the pipe and installed between existing pipe flanges, and eliminates the need for a valve body.

The **ProFlex™ 720** Flanged In-line Rubber Duckbill Check Valve comes standard with ANSI 125/150# flange drilling and can also be supplied with ANSI 250/300, DIN, JIS, BS or AS flange patterns.

All **ProFlex™ 720** Flanged In-line Rubber Duckbill Check Valves are special manufactured valves suited to your pipe I.D. and are available up to 96" in diameter and can also be custom manufactured to meet specific head and back pressures.

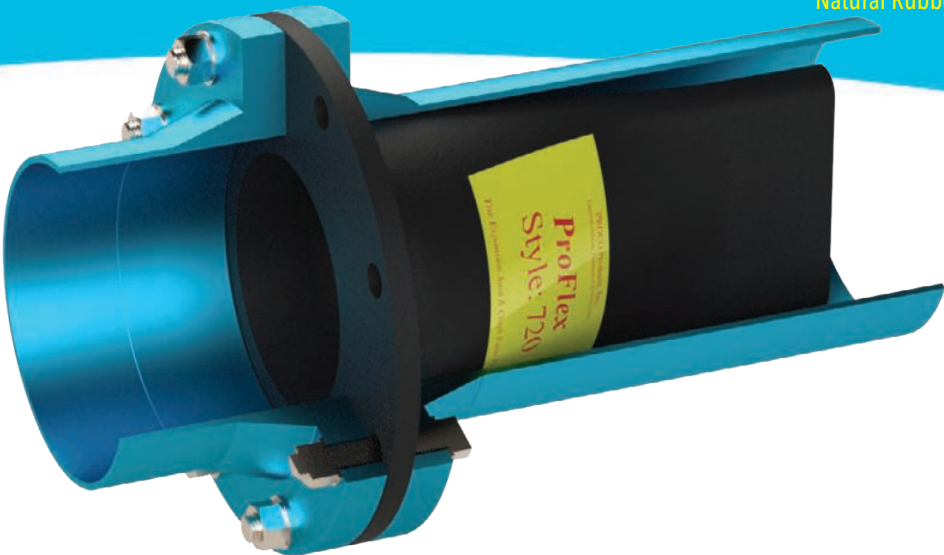
For higher pressure/vacuum requirements, the **ProFlex™ 720** Flanged In-line Rubber Duckbill Check Valve can also be manufactured using a unique Internal Vacuum Supports (IVS) design which is homogeneous to the inner reinforced layers of the valve allowing a full flow with no obstructions and yet providing excellent anti-inversion features.

**Table 6: Sizes • Flange Drilling • Working Pressures • Weights**

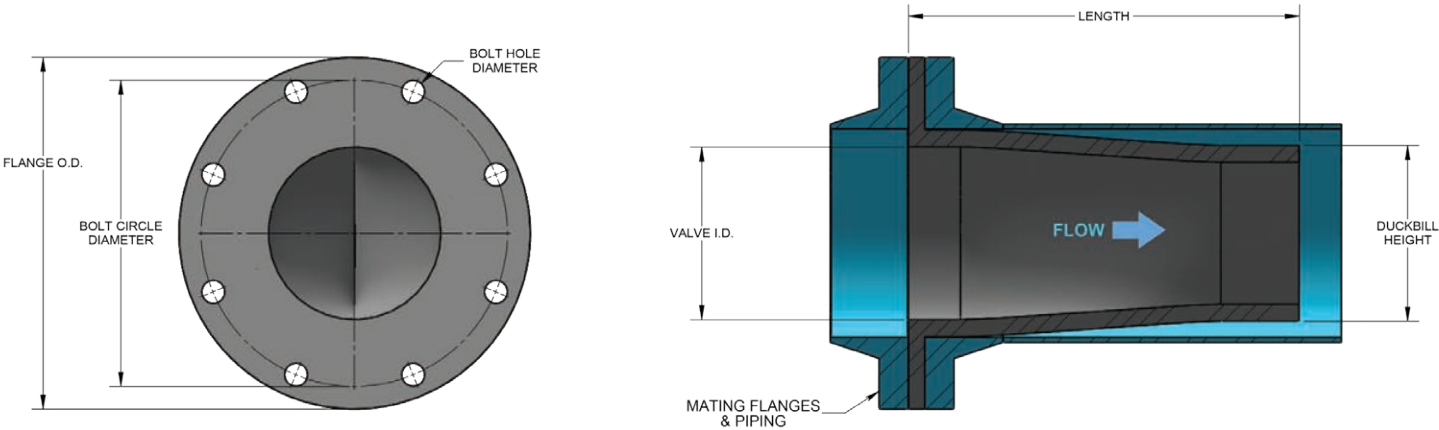
NOMINAL <sup>1</sup> PIPE SIZE Inch / (mm)	Standard Dimensions for PROCO Style 720		Standard Drilling for PROCO Style 720				MAXIMUM WORKING PRESSURE (PSIG)	WEIGHT <sup>2</sup> lbs / (kgs)
	Length Inch / (mm)	Duckbill Height Inch / (mm)	Flange O.D. Inch / (mm)	Bolt Circle Inch / (mm)	No. of Holes	Size of Holes Inch / (mm)		
<b>2</b> (50)	7 (175)	1.90 (48)	6.00 (152.4)	4.75 (120.7)	4	0.750 (19.1)	125	2.00 (1.4)
<b>3</b> (80)	9 (225)	2.90 (73)	7.50 (190.5)	6.00 (152.4)	4	0.750 (19.1)	125	3.00 (1.8)
<b>4</b> (100)	10 (252)	3.60 (90)	9.00 (228.6)	7.50 (190.5)	8	0.750 (19.1)	100	5.00 (3.6)
<b>6</b> (150)	12 (300)	5.60 (140)	11.00 (279.4)	9.50 (241.3)	8	0.875 (22.2)	75	8.00 (5.4)
<b>8</b> (200)	15 (390)	7.10 (180)	13.50 (342.9)	11.75 (298.5)	8	0.875 (22.2)	75	11.00 (5.9)
<b>10</b> (250)	19 (483)	9.90 (251)	16.00 (406.4)	14.25 (362.0)	12	1.000 (25.4)	50	18.00 (13.2)
<b>12</b> (300)	21 (533)	11.90 (302)	19.00 (482.6)	17.00 (431.8)	12	1.000 (25.4)	50	29.00 (16.8)
<b>14</b> (350)	22 (558)	12.30 (310)	21.00 (533.4)	18.75 (476.3)	12	1.150 (28.6)	50	48.00 (18.6)
<b>16</b> (400)	23 (572)	15.00 (380)	23.50 (596.9)	21.25 (539.8)	16	1.150 (28.6)	50	54.00 (22.7)
<b>18</b> (450)	29 (732)	16.60 (420)	25.00 (635.0)	22.75 (577.9)	16	1.250 (31.8)	25	65.00 (71.7)
<b>20</b> (500)	28 (710)	18.90 (480)	27.50 (698.5)	25.00 (635.0)	20	1.250 (31.8)	25	95.00 (106.1)
<b>24</b> (600)	34 (860)	22.10 (560)	32.00 (812.8)	29.50 (749.3)	20	1.375 (34.9)	25	165.00 (139.7)
<b>28</b> (700)	39 (980)	26.40 (670)	36.50 (927.1)	34.00 (863.6)	28	1.375 (34.9)	25	253.00 (164.2)
<b>30</b> (750)	53 (1354)	29.10 (738)	38.75 (984.3)	36.00 (914.4)	28	1.375 (34.9)	25	305.00 (189.1)
<b>36</b> (900)	53 (1346)	35.80 (909)	46.00 (1168.4)	42.75 (1085.9)	32	1.625 (41.3)	25	615.00 (226.3)
<b>42</b> (1,050)	54 (1380)	40.60 (1030)	53.00 (1346.2)	49.50 (1257.3)	36	1.625 (41.3)	25	695.00 (330.7)
<b>48</b> (1,200)	61 (1555)	46.50 (1180)	59.50 (1511.3)	56.00 (1422.4)	44	1.625 (41.3)	25	735.00 (342.0)
<b>54</b> (1,350)	65 (1650)	53.20 (1350)	66.25 (1682.8)	62.75 (1593.9)	44	2.000 (50.8)	25	1095.00 (368.8)
<b>60</b> (1,500)	71 (1800)	58.70 (1490)	73.00 (1854.2)	69.25 (1759.0)	52	2.000 (50.8)	25	1255.00 (437.3)
<b>72</b> (1,800)	81 (2050)	70.50 (1790)	86.50 (2197.1)	82.50 (2095.5)	60	2.000 (50.8)	25	1590.00 (510.3)

**Available Elastomers**

Neoprene (Barnacle and Algae Resistant),  
NSF/ANSI Standard 61, EPDM, Nitrile,  
Natural Rubber, CSM and Chlorobutyl.



Detail of the *ProFlex™* In-line Flanged Rubber Check Valve; Style 720



# PROCO STYLE 740

## ProFlex™ Slip-in Style In-line Rubber Check Valves



The **ProFlex™ 740** In-line Rubber Duckbill Check Valve is designed to fit directly inside of an existing pipe, and is supplied with a stainless steel internal expandable clamp to secure it in place.

For higher pressure/vacuum requirements, the **ProFlex™ 740** In-line Rubber Duckbill Check Valve can also be manufactured using a unique Internal Vacuum Supports (IVS) design which is homogeneous to the inner reinforced layers of the valve allowing full flow with no obstructions and yet providing excellent anti-inversion features.

**Table 7: Sizes • Working Pressures • Weights**

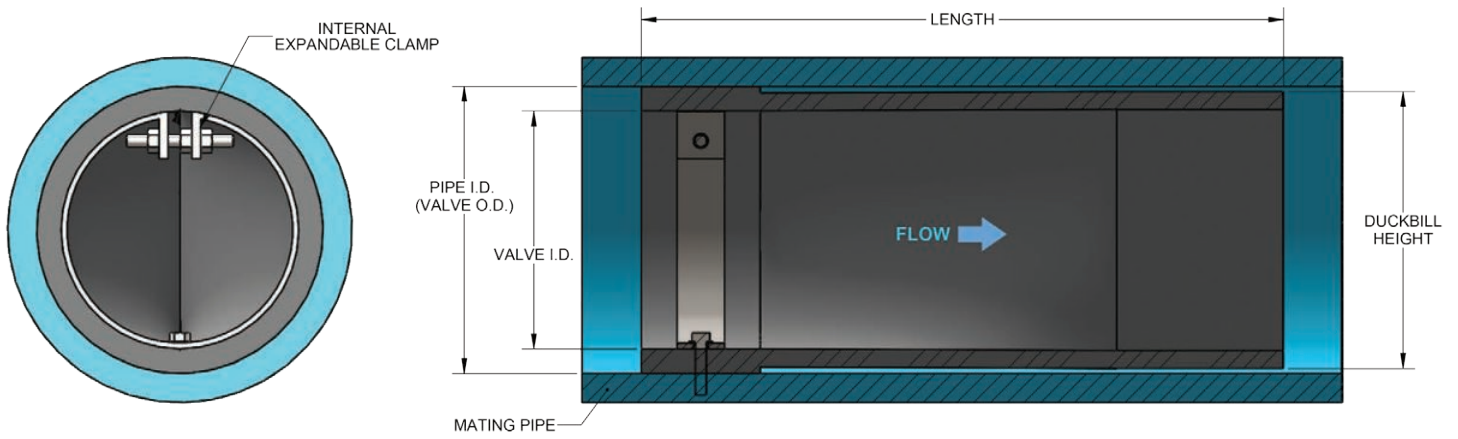
NOMINAL <sup>1</sup> PIPE SIZE Inch / (mm)	Standard Dimensions for PROCO Style 740			MAXIMUM WORKING PRESSURE (PSIG)	WEIGHT <sup>2</sup> lbs / (kgs)	
	Cuff Width Inch / (mm)	Length Inch / (mm)	Duckbill Height Inch / (mm)			
<b>2</b>	(50)	1.50 (38)	7 (173)	1.89 (48)	125	2 (0.91)
<b>3</b>	(80)	2.99 (76)	10 (261)	2.87 (73)	125	3 (1.37)
<b>4</b>	(100)	2.99 (76)	11 (288)	3.54 (90)	100	4 (1.82)
<b>6</b>	(150)	4.02 (102)	14 (362)	5.51 (140)	75	12 (5.45)
<b>8</b>	(200)	4.02 (102)	18 (452)	7.09 (180)	75	14 (6.36)
<b>10</b>	(250)	4.02 (102)	22 (558)	9.90 (251)	50	17 (7.72)
<b>12</b>	(300)	5.98 (152)	24 (610)	11.90 (302)	50	27 (12.25)
<b>14</b>	(350)	5.98 (152)	26 (670)	12.20 (310)	50	39 (17.70)
<b>16</b>	(400)	5.98 (152)	27 (684)	14.96 (380)	50	44 (19.96)
<b>18</b>	(450)	5.98 (152)	33 (844)	16.54 (420)	25	72 (32.66)
<b>20</b>	(500)	7.99 (203)	34 (873)	18.90 (480)	25	110 (49.90)
<b>24</b>	(600)	7.99 (203)	38 (973)	22.05 (560)	25	125 (56.70)
<b>28</b>	(700)	7.99 (203)	43 (1093)	26.38 (670)	25	215 (97.53)
<b>30</b>	(750)	10.00 (254)	60 (1518)	29.06 (738)	25	415 (188.25)
<b>36</b>	(900)	10.00 (254)	62 (1575)	35.80 (909)	25	770 (349.27)
<b>42</b>	(1050)	12.00 (305)	63 (1595)	40.55 (1030)	25	800 (362.88)
<b>48</b>	(1200)	12.00 (305)	70 (1770)	46.46 (1180)	25	920 (417.31)
<b>54</b>	(1350)	12.00 (305)	73 (1865)	53.15 (1350)	25	1110 (503.50)
<b>60</b>	(1500)	12.00 (305)	79 (2015)	58.66 (1490)	25	1200 (544.32)
<b>72</b>	(1800)	12.00 (305)	89 (2265)	70.47 (1790)	25	1450 (657.72)

Notes: Higher back pressures can be provided by using internal vacuum supports and/or engineered Hi-Tensile reinforcement, contact PROCO.



**Available Elastomers**  
 Neoprene (Barnacle and Algae Resistant),  
 NSF/ANSI Standard 61, EPDM, Nitrile,  
 Natural Rubber, CSM and Chlorobutyl.

Detail of the *ProFlex*<sup>TM</sup> Slip-in In-line Rubber Check Valve; Style 740



# PROCO STYLE 750



## ProFlex™ Jacketed In-line Flanged Rubber Check Valves

### Unique Features

- Maintenance free
- Will seal even with solids entrapment
- Designed to withstand wear
- Quiet operation, no water hammer!
- 100% backflow prevention
- Tough enough for abrasive slurries
- No body halves with problematic sealing issues

The **ProFlex™ 750** is designed to be the answer to enclosed body check valve requirements for slurry applications. It requires no external power sources, thereby making operation costs obsolete.

The valve's unique design means there are no mechanical parts to break down or wear therefore reducing maintenance costs.

The **ProFlex™ 750** easily allows flow of abrasive materials such as raw sewage, sludges or slurries. The elastomer's flexible design allows the media to flow without significant head losses and will seal around solids trapped in the valve.

The **ProFlex™ 750** valves are versatile and can be installed either horizontally or vertically and are designed within industry standards for flange size and drilling.

Vacuum supports can be supplied independent to the valve as well as internal supports which can ensure back pressures up to 600 psi depending on pipe size.

### Applications

Potable Water Outfalls - Stand Pipes - Sewer Interceptors - Wet Wells - Mine Tailing Pipeline outfalls - Dredging - Scrubber Pipe Systems - Outfall Lines - Pneumatic Conveying- Pump Backflow Protection

### Construction

The solid carbon steel body (optional materials are available) and one-piece rubber valve provide lasting durability. The unique feature is the pull through design which provides a tamper proof valve required for Homeland Security Issues. The 2 flush ports allows for easy cleaning of the valve's interior body.

### Replacement Costs?

Cost Effective and Simple! The inner sleeve is a standard **ProFlex™ 710** readily available for quick replacement if the sleeve does need unlikely replacement.



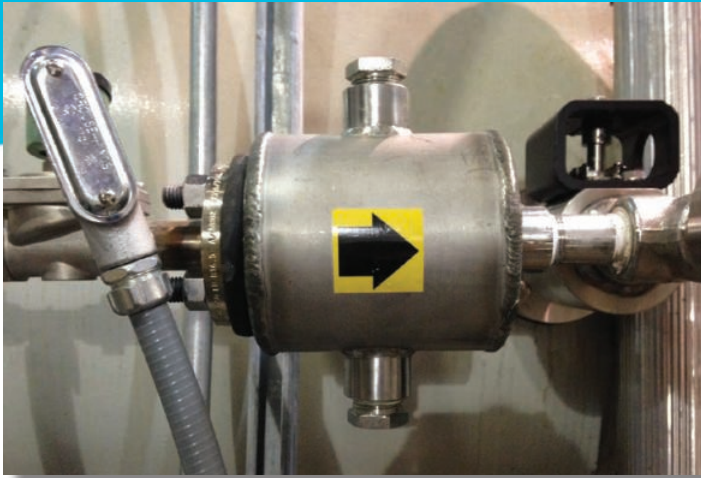
**Table 8: Sizes • Dimensions • Working Pressure**

NOMINAL PIPE SIZE		D Length		C Height (Max. Dimension)		W Width (Max. Body O.D.)		Working Pressure	
in.	mm	in.	mm	in.	mm	in.	mm	PSI	Bar
<b>1</b>	<b>25</b>	8.4	214	5.5	140	7.9	200	125	8.6
<b>1.25</b>	<b>32</b>	8.8	224	5.5	140	7.9	200	125	8.6
<b>1.5</b>	<b>40</b>	9.2	233	5.5	140	7.9	200	125	8.6
<b>2</b>	<b>50</b>	9.8	250	8.5	216	11.4	290	125	8.6
<b>2.5</b>	<b>65</b>	10.7	271	8.5	216	11.4	290	125	8.6
<b>3</b>	<b>80</b>	12.6	321	9.5	241	12.4	315	125	8.6
<b>4</b>	<b>100</b>	16.9	429	10.5	267	13.4	341	125	8.6
<b>6</b>	<b>150</b>	22.0	559	12.8	325	16.3	415	100	6.9
<b>8</b>	<b>200</b>	24.4	619	15.8	401	19.3	491	100	8.6
<b>10</b>	<b>250</b>	26.6	676	20.8	528	24.3	618	75	5.2
<b>12</b>	<b>300</b>	28	711	24.8	630	28.3	720	75	5.2
<b>14</b>	<b>350</b>	34.3	872	26.8	680	30.3	770	50	3.4
<b>16</b>	<b>400</b>	37.2	946	30.7	780	34.3	870	50	3.4
<b>18</b>	<b>450</b>	38.4	975	34.6	880	38.3	970	50	3.4
<b>20</b>	<b>500</b>	39.4	1002	36.6	930	40.2	1020	50	3.4
<b>24</b>	<b>600</b>	51.0	1295	43.0	1091	46.3	1181	50	3.4

Notes: Higher back pressures can be provided by using internal vacuum supports and/or engineered Hi-Tensile reinforcement, contact PROCO.

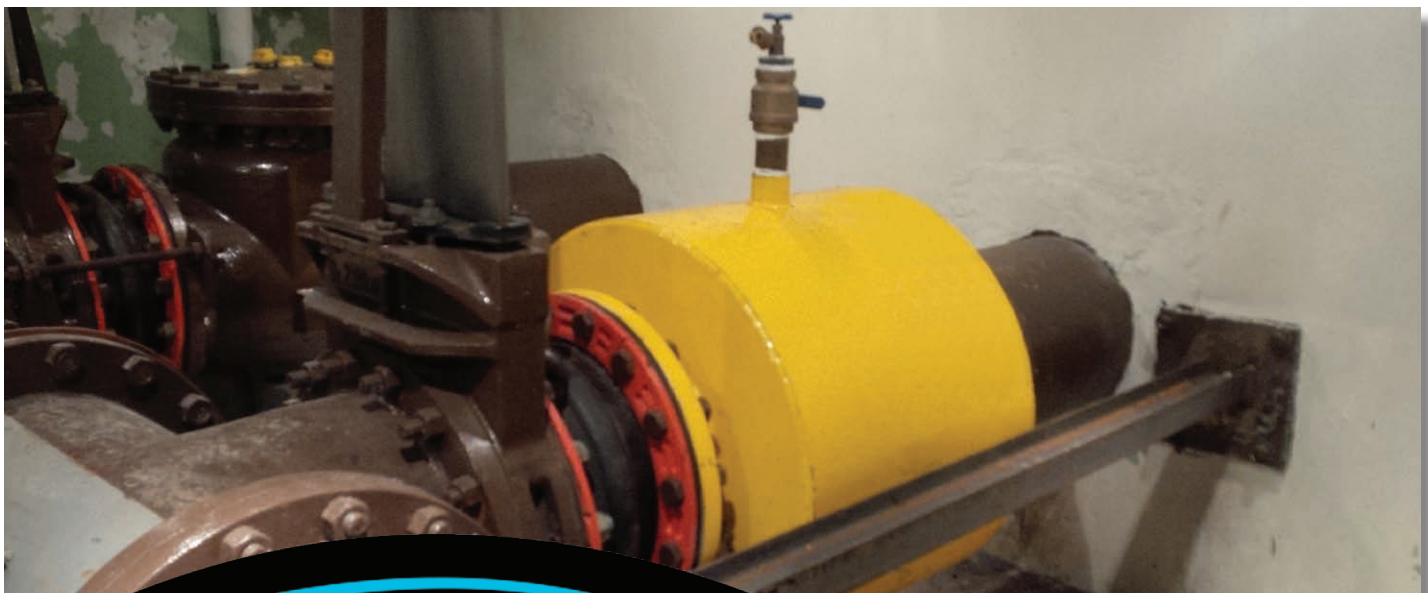
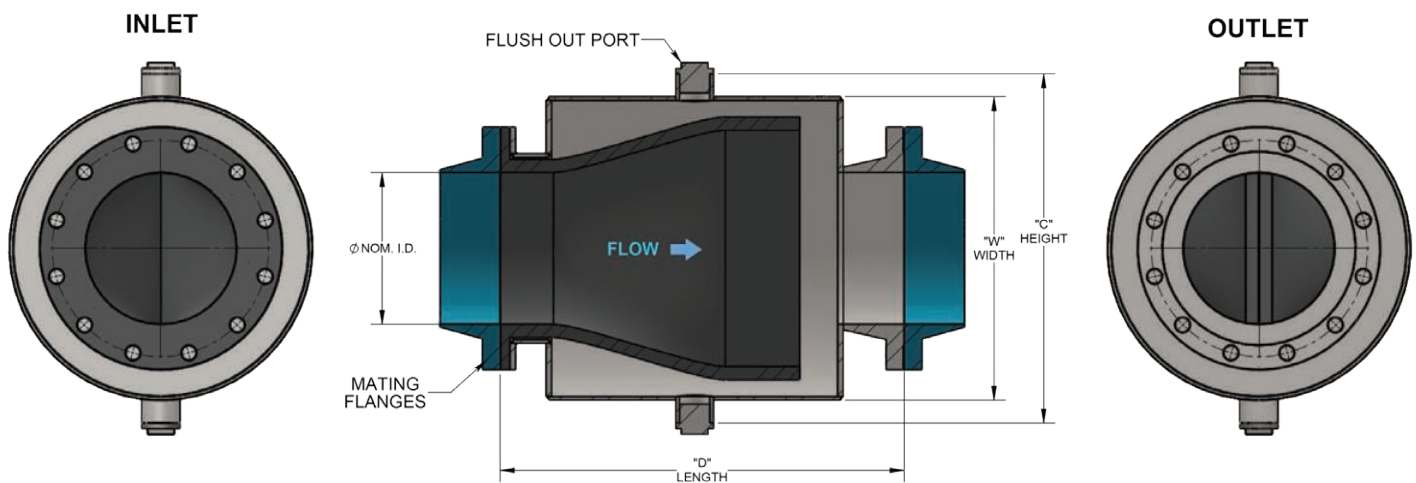
### Available Elastomers

Neoprene (Barnacle and Algae Resistant),  
NSF/ANSI Standard 61, EPDM, Nitrile,  
Natural Rubber, CSM and Chlorobutyl.



***Vacuum and high back pressure supports ensure continued protection in severe back flow conditions***

Detail of the *ProFlex™* Jacketed In-line Flanged Rubber Check Valve; Style 750



# PROCO STYLE 770

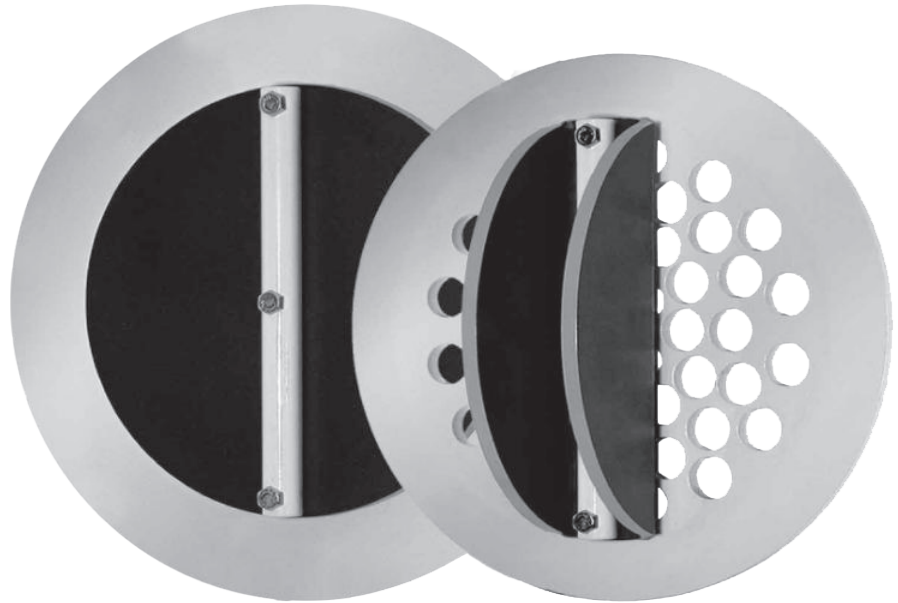
**Available Elastomers**  
Neoprene (Barnacle and Algae Resistant),  
NSF/ANSI Standard 61, EPDM, Nitrile,  
Natural Rubber, CSM and Chlorobutyl.

## ProFlex™ Wafer Style In-line Rubber Check Valves

The **ProFlex™ 770/780** Wafer Style In-line Rubber Check Valves are designed to be installed between two mating flanges and offers space saving dimensions as opposed to other flap type check valves.

The **ProFlex™ 780** Wafer Style In-line Rubber Check Valve comes standard with ANSI 125/150# flange drilling and can also be supplied with ANSI 250/300, DIN, JIS, BS or AS flange patterns.

The **ProFlex™ 770** Wafer Style In-line Rubber Check Valve Is designed to fit securely inside the bolt circle of the mating flanges.

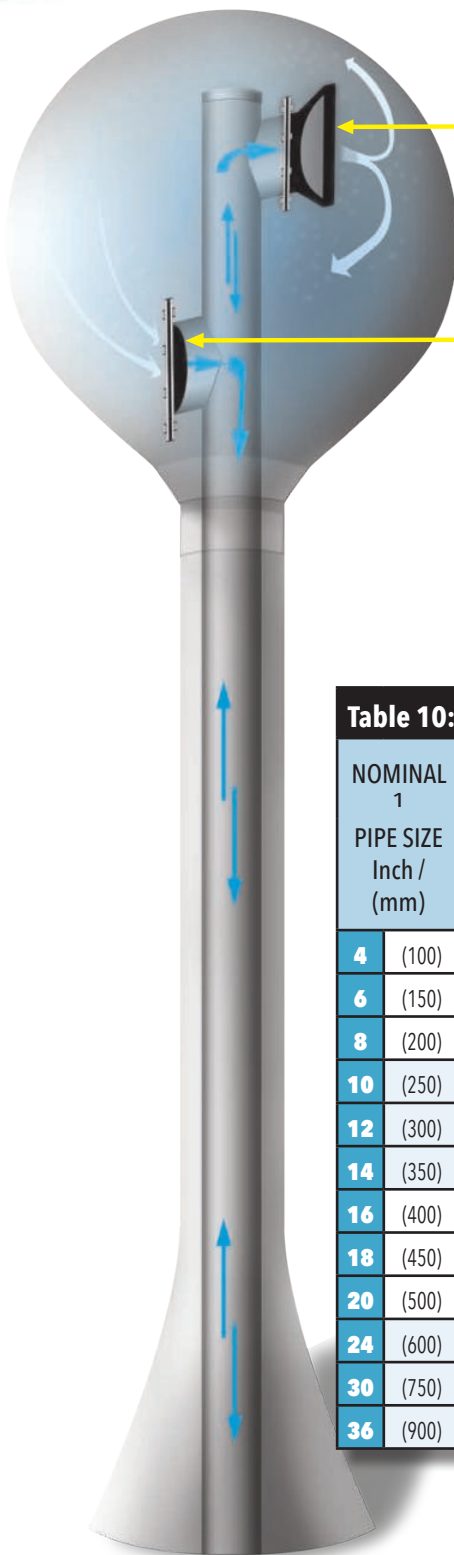


**Table 9: Sizes • Dimensions • Flow Data**

NOMINAL <sup>1</sup> PIPE SIZE Inch / (mm)	Standard Dimensions for PROCO Style 770		Back Pressure PSIG / (bar)	VELOCITY (ft/s) vs. HEADLOSS (ft) <sup>2</sup>					
	Plate Thickness Inch / (mm)	Plate O.D. Inch / (mm)		1	2	4	6	8	10
<b>4</b> (100)	0.250 (6.35)	6.19 (157.23)	150 (10.0)	0.40	1.29	3.97	6.18	8.17	9.83
<b>6</b> (150)	0.250 (6.35)	8.50 (215.90)	150 (10.0)	0.44	1.48	4.31	6.54	8.50	10.16
<b>8</b> (200)	0.375 (9.53)	10.63 (270.00)	150 (10.0)	0.48	1.67	4.64	6.91	8.84	10.48
<b>10</b> (250)	0.375 (9.53)	12.75 (323.85)	150 (10.0)	0.52	1.86	4.98	7.27	9.17	10.81
<b>12</b> (300)	0.500 (12.70)	15.00 (381.00)	150 (10.0)	0.56	2.05	5.32	7.63	9.51	11.14
<b>14</b> (350)	0.500 (12.70)	16.25 (412.75)	150 (10.0)	1.18	2.77	5.82	8.02	9.79	11.37
<b>16</b> (400)	0.750 (19.05)	18.00 (457.20)	150 (10.0)	1.80	3.50	6.33	8.41	10.08	11.60
<b>18</b> (450)	0.750 (19.05)	19.88 (504.95)	150 (10.0)	2.42	4.23	6.84	8.79	10.37	11.83
<b>20</b> (500)	0.750 (19.05)	22.00 (558.80)	150 (10.0)	2.82	4.69	7.17	9.05	10.56	11.98
<b>24</b> (600)	1.000 (25.40)	27.25 (692.15)	150 (10.0)	2.86	4.75	7.24	9.12	10.64	12.06
<b>30</b> (750)	1.000 (25.40)	34.50 (876.30)	150 (10.0)	2.93	4.84	7.35	9.21	10.75	12.17
<b>36</b> (900)	1.000 (25.40)	41.00 (1041.40)	150 (10.0)	2.99	4.93	7.46	9.31	10.86	12.28

# PROCO STYLE 780

## ProFlex™ Wafer Style In-line Flanged Rubber Check Valves

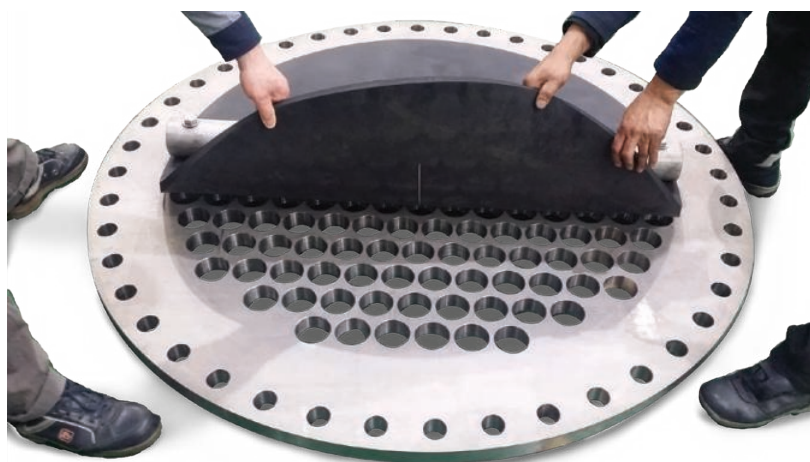


### Inlet Valves

- ProFlex™ Style 710
- Opens during tank filling
- Provides complete mixing with optimal jet velocities
- Closed during tank draining

### Outlet Valves

- ProFlex™ Style 780
- Closed during tank filling
- Opens for tank draining



**Table 10: Sizes • Dimensions • Drilling • Flow Data**

NOMINAL 1 PIPE SIZE Inch / (mm)	Standard Dimensions for PROCO Style 780						Back Pressure PSIG / (Bar)	VELOCITY (ft/s) vs. HEADLOSS (ft) <sup>2</sup>					
	Plate Thickness Inch / (mm)	Flange O.D. Inch / (mm)	Bolt Circle Inch / (mm)	No. of Holes	Size of Holes Inch / (mm)	1		2	4	6	8	10	
4 (100)	0.250 (6.35)	9.00 (228.60)	7.50 (190.50)	8	0.750 (19.1)	150 (10.0)	0.40	1.29	3.97	6.18	8.17	9.83	
6 (150)	0.250 (6.35)	11.00 (279.40)	9.50 (241.30)	8	0.875 (22.2)	150 (10.0)	0.44	1.48	4.31	6.54	8.50	10.16	
8 (200)	0.375 (9.53)	13.50 (342.90)	11.75 (298.45)	8	0.875 (22.2)	150 (10.0)	0.48	1.67	4.64	6.91	8.84	10.48	
10 (250)	0.375 (9.53)	16.00 (406.40)	14.25 (361.95)	12	1.000 (25.4)	150 (10.0)	0.52	1.86	4.98	7.27	9.17	10.81	
12 (300)	0.500 (12.70)	19.00 (482.60)	17.00 (431.80)	12	1.000 (25.4)	150 (10.0)	0.56	2.05	5.32	7.63	9.51	11.14	
14 (350)	0.500 (12.70)	21.00 (533.40)	18.75 (476.25)	12	1.250 (31.8)	150 (10.0)	1.18	2.77	5.82	8.02	9.79	11.37	
16 (400)	0.750 (19.05)	23.50 (596.90)	21.25 (539.75)	16	1.250 (31.8)	150 (10.0)	1.80	3.50	6.33	8.41	10.08	11.60	
18 (450)	0.750 (19.05)	25.00 (635.00)	22.75 (577.85)	16	1.250 (31.8)	150 (10.0)	2.42	4.23	6.84	8.79	10.37	11.83	
20 (500)	0.750 (19.05)	27.50 (698.50)	25.00 (635.00)	20	1.250 (31.8)	150 (10.0)	2.82	4.69	7.17	9.05	10.37	11.98	
24 (600)	1.000 (25.40)	32.00 (812.80)	29.50 (749.30)	20	1.375 (34.9)	150 (10.0)	2.86	4.75	7.24	9.12	10.56	12.06	
30 (750)	1.000 (25.40)	38.75 (984.25)	36.00 (914.40)	28	1.375 (34.9)	150 (10.0)	2.93	4.84	7.35	9.21	10.75	12.17	
36 (900)	1.000 (25.40)	46.00 (1168.40)	42.75 (1085.85)	32	1.625 (41.3)	150 (10.0)	2.99	4.93	7.46	9.31	10.86	12.28	

Notes: Higher back pressures can be provided by using internal vacuum supports and/or engineered Hi-Tensile reinforcement, contact PROCO.

1. Dimensions are approximate and may change due to pipe dimension changes, inlet, back pressures and flow rates.

2. Larger sizes available upon request.

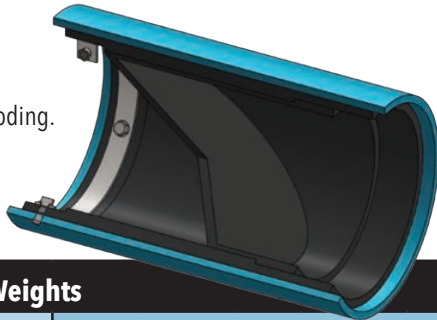
# PROCO STYLE 790

## ProFlex™ Low Headloss In-Line Rubber Check Valves



The **ProFlex™ 790** Low Headloss In-line Rubber Duckbill Check Valve design allows for a passive flow and allows the valve to be installed without having to do any modifications to existing structures or costly pre-install planning. The unique fold away design of the inner sleeve also allows for a near full port flow, allowing for quick drainage.

The **ProFlex™ 790** Low Headloss In-line Rubber Duckbill Check Valve is the valve of choice for municipalities, airport runway runoffs, railway washouts, highway flood damage prevention and odor control. The 790's unique design provides rapid dispersion of head pressures and with its low cracking pressure, it prevents upstream flooding.



The **ProFlex™ 790** Low Headloss In-line Rubber Duckbill Check Valve's ZERO backflow design, make it the perfect fit for:

- Combined Sewer Overflows (CSO'S):**  
 A combined sewer is a sewage collection system of pipe and tunnels designed to also collect surface runoff. Combined sewers can cause serious water pollution problems during combined sewer overflow (CSO) events when wet weather flows exceed the sewage treatment plant capacity.
- Sanitary Sewer Overflow:**  
 A condition in which untreated sewage is discharged from a sanitary sewer into the environment prior to reaching sewage treatment facilities.
- Outfalls:**  
 An outfall is the discharge point of a waste stream into a body of water; alternatively, it may be the outlet of a river, drain or a sewer where it discharges into a body of water.

**Table 11: Sizes • Weights**

NOMINAL 1 PIPE SIZE Valve I.D. Inch / (mm)	Internal Clamp(s)  #/Valve Segment	Standard Dimensions/Ratings for PROCO Style 790			WEIGHT 2 lbs / (kgs)	
		Cuff Width Inch / (mm)	Length Inch / (mm)	Backpressure Feet / (m)		
3	(80)	1 1	2.00 (38)	8 (204)	40 (12)	5 (2.27)
4	(100)	1 1	2.00 (38)	9 (229)	40 (12)	5 (2.27)
6	(150)	1 1	3.00 (51)	12 (305)	40 (12)	8 (3.63)
8	(200)	1 1	3.00 (51)	14 (356)	40 (12)	14 (6.36)
10	(250)	1 1	3.00 (51)	16 (407)	40 (12)	18 (8.17)
12	(300)	1 1	3.00 (51)	20 (508)	40 (12)	35 (15.88)
14	(350)	1 1	5.00 (102)	26 (661)	20 (6)	75 (34.02)
16	(400)	1 1	5.00 (102)	29 (737)	20 (6)	115 (52.17)
18	(450)	1 1	5.00 (102)	31 (788)	20 (6)	137 (62.15)
20	(500)	2 2	8.00 (203)	43 (1093)	20 (6)	210 (95.26)
24	(600)	2 2	8.00 (203)	48 (1220)	20 (6)	300 (136.08)
30	(750)	2 2	8.00 (203)	55 (1397)	20 (6)	476 (215.92)
36	(900)	2 2	8.00 (203)	63 (1601)	20 (6)	785 (356.08)
42	(1050)	2 2	8.00 (203)	71 (1804)	15 (5)	1350 (612.36)
48	(1200)	2 3	8.00 (203)	80 (2032)	15 (5)	1725 (782.46)
54	(1350)	2 3	8.00 (203)	87 (2210)	15 (5)	2500 (1134.00)
60	(1500)	2 3	12.00 (305)	103 (2617)	15 (5)	3225 (1462.86)
72	(1800)	3 3	12.00 (305)	127 (3226)	12 (4)	6650 (3016.43)



Notes: Higher back pressures can be provided by using internal vacuum supports and/or engineered Hi-Tensile reinforcement, contact PROCO.



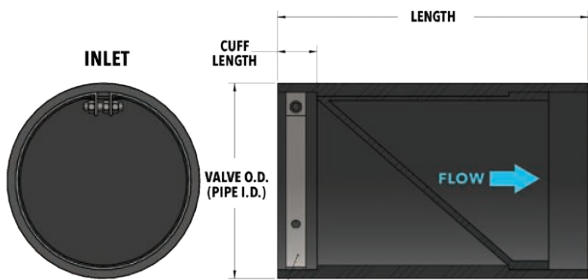


**Available Elastomers**  
 Neoprene (Barnacle and Algae Resistant),  
 NSF/ANSI Standard 61, EPDM, Nitrile,  
 Natural Rubber, CSM and Chlorobutyl.

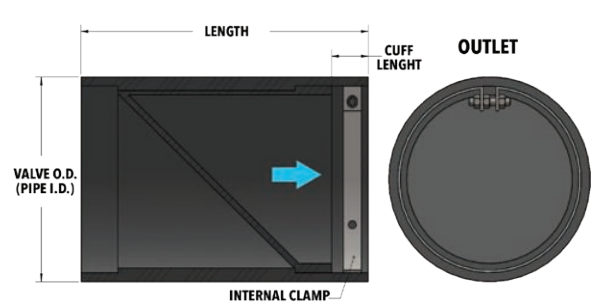


Detail of the *ProFlex™* Low Headloss In-line Rubber Check Valve; Style 790

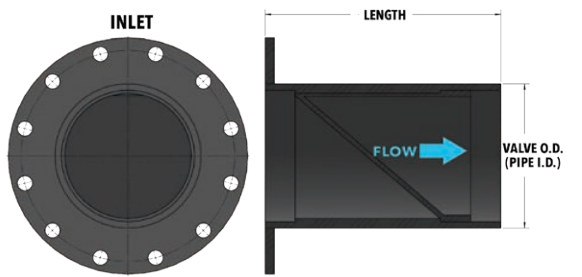
Upstream Clamp



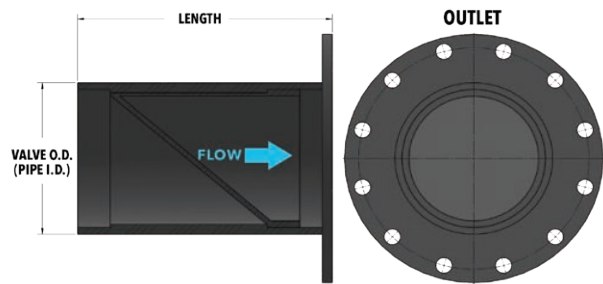
Downstream Clamp



Upstream Flanged



Downstream Flanged



# Frequently Asked Questions

## ProFlex™ Check Valves

### 1. Does the ProFlex™ rubber check valve have to be installed in a certain position?

Yes; it should be installed in a vertical position with the bill being the vertical. In zero clearance situations the valve can be rotated up to 30-35 Deg to gain bottom clearance if required.

### 2. In which degree can the ProFlex™ rubber check valve be installed?

Because the valve is not reliant on any hinges, gates, or weights the ProFlex™ rubber check valve can be installed in any angle from vertical to horizontal.

### 3. What is "Back Pressure"?

When the ProFlex™ rubber check valve is submerged in a liquid it is subjected to external pressure. It is critical that the maximum depth that the valve will be submerged is specified as this will be considered the maximum back pressure that the valve will be subjected to.

### 4. What is the cracking pressure to allow the valve to open?

1" to 2" of water column over back pressure will normally drain a pipe.

### 5. What back pressures can the ProFlex™ rubber check valve withstand?

Back pressures are in direct relation to the size of the valve, on the smaller diameters it is acceptable to specify up to 200 psi of back pressure and on larger diameters a back pressure limitation would be approximately 12 psi. Each ProFlex™ rubber check valve is manufactured to the exact line pressure, back pressure and flow rates which we require from you for manufacture. Proco can even supply valves up to 650 psi utilizing internal back pressure supports.

### 6. What are the most common installations?

The ProFlex™ 710 flanged rubber check valve is bolted directly to a head wall replacing an existing flap gate, the ProFlex™ 730 sleeved type rubber check valves are clamped directly to a fabricated flanged nipple or clamped directly to an existing pipe.

### 7. Can I use the ProFlex™ rubber check valve on potable water applications?

The ProFlex™ rubber check valves are available with an ANSI/NSF-61 certified elastomer. Due to the large demand for clean water and potable applications, this will eliminate the concerns commonly affiliated with contaminants or leaching of elastomers in potable water systems.

### 8. Can the ProFlex™ rubber check valve be installed on an "out of round" pipe?

Yes, please have the approximate dimensions from 4 different angles to provide proper sizing.

### 9. Can river currents and ocean waves damage the valves?

In most cases river currents and ocean waves will not damage the ProFlex™ rubber check valves, but if currents or waves in question are of an abnormal nature, it is suggested that side walls or rock pilings are utilized.

### 10. Can the ProFlex™ rubber check valve be used as a pressure relief valve?

The ProFlex™ rubber check valves have been designed to offer superior service as a backflow preventer and can also be considered as a pressure relief valve. Often used on reservoirs to prevent hydraulic lifting or floating of tanks.

### 12. What types of elastomer are available?

The ProFlex™ rubber check valves can be manufactured and supplied to withstand almost any type of media. Most commonly supplied is a barnacle and algae resistant Neoprene. Other common elastomers available are ANSI/NSF-61, ANSI/NSF-372 & EPDM. Contact Proco for other available elastomers.

### 13. What types of materials are available for the backing rings and banding clamps?

ProFlex™ rubber check valves are supplied with 316 stainless steel backing rings and 304 stainless steel clamps as a standard. Other materials are available upon request.

### 14. Can the ProFlex™ 710 be supplied with special flanges or drilling?

Yes, the standard drilling pattern is ANSI 125/150# drilling, other drilling standards such as: ANSI 250/300#, BS-10, DIN NP-10 and DIN NP-16, JIS-5k and JIS-10K are available upon special request.

### 15. Can I install a ProFlex™ rubber check valve near a residential area?

Yes, one of the unique features of the ProFlex™ rubber check valve is the design of the bill section. While the bill will open and allow passage of fluid when head pressure is present, the bill will close and not allow children or animals to crawl inside when there is no head pressure.

Since the ProFlex™ rubber check valve is manufactured entirely of rubber compounds there is no chance of loud banging which is commonly heard from flap type valves.

### 16. Can I use a ProFlex™ rubber check valve in winter conditions?

Yes, as in any installation the ProFlex™ rubber check valve will not be hindered by winter or sub-zero installations. If the valve is installed in a running water application the valve will continue to operate satisfactorily, due to the elastomers unique chemical makeup. If unusual circumstances occur the ProFlex™ rubber check valve will freeze without any damage and will return to operation upon thaw.

### 17. Will the ProFlex™ rubber check valve operate if buried in sand or sediment?

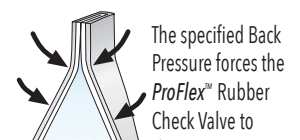
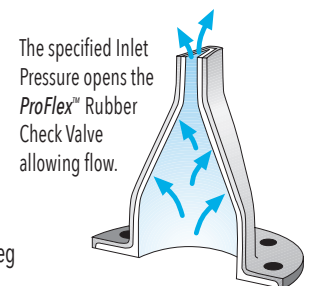
In normal conditions the discharge flow will create a small flow pattern which will then be followed by the flow velocity of the media. This velocity will flush the rest of the sediment away from the valve opening. This has been found to be unique only to the straight bill design as supplied by Proco.

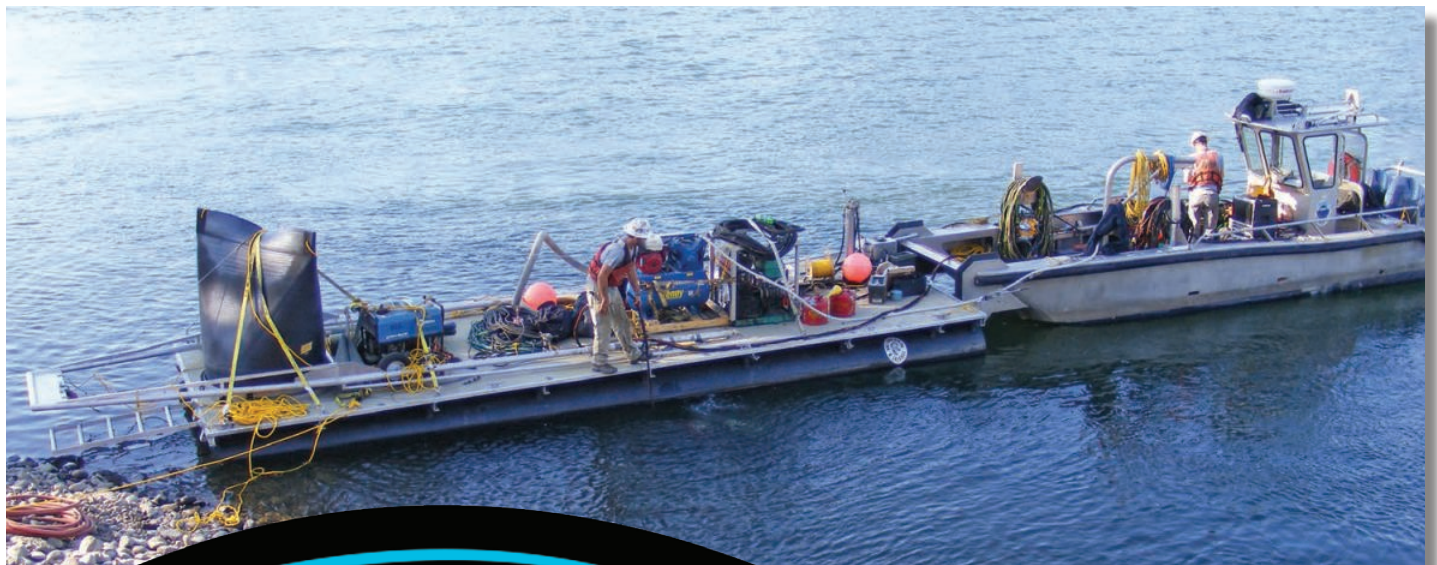
### 18. What is the maximum temperature that the ProFlex™ rubber check valve can handle?

Temperature can range from -65 Deg to +400 Deg depending on the specified elastomer.

### 19. What is the life expectancy of the ProFlex™ Rubber check valves?

All of the ProFlex™ valves are manufactured with the highest grade of elastomers, which commonly





**GOODYEAR**  
RUBBER PRODUCTS, INC.

727-342-5088

You can also email us at  
[GRP@goodyearrubberproducts.com](mailto:GRP@goodyearrubberproducts.com)



2431 North Wigwam Dr. (95205)  
P.O. Box 590 • Stockton, CA  
95201-0590 • USA

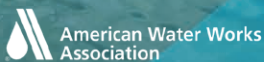
Toll-Free Phone: (800) 344-3246

Facsimile: (209) 943-0242

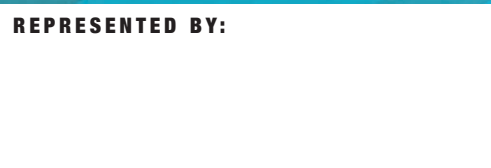
(209) 943-6088

**NATIONWIDE AND CANADA**

**INTERNATIONAL**



**REPRESENTED BY:**



**GOODYEAR**  
RUBBER PRODUCTS, INC.

**727-342-5088**

You can also email us at  
**GRP@goodyearrubberproducts.com**