



Catalog 3900 USA



April 2017

Quick Coupling Products

You can also email us at  
[GRP@goodyearrubberproducts.com](mailto:GRP@goodyearrubberproducts.com)

## Quick Coupling Division Locations



Minneapolis, MN



Grantsburg, WI



Chetek, WI



Union City, PA

### **WARNING**

#### **FAILURE OR IMPROPER SELECTION OR IMPROPER USE OF THE PRODUCTS DESCRIBED HEREIN OR RELATED ITEMS CAN CAUSE DEATH, PERSONAL INJURY AND PROPERTY DAMAGE.**

- This document and other information from Parker-Hannifin Corporation, its subsidiaries and authorized distributors provide product or system options for further investigation by users having technical expertise.
- The user, through its own analysis and testing, is solely responsible for making the final selection of the system and components and assuring that all performance, endurance, maintenance, safety and warning requirements of the application are met. The user must analyze all aspects of the application, follow applicable industry standards, and follow the information concerning the product in the current product catalog and in any other materials provided from Parker or its subsidiaries or authorized distributors.
- To the extent that Parker or its subsidiaries or authorized distributors provide component or system options based upon data or specifications provided by the user, the user is responsible for determining that such data and specifications are suitable and sufficient for all applications and reasonably foreseeable uses of the components or systems.



#### **Dave Reede Photo**

111 Breakwater Cove  
Winnipeg, MB R3X 1G3

Phone: 204 553 7445

E-Mail: [dave@davereedphoto.mb.ca](mailto:dave@davereedphoto.mb.ca)

[www.davereedphoto.mb.ca](http://www.davereedphoto.mb.ca)

The excellent agricultural photography in this Pioneer catalog has been provided and authorized by Canadian photographer Dave Reede.

Dave is a stock and assignment photographer. Although he photographs a variety of subject matter, he is well known for his images of agriculture and farm life. He has been passionately photographing agriculture since 1986 when he arrived on the Canadian Prairies. Dave has been documenting some farm operations for the past twenty years. His unique style of agriculture photography is sought after by many of North America's well-known companies and organizations in the agriculture sector. His agriculture imagery is also used world-wide on an ongoing basis, for uses ranging from editorial to major advertising campaigns. Dave is also an accomplished photographer of the landscape and outdoor recreation.

Whether riding on top of a combine to get a different view, shooting from a variety of stepladders, or diving out of the way of an oncoming combine, Dave creates images with creativity and impact. Over the years Dave has worked diligently to get a unique, in-depth coverage of all aspects of prairie agriculture, including farm life, crops, equipment, harvest, chemical application, agricultural landscapes and farmers.

Thanks Dave for your s

**GOODYEAR**  
RUBBER PRODUCTS, INC.

 **727-342-5088**



## Table of Contents

Quick Couplings.....	Section A
Flow Control/Check Valves.....	Section B
Diagnostic Equipment.....	Section C
Appendix.....	Section D



# Quick Couplings

Pioneer has been “The Farmer’s Choice” for more than 60 years, and it is the world leader in quick coupling products for the agricultural industry.

These products are manufactured in state-of-the-art manufacturing plants using the latest technologies to provide you with products of the highest quality and durability.

Pioneer offers the widest range of quick couplings on the market, and has a product for nearly every agricultural application.

## Agricultural Couplings and Accessories

- 8010 Series.....A-2
- 4000 Series.....A-3
- 4200 Series.....A-6
- 6600 Series.....A-8
- 8200 Series.....A-11
- 8450 Series.....A-13
- 9200 Series.....A-14
- 9500 Series.....A-17
- 5000 Series.....A-18
- Clamps.....A-20
- Agricultural QC Adapters.....A-21
- Original Equipment Products.....A-23
- OEM Aftermarket.....A-25
- Retail Products.....A-28

## Hydraulic Couplings

- 3000 Series.....A-34
- FF/FC Series.....A-36
- FEM/FEC Series.....A-40
- EAS/SAE Adapters.....A-44
- FS Series.....A-45
- PF Series.....A-48
- ST Series.....A-50
- 1163 Series.....A-53

## Pneumatic Couplings

- Pneumatic Industrial Interchange Nipples.....A-54
- 20 Series.....A-57
- RF Series.....A-60
- HF Series.....A-63
- UC Series (Universal).....A-67
- E-z-mate Series.....A-68



The 8010 Series is the standard male tip of the agricultural industry, developed and proven by Pioneer in over 60 years of farm service. These nipples will connect with all 1/2" body size 4000, 4200, 5000, 6600, 8200, 8450, and 9200 series couplers. Tips are offered in three valve styles; ball, poppet, and DC (connect under pressure) poppet. The DC version allows connection under system pressure on the coupler side and residual pressure (up to 3000 psi) on the nipple side.

### Features:

- Conforms to ISO 5675 requirements
- DC poppet style offers connect under pressure option
- Poppet style valve prevents uncoupled leakage of hydraulic fluid
- Hardened locking ball groove prevents Brinelling
- Shielded valve and positive valve stop eliminates flow checking
- Protective zinc plating with clear trivalent chromate finish

### Applications include:

- Tractors
- Implements
- Agricultural attachments

8010 Series Universal Nipple							
Body Size	Nipple Part Number	Port End	Valve Type	Length	Largest Diameter	Wrench Flats	Weight (lbs.)
1/2	8010-4	1/2-14 NPTF	Ball	1.95	1.23	1.06	0.20
1/2	8010-4P	1/2-14 NPTF	Poppet	1.95	1.23	1.06	0.20
1/2	8010-5	3/4-14 NPTF	Ball	2.14	1.44	1.25	0.25
1/2	8010-5P	3/4-14 NPTF	Poppet	2.14	1.44	1.25	0.25
1/2	8010-15	3/4-16 ORB	Ball	1.95	1.23	1.06	0.20
1/2	8010-15P	3/4-16 ORB	Poppet	1.95	1.23	1.06	0.20
1/2	8010-16	7/8-14 ORB	Ball	1.95	1.23	1.06	0.25
1/2	8010-16P	7/8-14 ORB	Poppet	1.95	1.23	1.06	0.25
1/2	8010-20PM	M22 X 1.5	Poppet	2.14	1.23	1.06	0.25
1/2	8010-29BSPP	1/2-14 BSPP	Ball	1.95	1.18	1.06	0.25

8010 Series Connect-Under-Pressure Nipple*							
Body Size	Nipple Part Number	Port End	Valve Type	Length	Largest Diameter	Wrench Flats	Weight (lbs.)
1/2	8010-4P-DC	1/2-14 NPTF	Poppet	1.95	1.23	1.06	0.20
1/2	8010-15P-DC	3/4-16 O-Ring Boss	Poppet	1.95	1.23	1.06	0.25

\* Not for use with 9200 Series Couplers

8010 Series Specifications				
Body Size	Rated Flow	Rated Pressure	Temperature	Poppet Seal Material
1/2	12 gpm	3000 psi	-40° F to +250° F	Nitrile

8010 Series Dust Cap			
Body Size	Dust Cap	Color/Material	Weight (lbs.)
1/2	5209-4M	Black Rubber	.04
1/2	5209-4M-BU	Blue Rubber	.04
1/2	5209-4M-GR	Green Rubber	.04
1/2	5209-4M-RE	Red Rubber	.04
1/2	5209-4M-YE	Yellow Rubber	.04





The 4000 Series brings to the industry a proven design for use on agricultural machinery and other rugged applications.

**Features:**

- Accepts ISO 5675 universal tips
- Basic operation where coupler sleeve is manually retracted to allow connection with male tip
- Critical parts are induction hardened
- Ball and poppet valve options
- Protective zinc plating with clear trivalent chromate finish

**Applications include:**

- Hydraulic Loaders
- Add-on hydraulic circuits
- Hydraulic tools
- Snow plow attachments

4000 Series Specifications:						
Body Size	Rated Flow (gpm)	Rated Pressure (psi)	Temperature	Body Material	Sleeve Type	Seal Material
1/4	3	3000	-40° F to +250° F	Steel	Manual Connect	Nitrile
3/8	6					
1/2	12					
3/4	28					
1	50					

**Performance:**

4000 Series (1/4", 3/8", 1/2")  
Test Fluid: Oil - 200 SUS

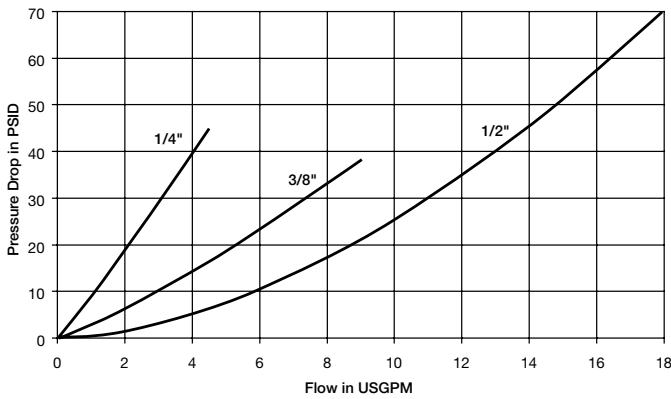

4000 Series (3/4" & 1")  
Test Fluid: Oil - 200 SUS

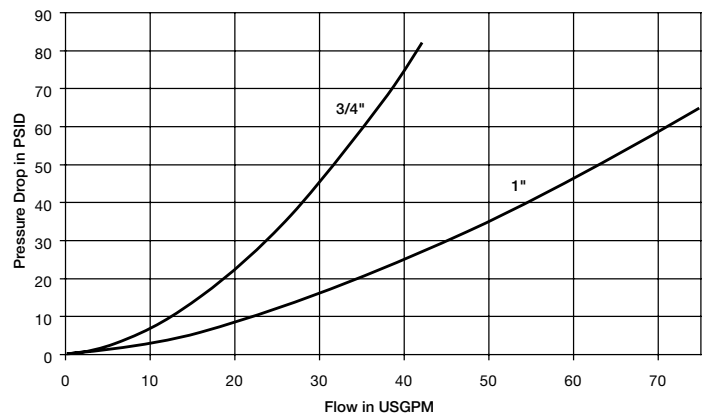



### 4000 Series Couplers



Body Size	Coupler Part Number	Port End	Valve Type	Length	Largest Diameter	Wrench Flats	Weight (lbs.)	Complete Coupling Part Number
1/4	4050-2P	1/4-18 NPTF	Poppet	2.18	1.06	0.88	0.24	4000-2P
1/4	4050-2P-T8M	3/4-16 ORB (Male)	Poppet	1.80	1.06	0.88	0.21	-
1/4	4050-T6	9/16-18 ORB	Poppet	2.18	1.06	0.88	0.27	-
1/4	4050P-T6*	9/16-18 ORB	Poppet	2.43	1.33	0.88	0.33	-
3/8	4050-3P	3/8-18 NPTF	Poppet	2.31	1.33	0.94	0.51	4000-3P
1/2	4050-4	1/2-14 NPTF	Ball	2.60	1.50	1.06	0.58	4000-4
1/2	4050-4P	1/2-14 NPTF	Poppet	2.60	1.50	1.06	0.58	4000-4P
1/2	4050-5	3/4-14 NPTF	Ball	2.69	1.50	1.13	0.71	4000-5
1/2	4050-5P	3/4-14 NPTF	Poppet	2.69	1.50	1.13	0.71	4000-5P
1/2	4050-15	3/4-16 ORB	Ball	2.81	1.50	1.06	0.64	4000-15
1/2	4050-15P	3/4-16 ORB	Poppet	2.81	1.50	1.06	0.64	4000-15P
1/2	4050-16	7/8-14 ORB	Ball	2.75	1.50	1.06	0.59	4000-16
1/2	4050-16P	7/8-14 ORB	Poppet	2.75	1.50	1.06	0.59	4000-16P
1/2	4050-29BSPP	1/2-14 BSPP	Ball	2.68	1.50	1.06	0.59	-
3/4	4150-5	3/4-14 NPTF	Ball	3.06	1.87	1.38	1.00	4100-5
1	4050-6P	1-11 1/2 NPTF	Poppet	3.84	2.08	1.63	1.89	4000-6P

\* Special Push/Pull Sleeve

### 8010 Series Nipples



Poppet Ball Valve



See page A-2 for additional ISO 5675 tip options.

Body Size	Nipple Part Number	Port End	Valve Type	Length	Largest Diameter	Wrench Flats	Weight (lbs.)	Complete Coupling Part Number
1/4	4010-2P	1/4-18 NPTF	Poppet	1.48	0.87	0.75	0.08	4000-2P
1/4	4010-T6	9/16-18 ORB	Poppet	1.60	0.87	0.75	0.09	-
3/8	4010-3P	3/8-18 NPTF	Poppet	1.60	1.08	0.94	0.16	4000-3P
1/2	8010-4	1/2-14 NPTF	Ball	1.95	1.23	1.06	0.20	4000-4
1/2	8010-4P	1/2-14 NPTF	Poppet	1.95	1.23	1.06	0.20	4000-4P
1/2	8010-5	3/4-14 NPTF	Ball	2.14	1.44	1.25	0.25	4000-5
1/2	8010-5P	3/4-14 NPTF	Poppet	2.14	1.44	1.25	0.25	4000-5P
1/2	8010-15	3/4-16 ORB	Ball	1.95	1.23	1.06	0.20	4000-15
1/2	8010-15P	3/4-16 ORB	Poppet	1.95	1.23	1.06	0.20	4000-15P
1/2	8010-16	7/8-14 ORB	Ball	1.95	1.23	1.06	0.25	4000-16
1/2	8010-16P	7/8-14 ORB	Poppet	1.95	1.23	1.06	0.25	4000-16P
1/2	8010-29BSPP	1/2-14 BSPP	Ball	1.95	1.18	1.06	0.25	-
3/4	4110-5	3/4-14 NPTF	Ball	1.81	1.52	1.31	0.50	4100-5
1	4010-6P	1-11 1/2 NPTF	Poppet	2.79	1.88	1.63	0.62	4000-6P

1/8"

1/4"

3/8"

1/2"

5/8"

3/4"

1"

1-1/4"

1-1/2"



### 4050 Series Replacement O-Rings

Body Size	Material	Part Number	Durometer
1/4	Nitrile	50001-113-0260	90
3/8	Nitrile	50001-116-0260	90
1/2	Nitrile	50001-211-0260	90
3/4	Nitrile	50001-215-0010	70
1	Nitrile	50001-218-0260	90

### 4000 Series Dust Plugs and Caps



Body Size	Dust Plug	Color/Material	Dust Cap	Weight (lbs.)
1/4	5205-2M	Black Rubber	5209-2M	.02
3/8	5205-3M	Black Rubber	5209-3M	.03
1/2	5205-4M	Black Rubber	5209-4M	.04
1/2	5205-4M-BU	Blue Rubber	5209-4M-BU	.04
1/2	5205-4M-GR	Green Rubber	5209-4M-GR	.04
1/2	5205-4M-RE	Red Rubber	5209-4M-RE	.04
1/2	5205-4M-YE	Yellow Rubber	5205-4M-YE	.04
1/2	5005-4	Steel w/Chain	5009-4	.21
3/4	5205-5M	Black Rubber	5209-5M	.05
1	5205-6M	Black Rubber	5209-6M	.06

Quick Couplings





The 4200 Series brings to the industry a proven design for use on agricultural machinery and other rugged applications where a breakaway feature is desirable.

### Features:

- Accepts ISO 5675 universal tips
- Grooves in sleeve to accommodate retaining rings for bulkhead mounting
- One-handed push-to-connect operation when coupler is clamp mounted
- 1/2" body size couplers are compatible with 5001-4 and 5006-4 breakaway clamps
- Critical parts are induction hardened
- Ball and poppet valve options
- Protective zinc plating with clear trivalent chromate finish

### Applications include:

- Hydraulic Loaders
- Add-on hydraulic circuits
- Implement breakaway
- Hydraulic tools



4200 Series Specifications:						
Body Size	Rated Flow (gpm)	Rated Pressure (psi)	Temperature	Body Material	Sleeve Type	Seal Material
3/8	6	3000	-40° F to +250° F	Steel	Push/Pull/ Breakaway	Nitrile
1/2	12					

### Performance:

4200 Series (3/8" & 1/2")  
Test Fluid: Oil - 200 SUS

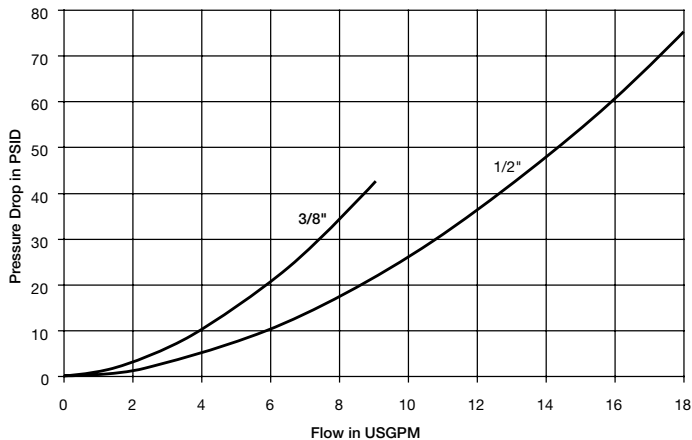



4200 Series Couplers



Body Size	Coupler Part Number	Port End	Valve Type	Length	Largest Diameter	Wrench Flats	Weight (lbs.)	Complete Coupling Part Number
3/8	4250-3P	3/8-18 NPTF	Poppet	2.31	1.31	0.81	0.39	4200-3P
1/2	4250-4	1/2-14 NPTF	Ball	2.68	1.50	0.94	0.55	4200-4
1/2	4250-4P	1/2-14 NPTF	Poppet	2.68	1.50	0.94	0.55	4200-4P
1/2	4250-15	3/4-16 ORB	Ball	2.68	1.50	0.94	0.55	4200-15
1/2	4250-15P	3/4-16 ORB	Poppet	2.68	1.50	0.94	0.55	4200-15P

8010 Series Nipples



Poppet Ball Valve



See page A-2 for additional ISO 5675 tip options.

Body Size	Nipple Part Number	Port End	Valve Type	Length	Largest Diameter	Wrench Flats	Weight (lbs.)	Complete Coupling Part Number
3/8	4010-3P	3/8-18 NPTF	Poppet	1.60	1.08	0.94	0.16	4200-3P
1/2	8010-4	1/2-14 NPTF	Ball	1.95	1.23	1.06	0.20	4200-4
1/2	8010-4P	1/2-14 NPTF	Poppet	1.95	1.23	1.06	0.20	4200-4P
1/2	8010-15	3/4-16 ORB	Ball	2.06	1.23	1.06	0.20	4200-15
1/2	8010-15P	3/4-16 ORB	Poppet	2.06	1.23	1.06	0.20	4200-15P

4200 Series Accessories



Body Size	Part Number	Clamp Type	Weight (lbs.)
1/2	5001-4	Single	.66
1/2	5006-4	Double	.81

4200 Series Dust Plugs and Caps



Body Size	Dust Plug	Color/Material	Dust Cap	Weight (lbs.)
3/8	5205-3M	Black Rubber	5209-3M	.03
1/2	5205-4M	Black Rubber	5209-4M	.04
1/2	5205-4M-BU	Blue Rubber	5209-4M-BU	.04
1/2	5205-4M-GR	Green Rubber	5209-4M-GR	.04
1/2	5205-4M-RE	Red Rubber	5209-4M-RE	.04
1/2	5205-4M-YE	Yellow Rubber	5205-4M-YE	.04
1/2	5005-4	Steel w/Chain	5009-4	.21

4250 Series Replacement O-Rings

Body Size	Material	Part Number	Durometer
3/8	Nitrile	50001-116-0260	90
1/2	Nitrile	50001-211-0260	90



The 6600 Series are versatile for use in a wide range of hydraulic applications where fluid lines require connection and disconnection for equipment operation or maintenance

### Features:

- Accepts ISO 7241-1, Series A compliant nipples
- Poppet valves and a metal perch to maintain valve alignment and prevent flow checking
- Coupler sleeve and nipple body are hardened to be damage resistant
- Standard end configurations include female pipe and straight thread ORB
- Protective zinc plating with clear trivalent chromate finish

### Applications include:

- Snow plows
- Truck trailer connections
- Mobile applications
- Attachments

6600 Series Specifications:						
Body Size	Rated Flow (gpm)	Rated Pressure (psi)	Temperature	Body Material	Sleeve Type	Seal Material
1/4	0.8	5000	-40° F to +250° F	Steel	Manual Connect	Nitrile
3/8	6	4000				
1/2	12	4000				
3/4	28	4000				
1	50	4000				

### Performance:

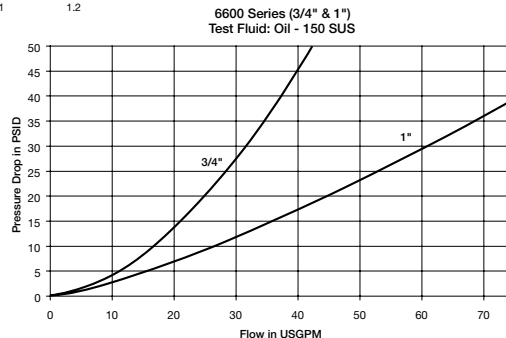
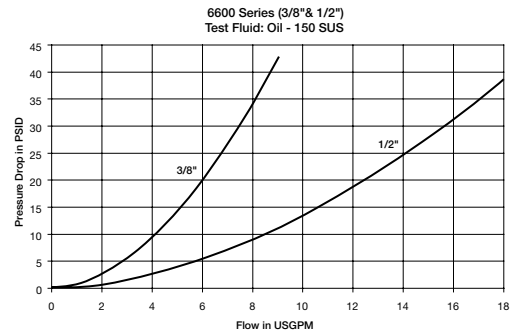
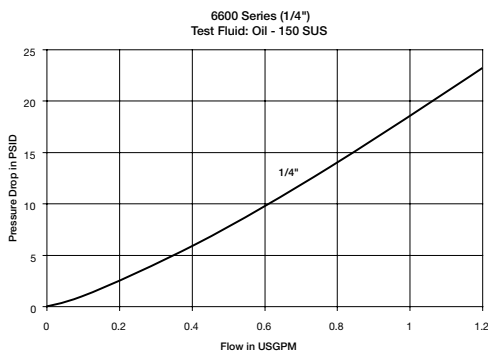



6600 Series Couplers



Body Size	Coupler Part Number	Port End	Valve Type	Length	Largest Diameter	Wrench Flats	Weight (lbs.)
1/4	6601-2-4	1/8 -27 NPTF	Poppet	1.85	1.08	0.88	0.27
1/4	6601-4-4	1/4 -18 NPTF	Poppet	1.85	1.08	0.88	0.26
3/8	6601-6-6	3/8 -18 NPTF	Poppet	2.18	1.27	1.06	0.39
3/8	6608-6-6	9/16 -18 ORB	Poppet	2.18	1.27	1.06	0.38
1/2	6601-8-10	1/2 -14 NPTF	Poppet	2.75	1.52	1.25	0.67
1/2	6601-12-10	3/4 -14 NPTF	Poppet	2.88	1.52	1.38	0.71
1/2	6608-8-10	3/4 -16 ORB	Poppet	2.74	1.52	1.25	0.67
1/2	6608-10-10	7/8 -14 ORB	Poppet	2.79	1.52	1.25	0.64
1/2	6608-12-10	1 1/16 -12 ORB	Poppet	3.01	1.52	1.38	0.77
3/4	6601-12-12	3/4 -14 NPTF	Poppet	3.36	1.90	1.62	1.31
3/4	6608-12-12	1 1/16 -12 ORB	Poppet	3.35	1.90	1.62	1.31
1	6601-16-16	1-11 1/2 NPTF	Poppet	4.11	2.14	1.88	1.93
1	6608-16-16	1 5/16 -12 ORB	Poppet	4.11	2.14	1.88	1.75

6600 Series Nipples



Body Size	Nipple Part Number	Port End	Valve Type	Length	Largest Diameter	Wrench Flats	Weight (lbs.)
1/4	6602-2-4	1/8 -27 NPTF	Poppet	1.41	0.65	0.56	0.05
1/4	6602-4-4	1/4 -18 NPTF	Poppet	1.41	0.87	0.75	0.07
3/8	6602-6-6	3/8 -18 NPTF	Poppet	1.63	1.01	0.88	0.11
3/8	6610-6-6	9/16 -18 ORB	Poppet	1.63	1.01	0.88	0.13
1/2	6602-8-10	1/2 -14 NPTF	Poppet	2.08	1.23	1.06	0.21
1/2	6602-12-10	3/4 -14 NPTF	Poppet	2.30	1.59	1.38	0.33
1/2	6610-8-10	3/4 -16 ORB	Poppet	2.08	1.23	1.06	0.22
1/2	6610-10-10	7/8 -14 ORB	Poppet	2.08	1.30	1.12	0.21
1/2	6610-12-10	1 1/16 -12 ORB	Poppet	2.30	1.59	1.38	0.33
3/4	6602-12-12	3/4 -14 NPTF	Poppet	2.55	1.59	1.38	0.49
3/4	6610-12-12	1 1/16 -12 ORB	Poppet	2.55	1.59	1.38	0.47
1	6602-16-16	1-11 1/2 NPTF	Poppet	3.10	1.88	1.62	0.75
1	6610-16-16	1 5/16 -12 ORB	Poppet	3.10	2.17	2.08	0.72

6600 Series Replacement Parts

	1/4	3/8	1/2	3/4	1
O-Rings - Nitrile	50001-112-0010	50001-115-0010	50001-211-0010	50001-123-0010	50001-126-0010
Back-up Rings	4118006	4118005	50-140-4	4138001	4148002



**6600 Series Dust Caps and Plugs**



Body Size	Dust Plug (Coupler)	Color/Material	Dust Cap (Nipple)	Weight (lbs.)
1/4	H1-65M	Black Rubber	H1-66M	.02
3/8	TR-37	Black Rubber	TR-37	.04
1/2	5205-4M	Black Rubber	5209-4M	.04
3/4	6659-12M	Black Rubber	6657-12M	.06
1	6659-16M	Black Rubber	6657-16M	.08





Pioneer's 8200 Series unique valve design allows connection while either or both the coupler and nipple are under pressure. Valves in both halves remain closed, opening only when system pressure has been relieved on the female body and then reapplied. This pressure sequence may be done with either an open center or a closed center hydraulic system that has a control valve.

### Features:

- Accepts ISO 5675 universal tips
- Connect under system pressure on the coupler side and residual pressure on the nipple side
- Sleeve designed to accommodate bracket mounting
- One-handed push-to-connect operation when coupler is clamp mounted
- 1/2" body size couplers are compatible with 5001-4 and 5006-4 breakaway clamps
- Critical parts are induction hardened
- Protective zinc plating with clear trivalent chromate finish

### Applications include:

- Tractors
- Mid-sized agricultural equipment
- Agricultural attachments requiring breakaway



### 8200 Series Specifications

Body Size	Rated Flow	Rated Pressure	Temperature	Body Material	Sleeve Type	Seal Material
1/2	12 gpm	3000 psi	-40° F to +250° F	Steel	Push-pull/break away	Nitrile



### Performance

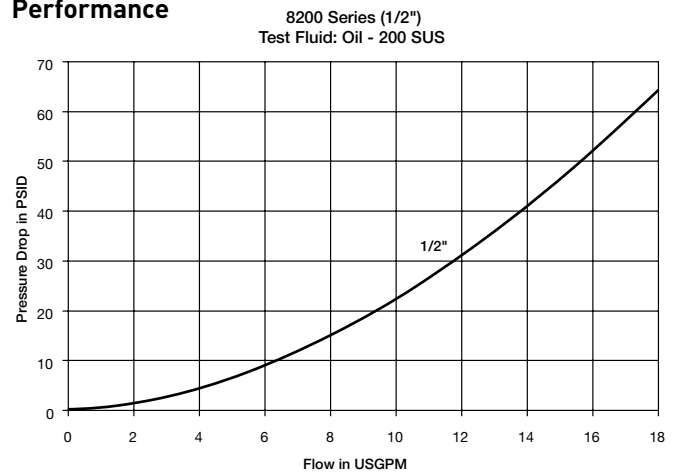



### 8200 Series Couplers - Female Thread



Body Size	Coupler Part Number	Port End	Valve Type	Length	Largest Diameter	Wrench Flats	Weight (lbs.)	Complete Coupling Part Number
1/2	8250-4	1/2-14 NPSF	Poppet	3.29	1.50	0.87	0.63	8200-4
1/2	8250-15	3/4-16 ORB	Poppet	3.29	1.50	0.87	0.63	8200-15
1/2	8250-16	7/8-14 ORB	Poppet	3.29	1.50	0.87	0.63	8200-16

### 8010 Series Nipples - Female Thread



See page A-2 for additional ISO 5675 tip options.

Body Size	Coupler Part Number	Port End	Valve Type	Length	Largest Diameter	Wrench Flats	Weight (lbs.)	Complete Coupling Part Number
1/2	8010-4	1/2-14 NPTF	Ball	1.95	1.23	1.06	0.20	8200-4
1/2	8010-4P	1/2-14 NPTF	Poppet	1.95	1.23	1.06	0.20	-
1/2	8010-15	3/4-16 ORB	Ball	1.95	1.23	1.06	0.20	8200-15
1/2	8010-15P	3/4-16 ORB	Poppet	1.95	1.23	1.06	0.20	-
1/2	8010-16	7/8-14 ORB	Ball	1.95	1.23	1.06	0.25	8200-16
1/2	8010-16P	7/8-14 ORB	Poppet	1.95	1.23	1.06	0.25	-

### 8200 Series Replacement Parts

Body Size	Part Number	Description	Material
1/2	50005-211-0200	O-Ring	Nitrile

### 8200 Series Dust Caps and Plugs



Body Size	Dust Plug (Coupler)	Color/Material	Dust Cap (Nipple)	Weight (lbs.)
1/2	5205-4M	Black Rubber	5209-4M	.04
1/2	5205-4	Steel w/Chain	5209-4	.21
1/2	5205-4M-BU	Blue Rubber	5209-4M-BU	.04
1/2	5205-4M-GR	Green Rubber	5209-4M-GR	.04
1/2	5205-4M-RE	Red Rubber	5205-4M-RE	.04
1/2	5005-4M-YE	Yellow Rubber	5009-4M-YE	.04

1/8"

1/4"

3/8"

1/2"

5/8"

3/4"

1"

1-1/4"

1-1/2"



reapplied. This pressure sequence may be done with either an open center or a closed center hydraulic system that has a control valve. The enclosed outer housing allows all connecting motion to be internal thereby preventing dust and dirt build-up around the sleeve mechanism. Suitable for rigid mount or use with a breakaway clamp.

### Features:

- Accepts ISO 5675 universal tips
- Straight thread ORB fitting end allows direct mounting to a control valve or rigid tubing
- Outer housing keeps dust and dirt away from the sleeve mechanism
- Connect under system pressure on the coupler side and on the nipple side
- One-handed push-to-connect operation when coupler is clamp or rigid mounted
- Couplers are compatible with 5006-4 breakaway clamps
- Protective zinc plating with clear trivalent chromate finish

Pioneer's 8450 Series unique valve design allows connection while either or both the coupler and nipple are under pressure. Valves in both halves remain closed, opening only when system pressure has been relieved on the female body and then

### Applications include:

- Tractors
- Mid-sized agricultural equipment

### 8450 Series Specifications

Body Size	Rated Flow	Rated Pressure	Temperature	Body Material	Sleeve Type	Seal Material
1/2"	12 gpm	3000 psi	-40° F to +250° F	Steel	Rigid Mount	Nitrile
<b>Connect Force</b>			<b>Disconnect Force</b>			
70 lbs. max at 0 psi		100 lbs. max at 3000 psi	40 lbs. min at 0 psi		165 lbs. max at 3000 psi	

### 8450 Series Couplers



Body Size	Coupler Part Number	Port End	Valve Type	Flats	Sleeve Diameter	Clamp to Use	Dust Plug
1/2	8450-16	7/8-14 ORB (Female)	Poppet	1.38	1.50	5006-4	8405-4 or 8407-4
1/2	8450-16M	7/8-14 ORB (Male)	Poppet	1.38	1.50	5006-4	8405-4 or 8407-4

### 8010 Series Nipples



Poppet



Ball Valve

[See page A-2 for additional ISO 5675 tip options.](#)

Body Size	Coupler Part Number	Port End	Valve Type	Length	Largest Diameter	Wrench Flats	Weight (lbs.)
1/2	8010-16	7/8-14 ORB (Female)	Ball	1.95	1.23	1.06	0.25
1/2	8010-16P	7/8-14 ORB (Female)	Poppet	1.95	1.23	1.06	0.25

### 8450 Series Dust Caps and Plugs



Dust Cap for Nipple	5209-4M
Dust Cover for Coupler	8511-022 Automatic
Dust Plug for Coupler	8512-030 Standard



The 9200 Series coupler allows zero pressure connection and disconnection while either or both the coupler and nipple are under pressure. A lever operated cam locks both coupler and nipple valves in the open or closed position. "Closed", the flow is shut off at the coupler, allowing easy, zero pressure connect and disconnect. Valves in the "Open" position are locked in place and unaffected by hydraulic surges. Valves will automatically close if the coupling is accidentally disconnected.

### Features:

- Accepts ISO 5675 universal tips
- Premier connect under pressure coupling
- Locked valves prevent flow checking
- Color coded levers to identify raise and lower lines
- Couplers are compatible with 9006-4 double breakaway clamp
- Protective zinc plating with clear trivalent chromate finish

### Applications include:

- Tractors
- Implements
- Agricultural attachments requiring breakaway

9200 Series Specifications:						
Body Size	Rated Flow	Rated Pressure	Temperature	Body Material	Sleeve Type	Seal Material
1/2	12 gpm	3000 psi	-40° F to +250° F	Steel	Double Acting	Nitrile

### Performance:

9200 Series (1/2")  
Test Fluid: Oil - 200 SUS

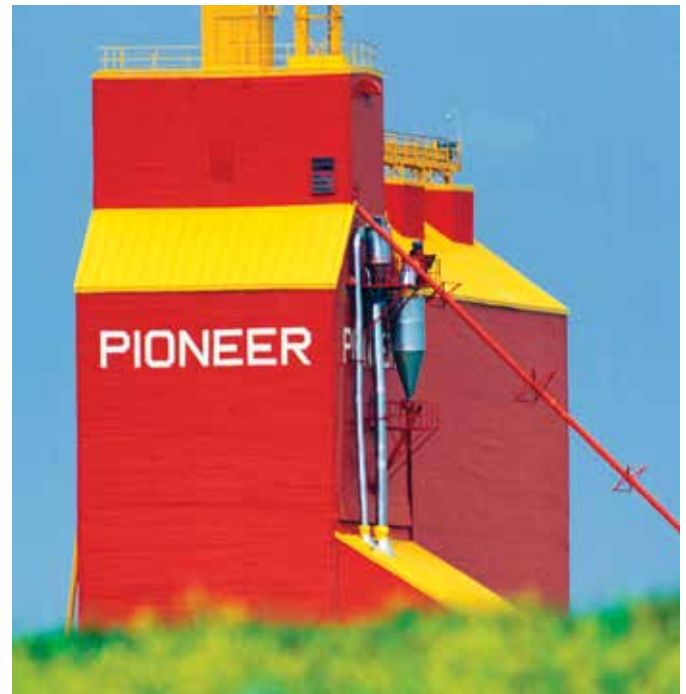
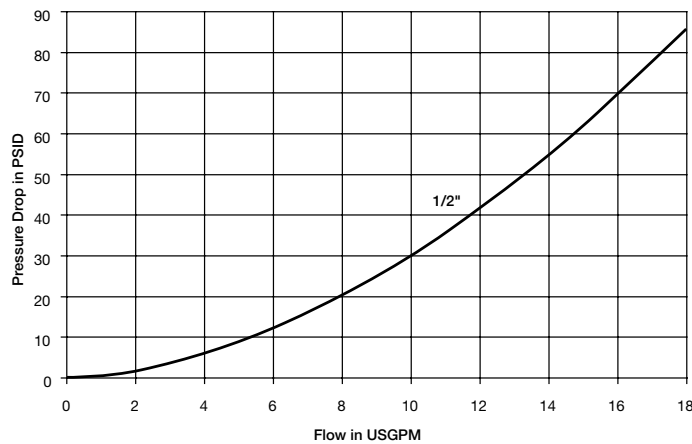



9200 Series Couplers

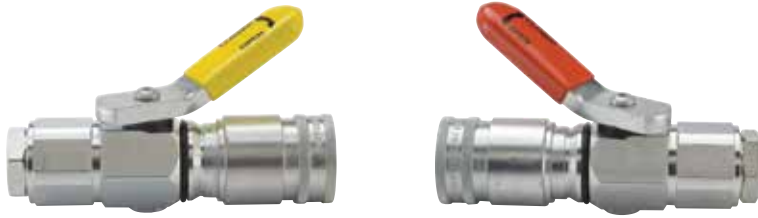

Body Size	Coupler Part Number	Port End	Valve Type	Orientation	Length	Largest Diameter	Wrench Flats	Weight (lbs.)
1/2	9250-4L	1/2-14 NPTF	Poppet	Left hand – yellow grip	5.37	1.50	1.13	2.02
1/2	9250-4L-UPC (bar coded for retail)	1/2-14 NPTF	Poppet	Left hand – yellow grip	5.37	1.50	1.13	1.92
1/2	9250-4R	1/2-14 NPTF	Poppet	Right hand – red grip	5.37	1.50	1.13	1.92
1/2	9250-4R-UPC (bar coded for retail)	1/2-14 NPTF	Poppet	Right hand – red grip	5.37	1.50	1.13	1.95
1/2	9250-4-320*	1/2-14 NPTF	Poppet	Left hand – yellow grip	5.37	1.50	1.13	1.98
1/2	9250-6-320*	9/16-18 UNF	Poppet	Left hand – yellow grip	5.37	1.50	1.13	2.06
1/2	9250-15L	3/4-16 UNF	Poppet	Left hand – yellow grip	5.37	1.50	1.13	1.92
1/2	9250-15R	3/4-16 UNF	Poppet	Right hand – red grip	5.37	1.50	1.13	1.92
1/2	9250-15-320*	3/4-16 UNF	Poppet	Left hand – yellow grip	5.37	1.50	1.13	2.06
1/2	9250-16L	7/8-14 UNF	Poppet	Left hand – no grip	5.37	1.50	1.13	1.88
1/2	9250-16L-YE	7/8-14 UNF	Poppet	Left hand – yellow grip	5.37	1.50	1.13	1.89
1/2	9250-16R	7/8-14 UNF	Poppet	Right hand – no grip	5.37	1.50	1.13	1.88
1/2	9250-16R-RE	7/8-14 UNF	Poppet	Right hand – red grip	5.37	1.50	1.13	1.89
1/2	9250-16-320*	7/8-14 UNF	Poppet	Left hand – yellow grip	5.37	1.50	1.13	2.06
1/2	9250-334**	9/16-18 UNF	Poppet	Left hand – yellow grip	5.37	1.50	1.13	2.15

\* -320 indicates lower sleeve spring force for easier connection when coupler is not mounted in a clamp.

\*\* -334 couplers connect with 1/4" ISO 7241-B series nipples.

8010 Series Nipples

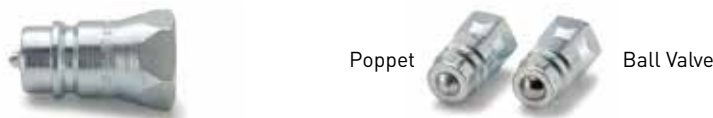

See page A-2 for additional ISO 5675 tip options.

Body Size	Coupler Part Number	Port End	Valve Type	Length	Largest Diameter	Wrench Flats	Weight (lbs.)
1/4	H2-63-T6*	9/16-18 ORB	Poppet	1.54	1.01	0.88	0.10
1/2	8010-4	1/2-14 NPTF	Ball	1.95	1.23	1.06	0.20
1/2	8010-4P	1/2-14 NPTF	Poppet	1.95	1.23	1.06	0.20
1/2	8010-15	3/4-16 ORB	Ball	1.95	1.23	1.06	0.20
1/2	8010-15P	3/4-16 ORB	Poppet	1.95	1.23	1.06	0.20
1/2	8010-16	7/8-14 ORB	Ball	1.95	1.23	1.06	0.25
1/2	8010-16P	7/8-14 ORB	Poppet	1.95	1.23	1.06	0.25

\* Connects with 9250-334 couplers



### 9200 Series Replacement Parts

Body Size	Part Number	Description	Weight (lbs.)
1/2	50001-211-0260	Interface O-Ring	.01
1/2	92-805-L4	Replacement Lever (Left hand)	.23
1/2	92-805-R4	Replacement Lever (Right hand)	.23
1/2	92-806-4	Replacement Yellow Grip (Left hand)	.01
1/2	92-807-4	Replacement Red Grip (Right hand)	.01
1/2	92-813-4	Replacement Black Grip (Right hand)	.01
1/2	92-814-L4	Replacement Cam Stop (Left hand)	.01
1/2	92-814-R4	Replacement Cam Stop (Right hand)	.01
1/2	92-906-4A	Wave Washer	.01

### 9200 Series Accessories

Body Size	Part Number	Clamp Type
1/2	9006-4	Breakaway - double
1/2	9507-4-1H	Automatic Dust Cover

NOTE: 9507-4-1H automatic dust cover cannot be used without the 9006-4 clamp.

### 9200 Series Dust Caps and Plugs

Body Size	Coupler Dust Cover	Color/Material	Nipple Dust Cap	Weight (lbs.)
1/2	9507-4-1	Black Rubber	5209-4M	.04

NOTE: 9507-4-1 rubber dust cover can be used with or without the 9006-4 clamp.





9500 Series Kits combines two color coded 9250 couplers with a 9006-4 clamp and dust protection. The dust covers automatically close when the male tip is removed and are color coordinated with the coupler lever handles to easily identify raise and lower lines. The 9502 Series Kits are preassembled and ready for use. 9250 couplers accept 8010 (ISO 5675) tips and are not included with the kit.

**Kit contents:**

- (1) 9250 Coupler (right hand orientation)
- (1) 9250 Coupler (left hand orientation)
- (1) 9006-4 Clamp Assembly
- (1) 9507-4-1H Automatic Dust Cover Assembly



Quick Couplings

**Open Position**



9250 Series

By turning the rugged, color-coded lever to "Open" you lock open the valves in both the female body and the male tip, so they are unaffected by rapid variations in fluid flow.

Turning the lever to Open without a male tip in place will not result in oil flow. The 9250 Series design prevents this from happening.

Valves will close automatically in the case of a breakaway.

**Closed Position**



9250 Series

In the Closed position the 9250 shuts off oil flow at the remote outlet. This allows for easy, sprayless, zero-pressure connecting or disconnecting and for additional safety when working on an implement.

Levers are color-coded to identify Raise and Lower lines.

Body Size	Part Number	Port End	Description	Rated Pressure (psi)	Sleeve Diameter	Flats	Clamp	Dust Cover
1/2	9500-4	1/2-14 NPTF	Kit	3000	1.50	1.13	9006-4	9507-4-1H
1/2	9500-16	7/8-14 ORB	Kit	3000	1.50	1.13	9006-4	9507-4-1H
1/2	9502-4	1/2-14 NPTF	Kit (assembled)	3000	1.50	1.13	9006-4	9507-4-1H





The 5000 Series is an economical coupling that can be connected under pressure where tools can be used to make the connection. The coupler and nipple are connected and then the valves are opened from tightening the threaded union on the back of the coupler body. Unscrewing the body threads will permit the valves to close and the coupler sleeve can be retracted to release the nipple.

### Features:

- Accepts ISO 5675 universal tips
- Manual, threaded actuation, connect under pressure coupling
- Protective zinc plating with clear trivalent chromate finish

### Applications include:

- Lubrication systems
- Hydraulic tools
- Attachments

### 5000 Series Specifications

Body Size	Rated Flow	Rated Pressure	Temperature	Body Material	Sleeve Type	Seal Material
1/2	12 gpm	2500 psi	-40° F to +250° F	Steel	Single Acting	Nitrile

### Performance:

5000 Series (1/2")  
Test Fluid: Oil - 200 SUS

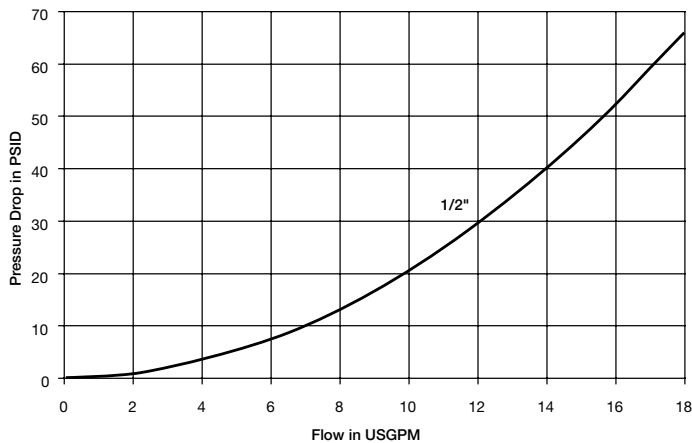

1/8"

1/4"

3/8"

1/2"

5/8"

3/4"

1"

1-1/4"

1-1/2"



**5000 Series Couplers**



Body Size	Coupler Part Number	Port End	Valve Type	Length	Largest Diameter	Wrench Flats	Weight (lbs.)	Complete Coupling Part Number
1/2	5050-4	1/2-14 NPTF	Ball	2.88	1.52	1.25	2.58	5000-4

**8010 Series Nipples**



Ball Valve

See page A-2 for additional ISO 5675 tip options.

Body Size	Coupler Part Number	Port End	Valve Type	Length	Largest Diameter	Wrench Flats	Weight (lbs.)	Complete Coupling Part Number
1/2	8010-4	1/2-14 NPTF	Ball	1.95	1.23	1.06	0.20	5000-4
1/2	8010-15	3/4-16 ORB	Ball	1.95	1.23	1.06	0.20	-
1/2	8010-16	7/8-14 ORB	Ball	1.95	1.23	1.06	0.25	-

**5000 Replacement Parts** 1/2

<b>O-Rings - Nitrile</b>	50001-211-0260
--------------------------	----------------

**5000 Series Dust Caps and Plugs**



Body Size	Dust Plugs (Coupler)	Color/Material	Dust Cap (Nipple)	Weight (lbs.)
3/8	5205-3M	Black Rubber	5209-3M	.03
1/2	5205-4M	Black Rubber	5209-4M	.04
1/2	5205-4M-BU	Blue Rubber	5209-4M-BU	.04
1/2	5205-4M-GR	Green Rubber	5209-4M-GR	.04
1/2	5205-4M-RE	Red Rubber	5209-4M-RE	.04
1/2	5205-4M-YE	Yellow Rubber	5205-4M-YE	.04
1/2	5005-4	Steel w/Chain	5009-4	.21

# Catalog 3900 - Agricultural Coupling Clamps

<b>5001-4 Single breakaway clamp</b>	
	Designed for use with all Pioneer couplers having a 1-1/2" diameter sleeve (1/2" body size). Yokes and braces are heavy duty metal stampings.
<b>5006-4 Double breakaway clamp</b>	
	Designed for use with all Pioneer couplers having a 1-1/2" diameter sleeve (1/2" body size). Yokes and braces are heavy duty metal stampings.
<b>9006-4 Double breakaway clamp</b>	
	Designed for use with 9250 lever couplers. Steel material bar with heavy duty diecast yoke.



- 1/8"
- 1/4"
- 3/8"
- 1/2"
- 5/8"
- 3/4"
- 1"
- 1-1/4"
- 1-1/2"

# Catalog 3900 - Agricultural Quick Coupling Adapters

Pioneer adapters shown here provide the most reliable and exacting interchange in the industry.

## How To Connect Using An Adapter

- Step 1** Relieve trapped pressure in the implement line.
- Step 2** Connect male tip on the implement line into the adapter.
- Step 3** Connect the Adapter into the female body.

**To Disconnect:** Reverse the above procedure: first disengage adapter from female body, then male tip from adapter.



	Part Number	Adapts This Style Of Male Tip	To This Female Body
	4060-4	Pioneer Style	John Deere Old Style
	4065-4	John Deere Old Style	Pioneer Style
	4065-4L	John Deere Old Style	John Deere 50 Series Ford/ISO Pioneer 9250
	4067-4	John Deere Old Style	International Harvester Old Style
	4068-4	John Deere Old Style	J I Case Old Style
	4070-4	Pioneer Style	International Harvester Old Style
	4075-4	International Harvester Old Style	Pioneer Style
	4075-4L	International Harvester Old Style	John Deere 50 Series Ford/ISO Pioneer 9250
	4076-4	International Harvester Old Style	John Deere Old Style
	4080-4	Pioneer Style	J I Case Old Style
	4085-4	J I Case Old Style	Pioneer Style

Quick Couplings

# Catalog 3900 - Agricultural Quick Coupling Adapters

## To select the proper Pioneer adapter:

Locate your tractor coupler along the left vertical column. Then locate your implement nipple along the top horizontal column. Now follow these two rows inward until they intersect at the correct adapter. For example: The proper adapter to connect a tractor with a Pioneer coupler to an implement with a J.I. Case nipple would be a 4085-4.

Male Tips / Female Bodies	John Deere	Pioneer ISO Tip	International Harvester	J.I. Case (old)	FE / FEM Series Bobcat, John Deere, Gehl, New Holland
	NO ADAPTER REQUIRED	4060-4	4076-4	N/A	N/A
	4065-4L	NO ADAPTER REQUIRED	4075-4L	N/A	N/A
	4067-4	4070-4	NO ADAPTER REQUIRED	N/A	N/A
	4068-4	4080-4	N/A	NO ADAPTER REQUIRED	N/A
	4065-4L	NO ADAPTER REQUIRED	4075-4L	N/A	N/A
	4065-4	NO ADAPTER REQUIRED	4075-4	4085-4	EAS-500
	N/A	SAE-500	N/A	N/A	N/A
	N/A	4069-4	N/A	N/A	N/A

\* Pioneer Couplers include: 4000, 4200, 6600, 8200, 8450, 9200, and 5000 Series

# Catalog 3900 - Original Equipment Products

Pioneer offers the most complete line of products in the industry.

## Interchangeable Products For:

Quick Couplings



**SM-502-8FP, Male Tip - replaces 4610-4.** Connects with Allis-Chalmers 255018 and similar couplers. Has positive sealing poppet valve. Case hardened for wear resistance, zinc plated for corrosion protection.



**5080-4, Male Tip.** Connects with J I Case A28542 and similar couplers. Has positive sealing poppet valve and shielded valve retainer to prevent flow checking. Case hardened and zinc plated for long service.



**8010-4P, Male Tip.** Connects with Ford and similar couplers. Has positive sealing poppet valve.



**\* 5060-4, Male Tip.** Fits John Deere AR47331 sleeve-type female bodies. Has durable chrome alloy precision ball valve. Induction hardened at the locking groove to minimize brinelling, and zinc plated for corrosion protection.



**\* 5060-15, Male Tip.** Also fits John Deere AR47331 (See 5060-4), but has 3/4-16 O-ring boss thread.



**4056-4.** Connects with John Deere AR30210 and Pioneer 5060-4 male tips. Interchange for John Deere AR47331. Has a single acting sleeve and will connect only after trapped pressure has been released.



**4056-15.** Connects with John Deere AR30210 and Pioneer 5060-15 male tips. Inter-change for John Deere AR47331 coupler. Has single-acting sleeve.

Allis-Chalmers				
Product Description	Pioneer Part Number	O.E.M. Part Number	Port End	Rated (psi) Pressure
Allis-Chalmers Old Style Male Tip	SM-502-8FP	247336	1/2 NPTF	3000

J I Case				
Product Description	Pioneer Part Number	O.E.M. Part Number	Port End	Rated (psi) Pressure
J I Case Old Style Male Tip	5080-4	A160884	1/2 NPTF	3000

Ford				
Product Description	Pioneer Part Number	O.E.M. Part Number	Port End	Rated (psi) Pressure
Ford	8010-4P	D-3NN-B964A	1/2 NPTF	3000

John Deere				
Product Description	Pioneer Part Number	O.E.M. Part Number	Port End	Rated (psi) Pressure
John Deere Male Tip	5060-4	RE-11447	1/2 NPTF	3000
John Deere Male Tip	5060-15	AR30210 (old) AR93819 (new)	3/4 O-Ring Boss	3000
John Deere Female Tip	4056-4	N.A.	1/2 NPTF	3000
John Deere Female Tip	4056-15	AR47331 (old) RE15361 (new)	3/4 O-Ring Boss	3000



**5070-4, Male Tip.** Fits I-H 544788R1 and Pioneer 4057-4 female bodies. Ball style valving. Heat treated and zinc plated for resistance to wear and corrosion.



**5070-16, Male Tip.** Also fits I-H 544788R1 and Pioneer 4057-4 female bodies. Ball style valving, heat treated and zinc plated for resistance to wear and corrosion. 7/8 -14 O-ring boss thread.



**5077-4, Male Tip.** Fits I-H 395150-R1 (gold style) coupler. Positive sealing poppet valve. Heat treated and zinc plated for resistance to wear and corrosion.



**5077-16, Male Tip.** Also fits I-H 395150-R1 (See 5077-4), but has 7/8 -14 O-ring boss thread. Notched hex for easy identification.



**4057-4, coupler.** Connects with I-H 544787R91 and Pioneer 5070-4 male tips. Interchange for I-H 544788R1. Has single-acting sleeve; trapped pressure must be released to make connection. Precision ball-check valving. Zinc plated.



**8010 Series Universal Male Tip.** The standard male tip of the agricultural industry, Rugged, reliable ball valve and induction-hardened locking ball groove. Shielded valve plus valve stop eliminates flow checking when used with connect-under-pressure type couplers. Tapered hex design for easy identification.

International Harvester (currently Case New Holland)				
Product Description	Pioneer Part Number	O.E.M. Part Number	Port End	Rated (psi) Pressure
I H Male Tip	5070-4	B91308	1/2 NPTF	3000
I H Male Tip	5070-16	544787R91	7/8 O-Ring Boss	3000
I H Male Tip	5077-4	395151R1	1/2 NPTF	3000
I H Male Tip	5077-16	395149R1	7/8 O-Ring Boss	3000
I H Female Body	4057-4	544788R1	1/2 NPTF	3000

Other Tractor Manufacturer Specifications				
Product Description	Pioneer Part Number	O.E.M. Part Number	Port End	Rated (psi) Pressure
Massey-Ferguson Male Tip	8010-4	242678M91	1/2 NPTF	3000
Massey-Ferguson Male Tip	8010-15	1026700M91	3/4-16 O-Ring Boss	3000



## State-of-the-Art Coupler Features Rigid Mounting and Connect/Disconnect Under Pressure



The Pioneer 0312-001 rigid mount coupler features a patented design that permits connection while both the coupler and male tip are under pressure.

These couplers can be mounted directly to a valve or rigid tubing, eliminating the need for hose assemblies and break-away clamps.

- Easy push/pull connection and disconnection under system pressure.
- Enclosed outer housing prevents dust and dirt build up.
- This coupler accepts all Pioneer 8010 Series or ISO 5675 male tips.
- Environmentally friendly Chromium 6 Free plating for excellent corrosion resistance

### Ordering Information

The 0312-001 is available in two packaging formats. Available in packages of five, or individually in the Valu-Pak clam shell for retail displays.

This coupler is the same product as **Kubota 3A111-82011**.

Specifications			
Body Size	Part Number	Thread	Pressure Rating (psi)
1/2	0312-001	7/8-14UNF-2B	3000 PSI
1/2	VP0312-001-CS	7/8-14UNF-2B	3000 PSI



## ISO 5675 Universal Male Tip for John Deere Equipment



The Pioneer tip has been the standard of the agriculture industry for over 60 years

The DR10008 male tip is manufactured to meet the original John Deere dimensional specifications, and has a slightly smaller hex size than a standard Pioneer tip.

- Meets all ISO 5675 dimensional specifications.
- Induction hardened ball locking groove to prevent brinelling and increase life.
- Shielded valve and valve stop eliminates flow checking.
- Leak-free poppet valve design
- Environmentally friendly Chromium 6 Free plating

### Ordering Information

The DR10008 is available in two packaging formats. Available in bulk packages of 25, or individually in the Valu-Pak clam shell.

This male tip is the same product as **John Deere AR94522**.

### Specifications

Body Size	Part Number	Thread	Pressure Rating (psi)
1/2"	DR10008	3/4-16 Female ORB	3000 PSI
1/2"	VPDR10008-CS	3/4-16 Female ORB	3000 PSI



1/8"

1/4"

3/8"

1/2"

5/8"

3/4"

1"

1-1/4"

1-1/2"



## Eliminate the need for adapters for your 4000 Series John Deere tractors

The Pioneer DR10010 cartridge conversion kit is designed to convert John Deere 4000 Series tractors for use with ISO 5675 Pioneer style tips.

Upgrading your tractor with this conversion kit will eliminate the need for adapters. You will no longer need to adapt implements using the ISO male tips to the old style John Deere coupling interface.

- Easy push/pull operation
- Reduced pressure drop for longer system life
- Simple and fast installation
- Chromium 6 Free plating on all steel components for excellent corrosion resistance.

### Ordering Information

This kit contains the components to convert two original John Deere couplings. (All of the components pictured above are included in the kit.)

This kit is the same product as **John Deere RE206778**.

### Specifications

Body Size	Part Number	Thread	Pressure Rating (psi)
1/2	DR10010	Kit	3000 PSI



Pioneer's Merchandising Boxes provide an effective point of purchase display for our products. Pioneer's most common products are shipped and displayed in the same convenient packaging. Simply fold the top of the box and you have an instant display card - complete with product description and part number.



**Heavy Duty Water Hose Couplings**

Part No.	Description	Qty
1163MB	Complete Coupling	10

**Male Tips**

8010-4MB	1/2" Male Tip 1/2" NPTF	10
8010-4PMB	1/2" Male Tip (Poppet Valve) 1/2" NPTF	10
5060-4MB	1/2" John Deere Male Tip 1/2" NPTF	10
5060-15MB	1/2" John Deere Male Tip 3/4" ORB	10
5070-4MB	1/2" Inter. Harvester Male Tip 1/2" NPTF	10
5070-16MB	1/2" Inter. Harvester Male Tip 7/8" ORB	10
5077-4MB	1/2" Old Style Inter. Harvester Male Tip 1/2" NPTF	10
5077-16MB	1/2" Old Style Inter. Harvester Male Tip 7/8" ORB	10
5080-4MB	1/2" Old Style J.I. Case Male Tip 1/2" NPTF	10

**Quick Coupling Adapters**

4060-4MB	Pioneer Male Tip to John Deere Female Body	5
4065-4MB	John Deere Male Tip to Pioneer Female Body	5
4067-4MB	John Deere Male Tip to Inter. Harvester Female Body	5
4068-4MB	John Deere Male Tip to Old Style J. I. Case Female Body	5
4070-4MB	Pioneer Male Tip to Inter. Harvester Female Body	5
4075-4MB	Inter. Harvester Male Tip to Pioneer Female Body	5
4080-4MB	Pioneer Male Tip to Old Style J. I. Case Female Body	5
4085-4MB	Old Style J. I. Case Male Tip to Pioneer Female Body	5

**Quick Coupling Sets/ Quick Couplers**

4000-4MB	1/2" Complete Coupling 1/2" NPTF	5
4000-4PMB	1/2" Complete Coupling (Poppet Valve) 1/2" NPTF	5
4050-4MB	1/2" Female Body 1/2" NPTF	5
4050-4PMB	1/2" Female Body (Poppet Valve) 1/2" NPTF	5
4056-4MB	1/2" John Deere Female Body 1/2" NPTF	5
4056-15MB	1/2" John Deere Female Body 3/4" ORB	5
4057-4MB	1/2" International Harvester Female Body 1/2" NPTF	5
4200-4MB	1/2" Complete Coupling 1/2" NPTF	5
4200-4PMB	1/2" Complete Coupling (Poppet Valve) 1/2" NPTF	5
4250-4MB	1/2" Female Body 1/2" NPTF	5
4250-4PMB	1/2" Female Body (Poppet Valve) 1/2" NPTF	5
8200-4MB	1/2" Complete Coupling (Poppet Valve) 1/2" NPTF	5
8250-4MB	1/2" Female Body 1/2" NPTF	5
9250-4MB	1/2" One Right and one Left Coupler	2



**8500 Kit**

Contains 8200 Series couplings and accessories.

For connections having pressure on either tractor side or implement lines, or both.

**8500 kit contains:**

- (2) 8250-4 female bodies
- (2) 5205-4M dust plugs
- (2) 8010-4 male tips
- (2) 5209-4M dust caps
- (1) 5006-4 clamp



**8700 Series ISO Conversion Kit**

Upgrade International Harvester tractors to accept ISO male tips models 1971 to 1983.

- Converts lever style tractors to accept ISO interchange male tips
- Easy push/pull connect and disconnection
- Reduced pressure drop – longer system life
- Simple, fast installation
- Dust cap keeps dust and dirt out

OEM Kit



8700 Kit



**9500 Kit**

Contains 9200 Series couplers and accessories.

For connect and disconnect at zero pressure, even with pressurized lines.

**9500 kit contains:**

- (2) 9250 female bodies
- (1) 9507-4-1H automatic dust cover
- (1) 9006-4 double breakaway clamp



Dimensions:  
22 1/2" x 26 3/4" x 14"



**Color Coded  
Dust Caps and Plugs  
K404-CDP**

Color coded dust caps and plugs are perfect for preventing mismatched connections. They also prevent contamination and protect couplers and nipples from damage. Simply match the color to the original equipment manufacturer.

K404-CDP kit contains:			
Part No.	Color	Description	Qty
5205-4M	Black	Dust Plug	16
5209-4M	Black	Dust Cap	16
5205-4M-BU	Blue	Dust Plug	8
5209-4M-BU	Blue	Dust Cap	8
5205-4M-GR	Green	Dust Plug	16
5209-4M-GR	Green	Dust Cap	16
5205-4M-RE	Red	Dust Plug	8
5209-4M-RE	Red	Dust Cap	8
5205-4M-YE	Yellow	Dust Plug	8
5209-4M-YE	Yellow	Dust Cap	8
K404-EX	Black	Overhead Extension	1

NOTE: The Orange and Purple dust caps that were offered in the original display have been discontinued.

NOTE: If you have an existing K404 display rack, you can order part number K404-UPGRADE. This will include the above items (individual quantities may vary) and the new decal. You will not receive the Gravity Display Wire Rack.

### Maximize Your Profits and Increase Sales

For nearly 20 years the K404 gravity feed display has been a favorite marketing tool for the Pioneer retail segment, allowing you to maximize profits from a minimal amount of space.

As the hydraulic market continues to evolve, so do the coupling requirements of the agricultural customer. This attractive full color merchandising display will put today's most popular coupling products in front of your customer.

The new colorful decal will assist you in making the correct product choice for your customer's application.

### Gravity Feed Counter Display Features:

- Thirteen merchandise slots for increased visibility of Pioneer's most active and profitable products
- Full color laminated decal with specifications, photos and the features and benefits of each product.
- Expandable to include the K404-CDP color coded dust caps and plugs for maintaining proper connections.
- Expanded product offering that includes the popular FEM Series skid loader couplings.



**K404 Gravity Feed Display  
K404-STK**

The Pioneer K404 Gravity Feed Display has been upgraded to include today's most popular products. This time proven sales tool will help you maximize your profits from counter sales. This is a great opportunity to put a product in your customer's hand. Quality and durability make these products 'The Farmers Choice'.

K404-STK kit contains:		
Part No.	Description	Qty
8010-4	ISO Tip, 1/2" NPT, Ball Valve	10
8010-4P	ISO Tip, 1/2" NPT, Poppet Valve	10
8010-4P-DC	ISO Tip, 1/2" NPT, Pressure Release	10
DR10008	John Deere Style ISO Tip	10
5060-4	John Deere Old Style Tip, 1/2" NPT	10
5060-15	John Deere Old Style Tip, 3/4" ORB	10
4050-4	ISO Coupler, Single Acting Sleeve	5
4250-4	ISO Coupler, Double Acting Sleeve	5
8250-4	ISO Coupler, Connect-Under-Pressure	5
FEM-501-8FP-NL	Skid Steer/Construction Coupler, 1/2" NPT	5
FEM-502-8FP	Skid Steer/Construction Nipple, 1/2" NPT	5
4060-4	Pioneer to John Deere Old Style Adapter	5
4065-4	John Deere Old Style to Pioneer Adapter	5
K404	Gravity Display Wire Rack	1
K404-DECAL	Decal	1

**Packaging That's Better Than Ever**

Look at these advantages:

- Valu-Pak is compact – takes less room. Hangs easily from peg board.
- Clear blister-pac reveals enclosed product and protects it from dust, dirt and thread damage.
- Valu-Pak is environmentally friendly. Package is reusable and recyclable.
- Products displayed in Valu-Pak provide a well organized stock, better inventory control and less opportunity for theft.
- Package includes product part number, description, and bar code.



**Valu-Pak Male Tips**

Part No.	Description	Qty
VP4010-2P-CS	1/4" Male Tip (Poppet Valve) 1/4" NPTF	1
VP4010-3P-CS	3/8" Male Tip (Poppet Valve) 3/8" NPTF	1
VP8010-4-CS	1/2" Male Tip 1/2" NPTF	1
VP8010-4P-CS	1/2" Male Tip (Poppet Valve) 1/2" NPTF	1
VP8010-4P-DC-CS	1/2" Decompression Nipple 1/2" NPTF	1
VP8010-5-CS	1/2" Male Tip 3/4" NPTF	1
VP8010-15-CS	1/2" Male Tip 3/4" ORB	1
VP8010-15P-CS	1/2" Male Tip (Poppet Valve) 3/4" ORB	1
VP8010-16-CS	1/2" Male Tip 7/8" ORB	1
VP8010-16P-CS	1/2" Male Tip (Poppet Valve) 7/8" ORB	1
VP5060-4-CS	1/2" John Deere Male Tip 1/2" NPTF	1
VP5060-15-CS	1/2" John Deere Male Tip 3/4" ORB	1
VP5070-4-CS	1/2" Inter. Harvester Male Tip 1/2" NPTF	1
VP5070-16-CS	1/2" Inter. Harvester Male Tip 7/8" ORB	1
VP5077-4-CS	1/2" Old Style Inter. Harvester Male Tip 1/2" NPTF	1
VP5077-16-CS	1/2" Old Style Inter. Harvester Male Tip 7/8" ORB	1
VP5080-4-CS	1/2" Old Style J. I. Case Male Tip 1/2" NPTF	1
VP8010-15P-DC-CS	1/2" Decompression Nipple 3/4" ORB	1

**Valu-Pak Heavy Duty Water Hose Couplings**

VP1163-CS	Complete Coupling	1
VP1163-60-CS	Female Half	1
VP1163-61-CS	Male Half	1
VP6-4730001-CS	Washer (package of six)	1

**Valu-Pak High Pressure Water Couplings**

VPST-N2M-CS	1/4" Steel Nipple 1/4" Male Thread	1
VPST-N3M-CS	3/8" Steel Nipple 3/8" Male Thread	1
VPST-N2-CS	1/4" Steel Nipple 1/4" Female Thread	1
VPST-N3-CS	3/8" Steel Nipple 3/8" Female Thread	1
VPBST-2MSL-CS	1/4" Brass Coupler 1/4" Male Thread	1
VPBST-3MSL-CS	3/8" Brass Coupler 3/8" Male Thread	1
VPBST-2SL-CS	1/4" Brass Coupler 1/4" Female Thread	1
VPBST-3SL-CS	3/8" Brass Coupler 3/8" Female Thread	1



Valu-Pak Quick Coupling Adapters		
Part No.	Description	Qty
VP4060-4-CS	Pioneer Male Tip to John Deere Female Body	1
VP4065-4-CS	John Deere Male Tip to Pioneer Female Body	1
VP4065-4L-CS	John Deere Male Tip to New John Deere Female Body	1
VP4067-4-CS	John Deere Male Tip to Inter. Harvester Female Body	1
VP4070-4-CS	Pioneer Male Tip to Inter. Harvester Female Body	1
VP4075-4-CS	Inter. Harvester Male Tip to Pioneer Female Body	1
VP4075-4L-CS	Inter. Harvester Male Tip to New John Deere Female Body	1
VP4076-4-CS	Inter. Harvester Male Tip to John Deere Female Body	1
VP4080-4-CS	Pioneer Male Tip to Old Style J. I. Case Female Body	1
VP5060-15-CS	1/2" John Deere Male Tip 3/4" ORB	1
VP5070-4-CS	1/2" Inter. Harvester Male Tip 1/2" NPTF	1
VP5070-16-CS	1/2" Inter. Harvester Male Tip 7/8" ORB	1
VP5077-4-CS	1/2" Old Style Inter. Harvester Male Tip 1/2" NPTF	1
VP5077-16-CS	1/2" Old Style Inter. Harvester Male Tip 7/8" ORB	1
VP5080-4-CS	1/2" Old Style J. I. Case Male Tip 1/2" NPTF	1

Valu-Pak Dust Caps and Plugs		
VP5205-2M-CS	Black Dust Plug 1/4" (package of 2)	1
VP5205-3M-CS	Black Dust Plug 3/8" (package of 2)	1
VP5205-4M-CS	Black Dust Plug 1/2" (package of 2)	1
VP5205-4M-GR-CS	Green Dust Plug 1/2" (package of 2)	1
VP5205-4M-RE-CS	Red Dust Plug 1/2" (package of 2)	1
VP5205-4M-BU-CS	Blue Dust Plug 1/2" (package of 2)	1
VP5205-4M-YE-CS	Yellow Dust Plug 1/2" (package of 2)	1
VP5205-5M-CS	Black Dust Plug 3/4" (package of 2)	1
VP5209-2M-CS	Black Dust Cap 1/4" (package of 2)	1
VP5209-3M-CS	Black Dust Cap 3/8" (package of 2)	1
VP5209-4M-CS	Black Dust Cap 1/2" (package of 2)	1
VP5209-4M-GR-CS	Green Dust Cap 1/2" (package of 2)	1
VP5209-4M-RE -CS	Red Dust Cap 1/2" (package of 2)	1
VP5209-4M-BU -CS	Blue Dust Cap 1/2" (package of 2)	1
VP5209-4M-YE -CS	Yellow Dust Cap 1/2" (package of 2)	1
VP5209-5M-CS	Black Dust Cap 3/4" (package of 2)	1





**Valu-Pak Hydraulic Quick Couplings, Adapters and O-rings**

Part No.	Description	Qty
VP4050-2P-CS	1/4" Female Body (Poppet Valve) 1/4" NPTF	1
VP4000-2P-CS	1/4" Complete Coupling (Poppet Valve) 1/4" NPTF	1
VP4000-3P-CS	3/8" Complete Coupling (Poppet Valve) 3/8" NPTF	1
VP4000-4-CS	1/2" Complete Coupling 1/2" NPTF	1
VP4000-4P-CS	1/2" Complete Coupling (Poppet Valve) 1/2" NPTF	1
VP4000-16-CS	1/2" Complete Coupling 7/8" ORB	1
VP4050-4-CS	1/2" Female Body 1/2" NPTF	1
VP4050-4P-CS	1/2" Female Body (Poppet Valve) 1/2" NPTF	1
VP4056-4-CS	1/2" John Deere Female Body 1/2" NPTF	1
VP4056-15-CS	1/2" John Deere Female Body 3/4" ORB	1
VP4057-4-CS	1/2" International Harvester Female Body 1/2" NPTF	1
VP4200-3P-CS	3/8" Complete Coupling (Poppet Valve) 3/8" NPTF	1
VP4200-4-CS	1/2" Complete Coupling 1/2" NPTF	1
VP4200-4P-CS	1/2" Complete Coupling (Poppet Valve) 1/2" NPTF	1
VP4250-4-CS	1/2" Female Body 1/2" NPTF	1
VP4250-4P-CS	1/2" Female Body (Poppet Valve) 1/2" NPTF	1
VP8200-4-CS	1/2" Complete Coupling (Poppet Valve) 1/2" NPTF	1
VP8250-4-CS	1/2" Female Body 1/2" NPTF	1
VPEAS-500-CS	Non-Spill Adapter	1
VPFEM-501-10BMF-NL-CS	Non-Spill Coupler	1
VPFEM-501-10BMS-NL-CS	Non-Spill Coupler	1
VPFEM-501-10FO-NL-CS	Non-Spill Coupler	1
VPFEM-501-8FP-NL-CS	Non-Spill Coupler	1
VPFEM-501-12FO-NL-CS	Non-Spill Coupler	1
VPFEM-502-10BMF-CS	Non-Spill Nipple	1
VPFEM-502-10BMS-CS	Non-Spill Nipple	1
VPFEM-502-10FO-CS	Non-Spill Nipple	1
VPFEM-502-8FP-CS	Non-Spill Nipple	1
VPFEM-502-12FO-CS	Non-Spill Nipple	1
VPFEC-502-12FO-CS	Connect-Under-Pressure Nipple	1
VPSAE-500-CS	Non-Spill Adapter	1
VP2-211N0552-90-CS	O-Rings 1/2" Body Size (5 pack)	1

**Blister Pak Pneumatic Quick Couplings**

Part No.	Description	Qty
DP-PKR-2004-01	(1) B23 Manual Connect 20 Series Coupler	1
DP-PKR-2004-02	(1) H2C Manual Connect 20 Series Nipple	1
DP-PKR-2004-03	(1) B22 Manual Connect 20 Series Coupler	1
DP-PKR-2004-04	(1) H3C Manual Connect 20 Series Nipple	1
DP-PKR-2004-05	(1) B23 & (1) H2C Manual Connect 20 Series Complete Coupling	1
DP-PKR-2006-08	(1) 25 & (1) H2E Manual Connect 20 Series Complete Coupling	1
SPUC304F-4	(1) UC304F-4 Push-to-Connect UC, "Universal" coupler	12
SPUC304M-4	(1) UC304M-4 Push-to-Connect UC, "Universal" coupler	12
SPUCN304F-4	(1) UC304F-4 (1) H2C Push-to-Connect UC, "Universal" nipple	12



The 3000 Series coupling are designed for high pressure applications. The coupler sleeve and nipple body must be manually threaded together to make the connection.

**Features:**

- Manual threaded connection and actuation
- Hard, chrome alloy ball valves
- Polyurethane interface seal resists high pressure extrusion
- Threaded retainer provides a positive valve stop
- Protective zinc plating with clear trivalent chromate finish

**Applications include:**

- Hydraulic rams
- Portable hydraulic tools
- Crimping equipment

3000 Series Specifications						
Body Size	Rated Flow (gpm)	Rated Pressure (psi)	Temperature	Body Material	Sleeve Type	Seal Material
1/4	3	10,000	-22° F to +230° F	Steel	Thread to connect	Polyurethane
3/8	6			Steel	Thread to connect	Polyurethane

**Performance:**

3000 Series (1/4", 3/8")  
Test Fluid: Oil - 200 SUS

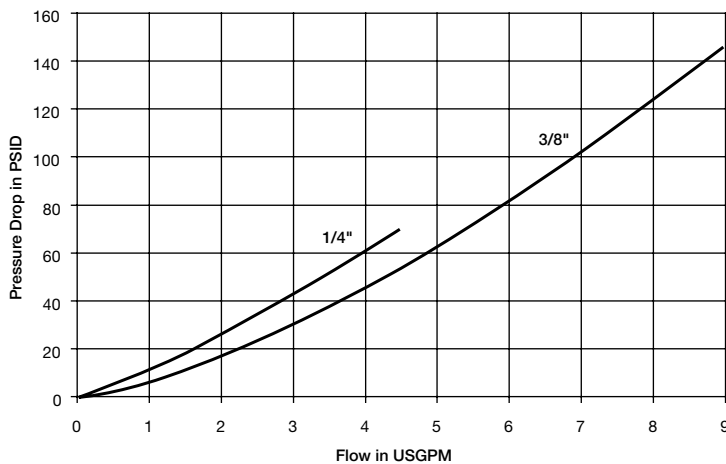



3000 Series Couplers



Body Size	Coupler Part Number	Port End	Valve Type	Length	Largest Diameter	Wrench Flats	Weight (lbs.)
1/4	3050-2	1/4-18 NPTF (Male)	Ball	2.38	1.13	0.81	0.25
3/8	3050-3	3/8-18 NPTF (Male)	Ball	2.38	1.38	1.00	0.49
3/8	3050-3-231	3/8-18 NPTF (Female)	Ball	2.38	1.38	1.00	0.49

3000 Series Nipples



Body Size	Coupler Part Number	Port End	Valve Type	Length	Largest Diameter	Wrench Flats	Weight (lbs.)
1/4	3010-2	1/4-18 NPTF (Female)	Ball	1.29	1.13	0.88	0.14
3/8	3010-3	3/8-18 NPTF (Female)	Ball	1.58	1.25	0.94	0.23
3/8	3010-3-230	3/8-18 NPTF (Male)	Ball	2.31	1.25	1.00	0.30

3000 Series Replacement O-Rings

Body Size	Material	Part Number	Durometer
1/4	Polyurethane	50001-114-0296	90
3/8	Polyurethane	50001-210-0296	90

3000 Series Dust Caps and Plugs



Body Size	Dust Cap (Nipple)	Color/Material	Dust Plug (Coupler)	Weight (lbs.)
1/4	3009-2	Steel	3005-2	.02
3/8	3009-3	Steel	3005-3	.04





FF Series couplings eliminate spillage and air inclusion when connecting and disconnecting. The sleeve locking mechanism prevents accidental disconnection. 3/8" body size complies with Hydraulic Tool Manufacturers Association standards. FC nipples provide a connect-under-pressure option for trapped pressures up to 3000 psi on the nipple side.

### Features

- Flush, non-spill valving
- Hardened steel sleeves and nipple bodies
- Locking sleeve
- Blow-out resistant seal
- Connect-under-pressure nipple option
- Protective zinc plating with clear trivalent chromate finish

### Applications include:

- Hydraulic tools

### Performance

FF Series (1/4", 3/8", 1/2")  
Test Fluid: Oil - 200 SUS

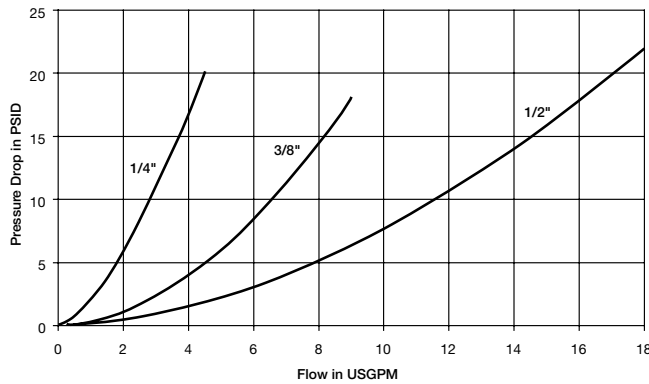

FF Series (3/4" & 1")  
Test Fluid: Oil - 200 SUS

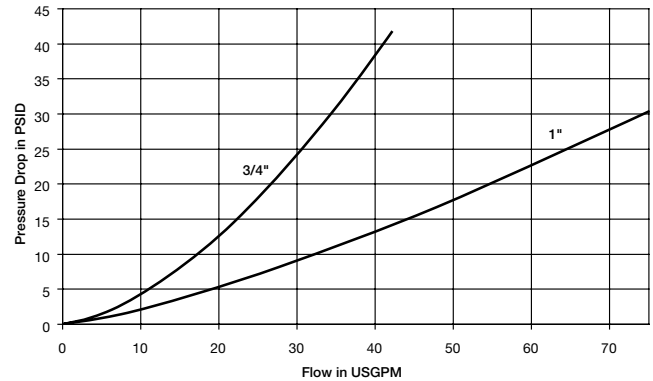

### FF Series Specifications

Body Size	Rated Pressure (psi)	Rated Flow (gpm)	Temperature Range	Spillage (ml) max. per disconnect	Air Inclusion (ml) max. per connect	Body Material	Sleeve Type	Seal Material
1/4	5000	3	-40° to +250°F	.015	.020	Steel	Push to Connect	Nitrile
3/8	3000	6		.015	.020			
1/2	3000	12		.020	.070			
3/4	3000	28		.150	.100			
1	3000	50		.200	.150			





**FF Series Couplers**



Body Size	Coupler Part Number	Port End	Length	Largest Diameter	Wrench Flats	Weight (lbs.)
1/4	FF-251-4FP	1/4-18 NPSF	1.79	1.06	1.00	0.23
1/4	FF-251-4MP	1/4-18 NPTF	1.84	1.06	1.00	0.24
1/4	FF-251-6FO	9/16-18 UNF	1.91	1.06	1.00	0.23
3/8	FF-371-6FP	3/8-18 NPSF	2.39	1.20	1.06	0.44
3/8	FF-371-8FP	1/2-14 NPSF	2.80	1.20	1.06	0.5
3/8	FF-371-6FB	G3/8 BSPP	2.45	1.20	1.06	0.45
3/8	FF-371-8FB	G1/2 BSPP	2.80	1.20	1.06	0.48
3/8	FF-371-8FO	3/4-16 UNF	2.82	1.20	1.06	0.52
1/2	FF-501-8FP	1/2-14 NPSF	2.67	1.54	1.25	0.88
1/2	FF-501-10FO	7/8-14 UNF	2.89	1.54	1.25	1.05
3/4	FF-751-12FP	3/4-14 NPSF	3.50	1.94	1.75	1.84
3/4	FF-751-12FO	1 1/16-12 UNF	3.75	1.94	1.75	1.93
1	FF-1001-16FP	1-11 1/2NPSF	4.14	2.25	1.87	2.64
1	FF-1001-16FO	1 5/16-12UNF	4.24	2.25	1.87	2.68

**FF Series Nipples**



Body Size	Coupler Part Number	Port End	Length	Largest Diameter	Wrench Flats	Weight (lbs.)
1/4	FF-252-4FP	1/4-18 NPSF	1.66	1.06	1.00	0.16
1/4	FF-252-4MP	1/4-18 NPTF	1.72	1.06	1.00	0.26
1/4	FF-252-6FO	9/16-18 UNF	1.66	1.06	1.00	0.16
3/8	FF-372-6FP	3/8-18 NPSF	2.31	1.08	0.94	0.26
3/8	FF-372-8FP	1/2-14 NPSF	2.64	1.19	1.06	0.32
3/8	FF-372-6FB	G3/8 BSPP	2.45	1.08	0.94	0.28
3/8	FF-372-8FB	G1/2 BSPP	2.70	1.19	1.06	0.32
3/8	FF-372-8FO	3/4-16 UNF	2.70	1.19	1.06	0.3
1/2	FF-502-8FP	1/2-14 NPSF	2.75	1.38	1.25	0.42
1/2	FF-502-10FO	7/8-14 UNF	2.75	1.38	1.25	0.44
3/4	FF-752-12FP	3/4-14 NPSF	3.38	1.73	1.50	1.00
3/4	FF-752-12FO	1 1/16-12 UNF	3.58	1.73	1.50	1.02
1	FF-1002-16FP	1-11 1/2 NPSF	3.85	2.17	1.87	1.60
1	FF-1002-16FO	1 5/16-12UNF	3.85	2.17	1.87	1.70

**Standard Port Configurations:** **FP** - Female Pipe Thread    **FO** - Female Straight Thread  
**MP** - Male Pipe Thread    **FB** - Female British Standard Pipe Parallel

# Catalog 3900 - Hydraulic Couplings Non-Spill

**FF/FC Series**  
**HTMA Standard (3/8" size)**  
Push to connect/sleeve lock



Quick Couplings

Optional Seals Suffix	
<b>E4</b>	Fluorocarbon
<b>E5</b>	Ethylene Propylene (EPR)
<b>E35</b>	Perfluoroelastomer (Contact Factory for Seal Options).

\* Optional seals include O-ring & Back-Up Ring, not Anti-Blow Out bonded seal.

FF Series Repair Kits				
1/4" Nipple	FF-252-KIT	FF-252-KIT-E4	FF-252-KIT-E5	-
1/4" Coupler	FF-251-KIT	FF-251-KIT-E4	FF-251-KIT-E5	FF/FS-251-TOOL
3/8" Nipple	FF-372-KIT	FF-372-KIT-E4	FF-372-KIT-E5	-
3/8" Coupler	N/A	N/A	N/A	N/A
3/4" Nipple	FF-752-KIT	FF-752-KIT-E4	FF-752-KIT-E5	-
3/4" Coupler	FF-751-KIT	FF-751-KIT-E4	FF-751-KIT-E5	FF/FS-751-TOOL
1" Nipple	FF-1002-KIT	FF-1002-KIT-E4	FF-1002-KIT-E5	-
1" Coupler	FF-1001-KIT	FF-1001-KIT-E4	FF-1001-KIT-E5	FF/FS-1001-TOOL

Dust Caps - FF Series			
	Body Size	Coupler Dust Cap-Rubber	Nipple Dust Cap-Rubber
		1/4	FR-25
	3/8	NR-50	NR-37
	1/2	FR-501	FR-502
	3/4	FR-751	FR-752
	1	FR-1001	FR-1002



**GOODYEAR**  
RUBBER PRODUCTS, INC.

**727-342-5088**

You can also email us at  
[GRP@goodyearrubberproducts.com](mailto:GRP@goodyearrubberproducts.com)



### Connect Under Pressure Operation

FC Series products operate slightly different from traditional non-spill couplings. With no pressure in the coupler and up to 3000 PSI of trapped pressure in the nipple, begin to couple the mating halves. Delay momentarily during connection to allow trapped pressure to equalize with the mating half before completing the connection.

FC Series nipples provide a connect-under-pressure option for trapped pressures up to 3000 psi on the nipple side.

### Features:

- Connect-under-pressure nipple
- Flush, non-spill valving
- Hardened locking surface
- Blow-out resistant seal
- Protective zinc plating with clear trivalent chromate finish

### Applications include:

- Hydraulic tools

### FC Series Specifications

Body Size	Rated Pressure (PSI)	Rated Connect-Under-Pressure Capability	Rated Flow (GPM)	Spillage (ML) max. per disconnect	Air Inclusion (ML) max. per connect
3/8	3000	3000	6	.015	.020
1/2	3000	3000	12	.020	.070
3/4	3000	3000	26	.150	.100

### Performance

FC Series (3/8", 1/2", 3/4")  
Test Fluid: Oil - 200 SUS

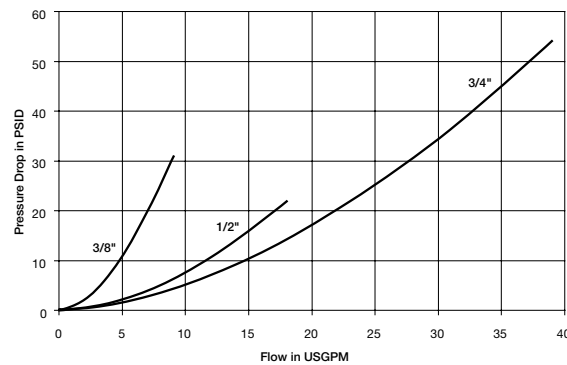

### FC Series Connect Under Pressure Nipples



Body Size	Part Number	Mating Half	Port End	Length	Largest Diameter	Wrench Flats	Weight (lbs.)
3/8	FC-372-6FP	FF-371	3/8-18 NPSF	3.30	1.16	1.062	0.45
3/8	FC-372-8FO	FF-371	3/4-16 UNF	3.30	1.16	1.062	0.42
3/8	FC-372-8FP	FF-371	1/2-14 NPSF	3.30	1.16	1.062	0.42
1/2	FC-502-8FP	FF-501	1/2-14 NPSF	3.46	1.22	1.125	0.53
1/2	FC-502-10FO	FF-501	7/8-14 UNF	3.46	1.22	1.125	0.52
3/4	FC-752-12FO	FF-751	1 1/16-12 UNF	4.81	1.65	1.500	1.32
3/4	FC-752-12FP	FF-751	3/4-14 NPSF	4.81	1.65	1.500	1.34

Standard Port Configurations: **FP** - Female Pipe Thread **FO** - Female Straight Thread



FEM Series couplings meet or exceed ISO 16028 design and performance requirements. The flush valves eliminate spillage and air inclusion when connecting and disconnecting. Coupler and nipple bodies have a modular design with increased flexibility for end port options. FEC nipples provide a connect-under-pressure option for trapped residual pressure.

### Features

- Flush, non-spill valving
- Global interchangeability with other ISO 16028 compliant couplings
- Hardened steel sleeves and nipple bodies
- Optional locking sleeve
- Blow-out resistant seal
- Connect-under-pressure nipple option
- Protective zinc plating with clear trivalent chromate finish

### Applications include:

- Skid loader attachments
- Hydraulic tools

### Materials of Construction

- Body:** Steel  
**Finish:** Chromium-6 Free plating  
**Valve:** Flush face valving  
**Seal:** Polyurethane or Nitrite; size dependant

### Performance

FEM Series (1/4", 3/8", 1/2")  
Test Fluid: Oil - 150 SUS

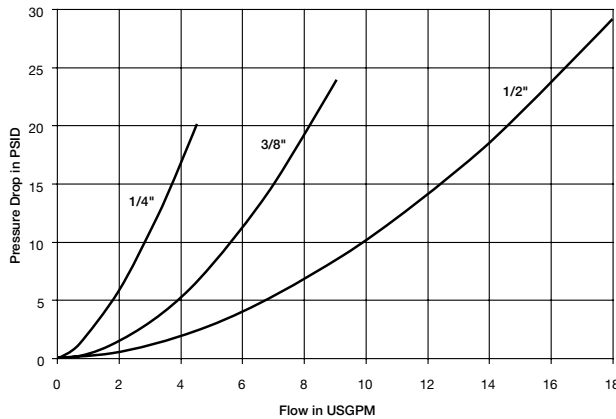

FEM Series (5/8", 3/4", 1")  
Test Fluid: Oil - 150 SUS

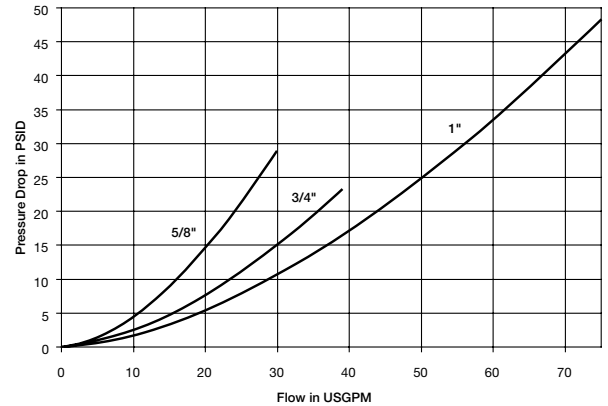

### FEM Series Specifications

Body Size	Rated Pressure (psi)	Rated Flow (gpm)	Temperature Range	Spillage (ml) max. per disconnect	Air Inclusion (ml) max. per connect	Body Material	Sleeve Type	Seal Material
1/4	4568	3	-40° to +250°F	.015	.020	Steel	Push to Connect	Nitrile
3/8	3625	6		.015	.020			
1/2	3625	12		.020	.070			
5/8	3625	20		.030	.070			
3/4	3625	28		.150	.100			
1	2900	50		.200	.150			





FEM Series Couplers



Body Size	Coupler Part Number	Port End	Length	Largest Diameter	Wrench Flats	Weight (lbs.)
1/4	FEM-251-4FP-NL	1/4-18 NPSF	1.96	1.16	27mm	0.52
1/4	FEM-251-6FO-NL	9/16-18 UNF	2.08	1.16	27mm	0.51
3/8	FEM-371-6FP-NL	3/8-18 NPSF	2.89	1.26	30mm	0.68
3/8	FEM-371-8FO-NL	3/4-16 UNF	2.89	1.26	30mm	0.68
1/2	FEM-501-8FP-NL	1/2-14 NPSF	2.96	1.54	1.25	0.93
1/2	FEM-501-8FO-NL	3/4-16 UNF	2.96	1.54	1.25	0.93
1/2	FEM-501-10FO-NL	7/8-14 UNF	2.96	1.54	1.25	0.93
1/2	FEM-501-12FO-NL	1 1/16-12 UNF	3.21	1.54	1.25	0.93
5/8	FEM-621-12FO-NL	1 1/16-12 UNF	3.70	1.69	40mm	1.34
3/4	FEM-751-12FP-NL	3/4-14 NPSF	3.95	1.97	46mm	1.98
3/4	FEM-751-12FO-NL	1 1/16-12 UNF	3.95	1.97	46mm	2.00
1	FEM-1001-16FP-NL	1-11 1/2-NPSF	4.21	2.36	55mm	3.08
1	FEM-1001-16FO-NL	1 5/16-12 UNF	4.21	2.36	55mm	3.03

FEM Series Couplers (Bulkhead)



Body Size	Coupler Part Number	Port End	Length	Largest Diameter	Wrench Flats	Weight (lbs.)
1/2	FEM-501-10BMF-NL	7/8-14 UNF	4.04	1.54	1.25	1.13
1/2	FEM-501-10BMS-NL	1-14 UNS	4.04	1.548	1.25	1.13





### FEM Series Nipples



Body Size	Nipple Part Number	Port End	Length	Largest Diameter	Wrench Flats	Weight (lbs.)
1/4	FEM-252-4FP	1/4-18 NPSF	1.71	0.96	22mm	0.20
1/4	FEM-252-6FO	9/16-18 NPSF	1.95	0.96	22mm	0.19
3/8	FEM-372-6FP	3/8-18 NPSF	2.48	1.26	30mm	0.40
3/8	FEM-372-8FO	3/4-16 UNF	2.48	1.26	30mm	0.41
1/2	FEM-502-8FP	1/2-14 NPSF	2.77	1.38	1.25	0.54
1/2	FEM-502-8FO	3/4-16 UNF	2.77	1.38	1.25	0.54
1/2	FEM-502-10FO	7/8-14 UNF	2.77	1.38	1.25	0.54
1/2	FEM-502-12FO	1 1/16-12 UN	3.02	1.38	1.25	0.54
5/8	FEM-622-12FO	1 1/16-12 UN	3.09	1.57	36mm	0.72
3/4	FEM-752-12FP	3/4-14 NPSF	3.38	1.97	46mm	1.17
3/4	FEM-752-12FO	1-1/16 12 UN	3.38	1.97	46mm	1.20
1	FEM-1002-16FP	1-11 1/2 NPSF	3.85	2.36	55mm	1.94
1	FEM-1002-16FO	1-5/16 12 UN	3.85	2.36	55mm	1.90

### FEM Series Nipples (Bulkhead)



Body Size	Nipple Part Number	Port End	Length	Largest Diameter	Wrench Flats	Weight (lbs.)
1/2	FEM-502-10BMF	7/8-14 UNF	3.85	1.38	1.25	0.84
1/2	FEM-502-10BMS	1-14 UNS	3.85	1.38	1.25	0.84

**Standard Port Configurations:** **FP** - Female Pipe Thread **FO** - Female Straight Thread **BMF** - Bulkhead Flare **BMS** - Bulkhead Face Seal

Other Fitting Port Configurations available upon request.

### Dust Caps - FEM Series



Body Size	Nipple Dust Cap	Coupler Dust Cap	Material
1/4	CFE-252-PN	PFE-251-PN	PVC
3/8	CFE-372-PN	PFE-371-PN	PVC
1/2	CFE-502-PN	PFE-501-PN	PVC
5/8	CFE-622-PN	PFE-621-PN	PVC
3/4	CFE-7252-PN	PFE-751-PN	PVC
1	CFE-1002-PN	PFE-1001-PN	PVC

1/8"

1/4"

3/8"

1/2"

5/8"

3/4"

1"

1-1/4"

1-1/2"



### Applications

Parker FEC Series nipple provide connect-under-pressure capability with up to 3000 PSI of trapped pressure in the nipple and are ideal for applications where residual pressure makes reconnect difficult. Utilized primarily in the construction equipment market, FEC Series products are commonly found on hydraulic attachments used in skid steer applications. The FEC Series mates with the FEM Series interface ISO 16028 couplers.

### Features:

- Connect-Under-Pressure nipple
- Hardened locking surface
- Steel construction, Chromium-6 Free plating for corrosion resistance
- Anti blowout Nitrile/PTFE bonded nipple seal
- Flush face valving

### Connect Under Pressure Operation

FEC Series products operate slightly different from traditional non-spill couplings. With no pressure in the coupler and up to 3000 PSI of trapped pressure in the nipple, begin to couple the mating halves. Delay momentarily during connection to allow trapped pressure to equalize with the mating half before completing the connection.

### Performance

FEC Series (1/2", 5/8", 3/4")  
Test Fluid: Oil - 200 SUS

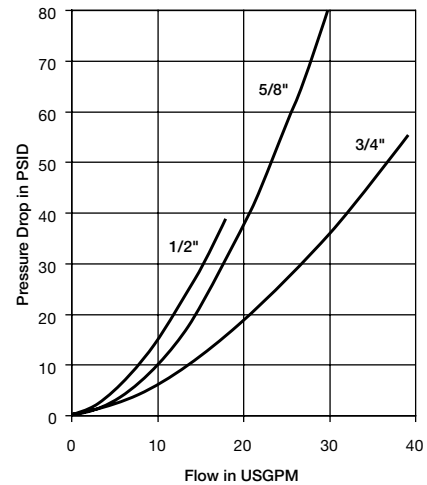

### FEC Series Specifications

Body Size	Rate Pressure (psi)	Rated Connect-Under-Pressure Capability	Rated Flow (gpm)	Spillage (ml) max. per disconnect	Air Inclusion (ml) max. per connect
1/2	3625	3000	12	.020	.070
5/8	3625	1700	20	.003	.070
3/4	3625	1500	26	.150	.100

### FEC Series Connect Under Pressure Nipples



Body Size	Part Number	Mating Half	Port End	Length	Largest Diameter	Wrench Flats	Weight (lbs.)
1/2	FEC-502-8FP	FEM-501	1/2-14 NPSF	3.50	1.22	1.125	-
1/2	FEC-502-10FO	FEM-501	7/8-14 UNF	3.50	1.22	1.125	-
1/2	FEC-502-12FO	FEM-501	1 1/16-12 UNF	3.79	1.65	1.500	-
5/8	FEC-622-12FO	FEM-621	1 1/16-12 UN	3.39	1.65	1.500	-
3/4	FEC-752-12FO	FEM-751	1 1/16-12 UN	4.84	1.65	1.500	-

Standard Port Configurations: **FP** - Female Pipe Thread **FO** - Female Straight Thread

# Catalog 3900 - Hydraulic Couplings Non-Spill Adapters

EAS/SAE Adapters  
ISO 16028 / ISO 7241-A  
1/2 inch body size



Pioneer Non-Spill Adapters were designed to accommodate the widespread use of several coupling types in mobile equipment. These adapters allow the user to adapt between poppet style, (ISO 7241-A), 6600 series couplings and non-spill type, (ISO 16028), FEM/FF series couplings. They are useful where multiple hydraulic attachments are being utilized.

### Features:

- Adapts flush, non-spill valving to / from poppet style
- Global interchangeability with other ISO 16028 and ISO 7241-A compliant couplings
- Protective zinc plating with clear trivalent chromate finish

### Applications include:

- Skid loader attachments



Quick Couplings

### Performance

FEM/FF to 6600 Adapter (1/2")  
Test Fluid: Oil - 200 SUS

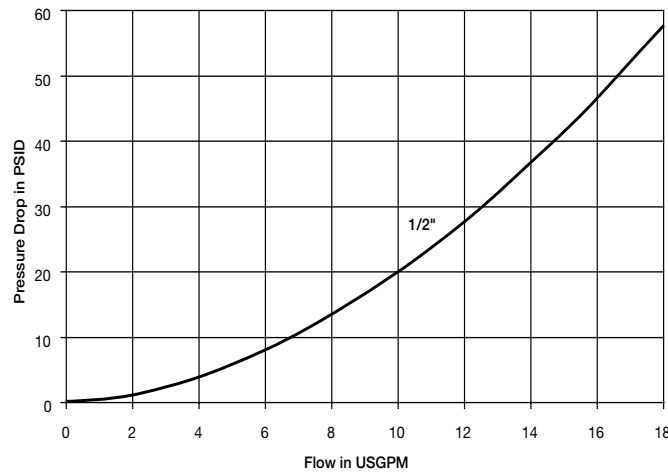

### How To Order

#### Adapter Part Number

**E A S - 500**

1/2" Body Size

Male Half of Adapter

E - FEM Series (ISO 16028 Standard)

S - 6600 Series

Adapter Series

Female Half of Adapter

E - FEM Series (ISO 16028 Standard)

S - 6600 Series

### Specifications

Body Size	Rate Pressure (psi)	Rated Flow (gpm)	Temperature Range	Spillage (ml) max. per disconnect	Air Inclusion (ml) max. per connect
1/2	3625	12	-40° to +250° F	.020	.070

### Adapters



Body Size	Part Number	Thread Size	Length	Wrench Flats	Largest Diameter
1/2	EAS-500	N/A	3.36	1.38	1.50
1/2	SAE-500	N/A	3.00	1.25	1.48

1/8"

1/4"

3/8"

1/2"

5/8"

3/4"

1"

1-1/4"

1-1/2"



FS Series dry disconnect couplings are ideal for closed system transfer and dispensing of chemicals and other fluids. The flush valves eliminate spillage and air inclusion when connecting and disconnecting to result in minimal environmental contamination.

### Features:

- Flush, non-spill valves enable ease of cleaning
- 316 stainless steel material for chemical compatibility
- Push to connect operation
- Fluorocarbon standard seal material with options available

### Applications include:

- Chemical dispensing systems
- Chemical processing
- Food processing
- Corrosive media transfer

### Materials of Construction

- Machined Parts:** Stainless Steel, AISI type 316  
**Springs:** Stainless Steel, AISI type 316.  
**Locking Balls:** 1/4" - 302 SS;  
 3/8" - 1" - Tungsten Carbide  
**Backup Washers:** PTFE  
**Elastomer Seals:** Fluorocarbon is standard.  
 Wide range is available.

Specifications					
Body Size	Rated Pressure (psi)	Rated Flow (gpm)	Spillage (ml) max. per disconnect	Air Inclusion (ml) max. per connect	CV
1/4	2000	3	.015	.010	0.90
3/8	2000	6	.015	.020	1.80
1/2	2000	12	.020	.070	3.00
3/4	2000	28	.150	.100	7.00
1	2000	50	.250	.182	10.1

Temperature Range (continuous)		
Part No. Seal Suffix	Seal Compound	Temp° F Rating
None*	Fluorocarbon	-15 to 400
E5	Ethylene Propylene (EPR)	-65 to 300
E1	Nitrile	-40 to 250
E35	Perfluoroelastomer (Contact Factory)	-20 to 600

\*Fluorocarbon is standard seal.

### Performance Flow Data

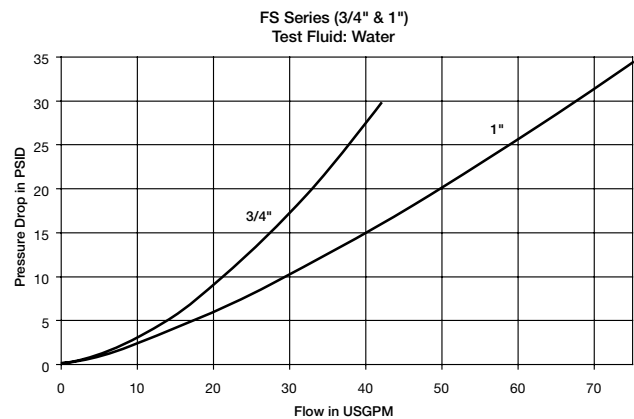
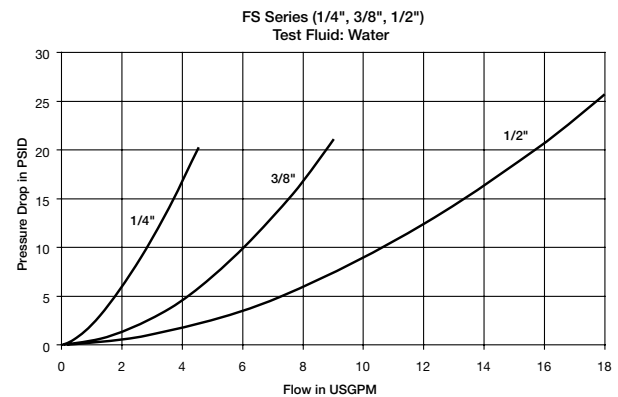



**FS Series Couplers - Female Pipe Thread**



Body Size	Coupler Part Number	Port End	Length	Largest Diameter	Wrench Flats	Weight (lbs.)
1/4	FS-251-4FP	1/4-18 NPT	1.79	1.06	1.00	0.25
1/4	FS-251-4MP	1/4-18 NPTF	2.00	1.06	1.00	0.25
1/4	FS-251-6FO	9/16-18UNF	1.92	1.06	1.00	0.24
3/8	FS-371-6FP	3/8-18 NPT	2.52	1.30	1.06	0.58
3/8	FS-371-8FO	3/4-16 UNF	2.83	1.30	1.06	0.63
1/2	FS-501-8FP	1/2-14 NPT	2.74	1.58	1.38	0.92
1/2	FS-501-10FO	7/8-14 UNF	2.86	1.58	1.38	0.96
3/4	FS-751-12FP	3/4-14 NPT	3.63	1.99	1.75	2.00
3/4	FS-751-12FO	1-1/16-12 UNF	3.73	1.99	1.75	2.04
1	FS-1001-16FP	1-11 1/2 NPT	4.14	2.25	1.87	2.76
1	FS-1001-16FO	1-15/16-12 UNF	4.24	2.25	1.87	2.80

**FS Series Nipples - Female Pipe Thread**



Body Size	Coupler Part Number	Port End	Length	Largest Diameter	Wrench Flats	Weight (lbs.)
1/4	FS-252-4FP	1/4-18 NPT	1.66	1.06	1.00	0.18
1/4	FS-252-4MP	1/4-18 NPT	1.87	1.06	1.00	0.18
1/4	FS-252-6FO	9/16-18 UNF	1.78	1.06	1.00	0.17
3/8	FS-372-6FP	3/8-18 NPT	2.31	1.08	0.94	0.26
3/8	FS-372-8FO	3/4-16 UNF	2.45	1.30	1.06	0.30
1/2	FS-502-8FP	1/2-14 NPT	2.75	1.58	1.12	0.44
1/2	FS-502-10FO	7/8-14 UNF	2.85	1.58	1.12	0.48
3/4	FS-752-12FP	3/4-14 NPT	3.38	1.99	1.50	1.02
3/4	FS-752-12FO	1-1/16-12 UNF	3.38	1.65	1.50	1.14
1	FS-1002-16FP	1-11 1/2 NPT	3.89	2.17	1.87	1.60
1	FS-1002-16FO	1-5/16 12 UNF	3.89	2.17	1.87	1.64

Standard Port Configurations: **FP** - Female Pipe Thread **MP** - Male Pipe Thread **FO** - Female Straight Thread

**Dust Caps - FS Series**



Body Size	Coupler Dust Cap-Rubber	Nipple Dust Cap-Rubber
1/4	FR-25	FR-25
3/8	NR-50	NR-37
1/2	FR-501	FR-502
3/4	FR-751	FR-752
1	FR-1001	FR-1002



**FS Series Repair Kits**

Repair kits are available for both coupler and nipple half of FS coupling. Kits include replacement elastomer seals, valve assembly and instructions to perform rebuild. Spline tool must be ordered separately to accomplish coupler half repair. Other tools required: Vise, Allen Wrench and Open End Wrench.

FS Repair Kits		
<b>TOOL Spline tool for Coupler Repair</b>	Replacement Seals	
	No Suffix	Fluorocarbon Seals
	<b>E5</b>	Ethylene Propylene (EPR)
	<b>E35</b>	Perfluoroelastomer (Contact Factory for Seal Options).

Nipple Repair Kits			
1/4	FS-252-KIT	FS-252-KIT-E5	-
3/8	FS-372-KIT	FS-372-KIT-E5	-
1/2	FS-502-KIT	FS-502-KIT-E5	-
3/4	FS-752-KIT	FS-752-KIT-E5	-
1	FS-1002-KIT	FS-1002-KIT-E5	-

Coupler Repair Kits			
1/4	N/A	N/A	N/A
3/8	FS 371-KIT	FS 371-ES	FF/FS 371-TOOL
1/2	FS-501-KIT	FS-501-KIT-E5	FS-501-TOOL
3/4	FS-751-KIT	FS-751-KIT-E5	FF/FS-751-TOOL
1	FS-1001-KIT	FS-1001-KIT-E5	FF/FS-751-TOOL





PF Series dry disconnect couplings are ideal for closed system transfer and dispensing of chemicals and other fluids. The flush valves eliminate spillage and air inclusion when connecting and disconnecting to result in minimal environmental contamination.

### Features:

- Flush, non-spill valves enable ease of cleaning
- Rugged glass filled polypropylene construction for chemical compatibility
- Fluorocarbon seals
- Push to connect operation
- 1" coupler has non-wetted springs

### Applications include:

- Chemical dispensing systems
- Spray application equipment
- Mini bulk tanks
- Replacement for banjo style camlok fittings & ball valves
- Bulk transfer barrels

### Performance

PF (1/2", 1", 2")  
Test Fluid: Water

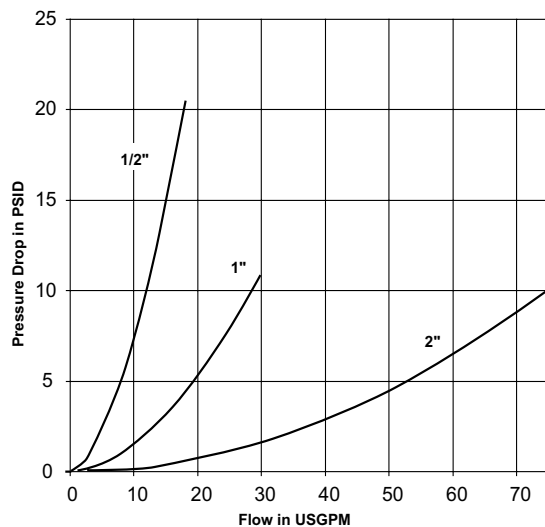

### FC Series Specifications

Body Size (in.)	Materials:			Rated Pressure (psi at 68°)	Rated Flow (gpm)	Pressure Drop at Rated Flow	Maximum Force to Connect	Maximum Force Disconnect	Operating Temperature/ Storage Temperature	Spillage max. per disconnect	Vacuum Rating
	Body	Springs	Seals								
1/2	Polypropylene	316 Stainless Steel	Fluorocarbon	100	12	11.3 PSI	32 lbs.	12 lbs.	+40° to +140° -20° to +140° F	0.14 ml .01 cu. in.	27.4 Hg
1				60	20	3.4 PSI	41 lbs.	17 lbs.		1 ml .06 cu. in. (1cc)	N/A
2				100	50	4 PSI	54	17 lbs.		9 ml .5 cu. in.	N/A

1/8"

1/4"

3/8"

1/2"

5/8"

3/4"

1"

1-1/4"

1-1/2"



**PF Series Couplers**



Body Size	Coupler Part Number	Port End	Length	Largest Diameter	Wrench Flats	Weight (lbs.)
1/2	PF-501-8FP	1/2" NPT	3.02	1.88	1.38	0.17
1	PF-1001-16FP	1" NPT	3.59	3.0	1.99	0.53
2	PF-2001-32FP	2" NPT	6.63	5.00	-	1.75

**PF Series Nipples**



Body Size	Coupler Part Number	Port End	Length	Largest Diameter	Wrench Flats	Weight (lbs.)
1/2	PF-502-8FP	1/2" NPT	2.96	1.33	1.24	0.08
1	PF-1002-16FP	1" NPT	3.92	2.20	1.87	0.26
2	PF-2002-32FP	2" NPT	5.71	3.55	-	0.75

**PF Series Nipples - Tank Mount**



Body Size	Coupler Part Number	Port End	Tank Mount Thread	Length	Largest Diameter	Wrench Flats	Weight (lbs.)
1	PF-1002-32MB	1" NPT	Modified Buttress	3.92	2.75	1.87	0.33
1	PF-1002-32MP	1" NPT	Modified NPS	3.92	2.75	1.87	0.31



Coupler Dust Cap  
FR-501

Nipple Dust Cap  
FR-502

Nipple Dust Cap  
PFR-1002



Nipple Dust Cap  
(Tank Mount)  
PFR-1002-NS

**PF Series - Dust Cap and Plugs**

Body Size	Coupler Dust Cap Part Number	Nipple Dust Cap Part Number	Material
1/2	FR-501	FR-502	Synthetic Rubber
1	None	PFR-1002	Ethylene Propylene
1	None	PFR-1002-NS*	Ethylene Propylene

\* For use with Tank Mount Nipples



ST Series non-valved couplings provide maximum flow and low pressure drop. The smooth, open bore allows easy cleaning in applications where the same lines are used for more than one media.

### Features

- Steel nipples are case hardened for resistance to Brinelling
- Functionally interchanges with similar straight-through design couplings
- Standard Nitrile seals
- Material options available

### Applications:

- High pressure water
- Steam washers
- Carpet cleaners



Specifications					
Body Size	Rated Pressure (psi) Brass Coupler/Nipple	Rated Pressure (psi) Brass Coupler/Steel Nipple	Rated Pressure (psi) SS Coupler/Nipple	Temperature Range (standard seals)	Rated Flow
1/8"	2500	2600	4200	-40° to +250° F	3
1/4"	5200	5500	6700		6
3/8"	2700	3500	5500		12
1/2"	2200	2700	3000		12
3/4"	1700	2700	3000		28
1"	1200	2000	1700		50
1-1/4"	1700	-	-		76
1-1/2"	1400	-	-		100

### Performance

ST Series (1/8", 1/4", 3/8", 1/2")  
Test Fluid: Oil - 150 SUS

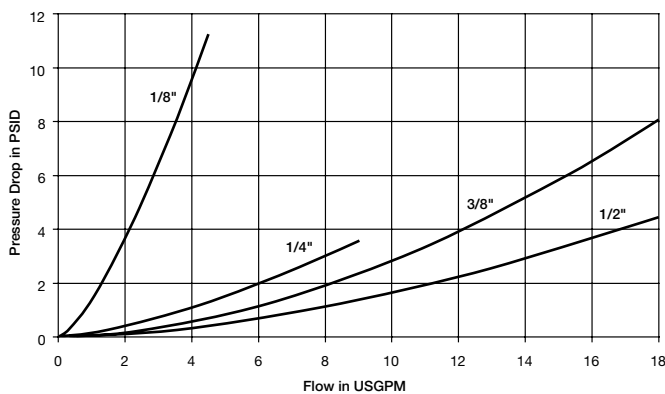

ST Series (3/4", 1", 1-1/4")  
Test Fluid: Oil - 150 SUS

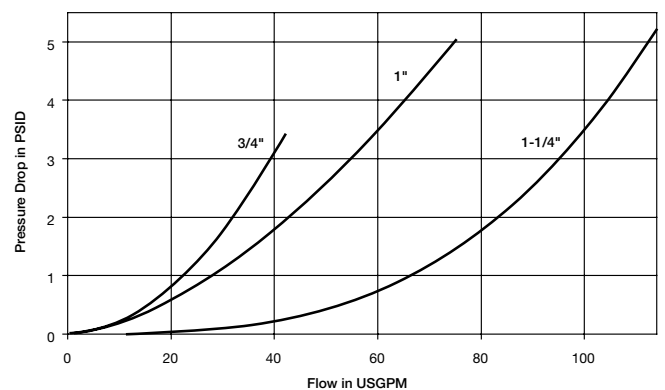



**ST Series Couplers - Female Pipe Thread**



Body Size	Brass Part Number	303 Stainless Part Number	Port End	Length	Largest Diameter	Wrench Flats	Brass Weight (lbs.)	Stainless Weight (lbs.)
1/8	BST-1	SST-1	1/8-27 NPTF	1.06	0.69	0.56	0.06	0.05
1/4	BST-2	SST-2	1/4-18 NPTF	1.54	0.94	0.81	0.17	0.15
3/8	BST-3	SST-3	3/8-18 NPTF	1.64	1.16	1.00	0.26	0.24
1/2	BST-4	SST-4	1/2-14 NPTF	1.98	1.30	1.13	0.59	0.37
3/4	BST-6	SST-6	3/4-14 NPTF	2.15	1.66	1.44	0.62	0.57
1	BST-8	SST-8	1-11 1/2 NPTF	2.43	2.02	1.75	0.99	0.93
1-1/4	BST-10	-	1 1/4-11 1/2 NPTF	2.44	2.51	2.00	1.38	-
1-1/2	BST-12	-	1 1/2-11 1/2 NPTF	2.88	3.00	2.50	2.43	-

**ST Series Couplers - Male Pipe Thread**



Body Size	Brass Part Number	303 Stainless Part Number	Port End	Length	Largest Diameter	Wrench Flats	Brass Weight (lbs.)	Stainless Weight (lbs.)
1/8	BST-1M	SST-1M	1/8-27 NPTF	1.06	0.69	0.56	0.05	0.05
1/4	BST-2M	SST-2M	1/4-18 NPTF	1.69	0.94	0.81	0.13	0.16
3/8	BST-3M	SST-3M	3/8-18 NPTF	1.75	1.16	1.00	0.25	1.16
1/2	BST-4M	SST-4M	1/2-14 NPTF	1.94	1.30	1.13	0.34	1.30
3/4	BST-6M	SST-6M	3/4-14 NPTF	2.17	1.66	1.44	-	1.66
1	BST-8M	SST-8M	1-11 1/2 NPTF	2.53	2.02	1.75	0.85	2.02



### ST Series Nipples- Female Pipe Thread



Body Size	Brass Part Number	Weight. (lbs.)	Steel Part Number	Weight. (lbs.)	303 Stainless Part Number	Weight. (lbs.)	Length	Largest Diameter	Wrench Flats
1/8	BST-N1	0.03	ST-N1	0.03	SST-N1	0.02	0.98	0.65	0.56
1/4	BST-N2	0.07	ST-N2	0.07	SST-N2	0.07	1.46	0.87	0.75
3/8	BST-N3	0.12	ST-N3	0.11	SST-N3	0.11	1.62	1.59	0.08
1/2	BST-N4	0.23	ST-N4	0.21	SST-N4	0.21	1.85	1.30	1.13
3/4	BST-N6	0.33	ST-N6	0.32	SST-N6	0.32	2.15	1.59	1.38
1	BST-N8	0.52	ST-N8	0.49	SST-N8	0.48	2.35	1.88	1.63
1-1/4	BST-N10	0.85	-	-	-	-	2.38	2.31	2.00
1-1/2	BST-N12	1.45	-	-	-	-	2.81	2.74	2.38

### ST Series Nipples- Male Pipe Thread



Body Size	Brass Part Number	Weight. (lbs.)	Steel Part Number	Weight. (lbs.)	303 Stainless Part Number	Weight. (lbs.)	Length	Largest Diameter	Wrench Flats
1/8	BST-N1M	0.02	ST-N1	0.02	SST-N1	0.02	1.04	0.51	0.44
1/4	BST-N2M	0.06	ST-N2	0.05	SST-N2	0.05	1.53	0.65	0.56
3/8	BST-N3M	0.08	ST-N3	0.07	SST-N3	0.08	1.69	0.79	0.69
1/2	BST-N4M	0.15	ST-N4	0.13	SST-N4	0.13	1.94	1.01	0.88
3/4	BST-N6M	0.23	ST-N6	0.21	SST-N6	0.22	2.19	1.23	1.06
1	BST-N8M	0.46	ST-N8	0.43	SST-N8	0.43	2.51	1.59	1.38
1-1/4	BST-N10M	0.96	-	-	-	-	2.85	2.17	1.88
1-1/2	BST-N12M	1.46	-	-	-	-	3.25	2.45	2.13





Pioneer Water Service Quick Couplings add convenience and efficiency wherever water hoses are frequently connected and disconnected. The durable 4-ball locking mechanism provides a secure connection.

**Features:**

- Brass and stainless steel construction
- Nitrile seals

**Applications include:**

- Garden hoses
- Wash down systems
- Mobile water tank lines

Specifications			
Body Size	Rated Pressure (psi)	Rated Flow (gpm)	Temperature Range (std seals)
3/4	200	28	-40° to +250° F

Coupler					
Body Size	Coupler Part Number	Port End	Length	Largest Diameter	Weight (lbs.)
3/4	1163-60	3/4-11 1/2 NH	1.16	1.21	0.12

Nipple					
Body Size	Coupler Part Number	Port End	Overall Length	Exposed Length	Weight (lbs.)
3/4	1163-61	3/4-11 1/2 NH	1.25	0.50	0.08



Pioneer Industrial Interchange Nipples are compatible for use with 20 Series, HF Series, Universal or E-z-mate couplers. The standard male tip of the pneumatic industry, these nipples are interchangeable with similar nipples manufactured to the same requirements.

**Features:**

- Conforms to A-A-59439 (MIL-C-4109F, ISO 6150-B) requirements for global interchangeability
- Hardened wear points and load-bearing areas
- Unvalved style nipple mates with valved couplers

**Applications include:**

- Air compressors
- Pneumatic tools
- Drop-down air lines

### Nipples- Female Pipe Thread



Body Size	Part Number Brass	Part Number Steel	Port End	Length	Largest Diameter	Wrench Flats	Weight (lbs.)
1/4	-	H1C	1/8-27 NPTF	1.48	0.58	0.50	0.03
1/4	BH3C	H3C	1/4-18 NPTF	1.56	0.72	0.62	0.05
1/4	-	H3C-E	3/8-18 NPTF	1.60	0.94	0.81	0.08
3/8	-	H1E	1/4-18 NPTF	1.60	0.72	0.62	0.06
3/8	BH3E	H3E	3/8-18 NPTF	1.69	0.94	0.81	0.10
3/8	-	H3E-F	1/2-14 NPTF	1.84	1.16	1.00	0.13
1/2	-	H1F	3/8-18 NPTF	2.03	0.94	0.81	0.12
1/2	BH3F	H3F	1/2-14 NPTF	2.20	1.16	1.00	0.19
1/2	-	H3F-G	3/4-14 NPTF	2.30	1.44	1.25	0.26
3/4	-	H3G-F	1/2-14 NPTF	2.22	1.16	1.00	0.23
3/4	-	H3G	3/4-14 NPTF	2.18	1.44	1.25	0.34
3/4	-	H3G-J	1-11 1/2 NPTF	2.41	1.80	1.63	0.47





**Nipples- Male Pipe Thread**



Body Size	Part Number Brass	Part Number Steel	Port End	Length	Largest Diameter	Wrench Flats	Weight (lbs.)
1/4	-	H0C	1/8-27 NPTF	1.68	0.58	0.50	0.05
1/4	BH2C	H2C	1/4-18 NPTF	1.66	0.65	0.56	0.06
1/4	-	H2C-E	3/8-18 NPTF	1.90	0.80	0.69	0.07
3/8	-	H00E	1/8-27 NPTF	1.68	0.72	0.62	0.08
3/8	-	H0E	1/4-18 NPTF	1.90	0.72	0.62	0.08
3/8	BH2E	H2E	3/8-18 NPTF	1.90	0.80	0.69	0.09
3/8	-	H2E-F	1/2-14 NPTF	2.03	1.02	0.88	0.15
1/2	-	H0F	3/8-18 NPTF	2.20	0.79	0.69	0.16
1/2	BH2F	H2F	1/2-14 NPTF	2.35	1.01	0.88	0.18
1/2	-	H2F-G	3/4-14 NPTF	2.40	1.22	1.06	0.24
3/4	-	H2G-F	1/2-14 NPTF	2.32	1.16	1.00	0.22
3/4	BH2G	H2G	3/4-14 NPTF	2.28	1.22	1.06	0.28
3/4	-	H2G-J	1-11 1/2 NPTF	2.56	1.52	1.31	0.36

**Nipples- Standard Hose Barb**



Body Size	Part Number Steel	Hose I.D.	Length	Largest Diameter	Weight (lbs.)
1/4	H8C	1/4	1.72	0.46	0.04
1/4	H8C-D	5/16	1.96	0.50	0.04
1/4	H9C	3/8	1.96	0.50	0.05
3/8	H5E	3/8	1.85	0.59	0.07
3/8	H6E	1/2	2.09	0.68	0.08
1/2	H4F	3/8	2.36	0.66	0.10
1/2	H5F	1/2	2.36	0.66	0.11
1/2	H5F-G	3/4	2.95	0.87	0.18
3/4	H5G-F	1/2	2.47	0.93	0.19
3/4	H5G	3/4	3.00	0.93	0.25
3/4	H5G-J	1	3.24	1.24	0.36

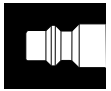

**Nipples- Push-Lok Hose Barb\***



Body Size	Part Number Steel	Hose I.D.	Length	Largest Diameter	Weight (lbs.)
1/4	H8CP	1/4	1.74	0.69	0.04
1/4	H9CP	3/8	1.96	0.86	0.05
3/8	H4EP	1/4	1.87	0.69	0.06
3/8	H5EP	3/8	2.02	0.86	0.07
3/8	H6EP	1/2	2.21	0.97	0.09
1/2	H4FP	3/8	2.36	0.86	0.11
1/2	H5FP	1/2	2.48	0.97	0.11
1/2	H6FP	5/8	2.95	1.14	0.14

\* Push-Lok hose barbs are designed for use with Parker Push-Lok hose and do not require clamps.





20 Series Pneumatic Couplers mate with Industrial Interchange nipples, the standard male tip of the pneumatic industry. Available options include Sleeve-Lok, stainless steel locking balls and springs, and grip-ring sleeve.

### Features:

- Mates with Industrial Interchange nipples manufactured to A-A-59439 (MIL-C-4109F, ISO 6150-B) global standards
- 1/4" body size has a brass body and steel valve, 3/8" body size has all steel construction
- Standard seal is Nitrile

### Applications:

- Air compressors
- Pneumatic tools
- Water
- Grease
- Paint

**Performance** 20 Series (1/4", 3/8", 1/2" sizes)

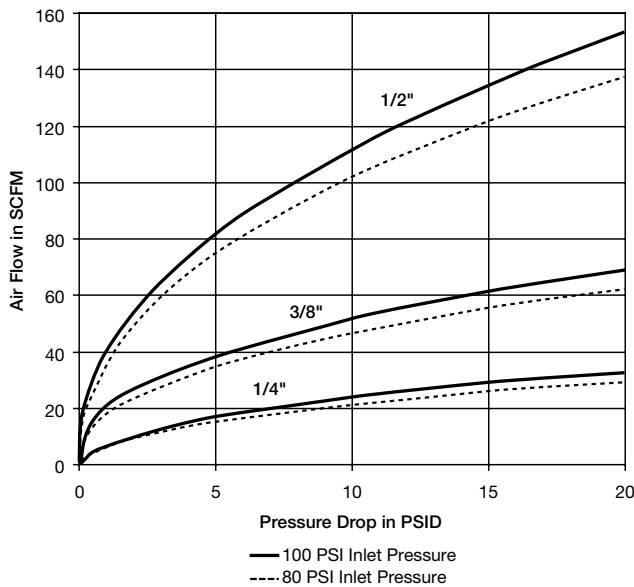

### 20 Series Specifications

Body Size	Rate Pressure (psi)	Temperature Range (standard seals)	Locking Device	Vacuum Data (in. hg)	Disconnected (coupler only)	Connected
1/4	300	-40° to +250° F	4 balls	-	<b>Not Recommended</b>	27.4
3/8	300		8 balls	-		27.4
1-2	300		8 balls	-		27.4



### Couplers- Female Pipe Thread



Body Size	Part Number Brass	Part Number Steel	Port End	Length	Largest Diameter	Wrench Flats	Weight (lbs.)
1/4	B23A	-	1/8-27 NPTF	1.83	0.90	0.75	0.20
1/4	B23	-	1/4-18 NPTF	1.83	0.90	0.75	0.19
1/4	B23E	-	3/8-18 NPTF	1.95	0.94	0.81	0.20
3/8	-	25C	1/4-18 NPTF	2.22	1.06	0.88	0.30
3/8	B25	25	3/8-18 NPTF	2.28	1.06	0.88	0.32
3/8	-	25F	1/2-14 NPTF	2.55	1.16	1.00	0.34
1/2	-	17E	3/8-18 NPTF	2.74	1.19	1.00	0.46
1/2	B17	17	1/2-14 NPTF	2.96	1.19	1.00	0.50
1/2	-	17G	3/4-14 NPTF	3.19	1.44	1.25	0.56

### Couplers- Male Pipe Thread



Body Size	Part Number Brass	Part Number Steel	Port End	Length	Largest Diameter	Wrench Flats	Weight (lbs.)
1/4	B22A	-	1/8-27 NPTF	1.89	0.90	0.75	0.20
1/4	B22	-	1/4-18 NPTF	2.05	0.90	0.75	0.19
1/4	B22E	-	3/8-18 NPTF	2.08	0.94	0.75	0.20
3/8	-	24C	1/4-18 NPTF	2.36	1.06	0.88	0.30
3/8	B24	24	3/8-18 NPTF	2.39	1.06	0.88	0.32
3/8	-	24F	1/2-14 NPTF	2.55	1.16	0.88	0.34
1/2	-	16E	3/8-18 NPTF	2.93	1.19	1.00	0.46
1/2	B16 *	16	1/2-14 NPTF	3.08	1.19	1.00	0.50
1/2	-	16G	3/4-14 NPTF	3.21	1.30	1.13	0.56

\* Coupler has brass body and steel sleeve.





**Couplers- Standard Hose Barb**



Body Size	Part No. Brass	Part No. Steel	Hose I.D.	Length	Largest Diameter	Wrench Flats	Weight (lbs.)
1/4	B20-3B	-	1/4	2.49	0.90	0.75	0.18
1/4	B20-4B	-	5/16	2.49	0.90	0.75	0.18
1/4	B20-5B	-	3/8	2.49	0.90	0.75	0.18
3/8	-	24-5B	3/8	2.86	1.06	0.88	0.27
3/8	-	24-6B	1/2	3.08	1.06	0.88	0.28
1/2	-	16-5B	3/8	3.37	1.19	1.00	0.41
1/2	-	16-6B	1/2	3.62	1.19	1.00	0.43
1/2	-	16-7B	3/4	3.96	1.19	1.00	0.48

**Couplers- Push-Lok Hose Barb**



Body Size	Part No. Brass	Part No. Steel	Hose I.D.	Length	Largest Diameter	Wrench Flats	Weight (lbs.)
1/4	B20-3BP	-	1/4	2.32	0.90	0.75	0.18
1/4	B20-4BP	-	3/8	2.47	0.90	0.75	0.19
3/8	-	24-5BP	3/8	2.86	1.06	0.88	0.27
1/2	-	16-5BP	3/8	3.37	1.19	1.00	0.41
1/2	-	16-6BP	1/2	3.62	1.19	1.00	0.43

\* Push-Lok hose barbs are designed for use with Parker Push-Lok hose and do not require clamps.

NOTE: See Table of Contents for pneumatic Industrial Interchange nipples used with 20 Series couplers.





RF Series Pneumatic Couplers are designed to increase flow and reduce pressure drop through the coupling. RF nipples have up to 2-1/2 times larger flow area than standard industrial interchange nipples. The increased flow results in greater tool efficiency and decreased air costs.

### Features:

- Aerodynamic valve design.
- Flow rates on 1/4" is greater than many 3/8" body size couplers.
- Flow rates on 1/4" greater than many 3/8" body size couplers.
- Flow rates on 3/8" greater than many 1/2" body size couplers.
- Integral sleeve guard protects against accidental disconnection
- Functionally interchanges with a common high-flow European design

### Applications include:

- Air compressors
- Pneumatic tools
- Drop-down air lines

### Performance

RF Series (1/4" & 3/8" body size)  
with 1/4" & 3/8" Female NPSF

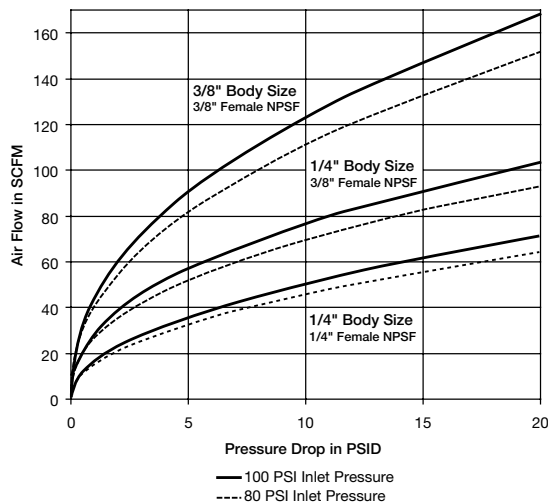

### How To Order

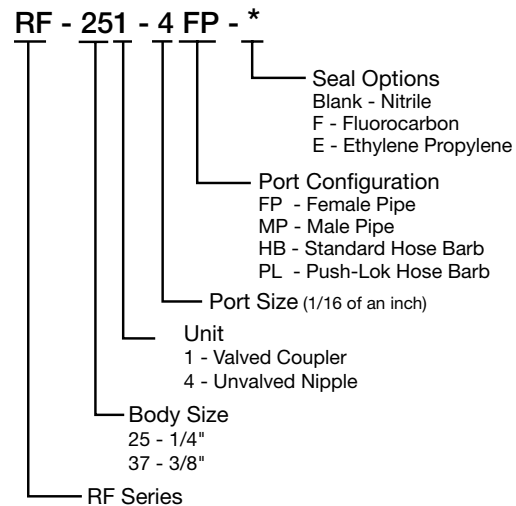

RF Series Specifications						
Body Size	Rated Pressure (psi)	Temperature Range (standard seals)	Locking Device)	Vacuum Data (in. HG)	Disconnected (coupler only)	Connected
1/4	300	-40° to +250° F	4 balls	-	Not Recommended	Not Recommended
3/8			8 balls	-		





**Couplers- Female Pipe Thread**



Body Size	Part No.	Port End	Length	Largest Diameter	Wrench Flats	Weight (lbs.)
1/4	RF-251-4FP	1/4-18 NPSF	2.19	0.99	0.81	0.26
1/4	RF-251-6FP	3/8-18 NPSF	2.34	0.99	0.81	0.27
3/8	RF-371-6FP	3/8-18 NPSF	2.33	1.07	0.94	0.31
3/8	RF-371-8FP	1/2-14 NPSF	2.49	1.07	1.00	0.35

**Couplers- Male Pipe Thread**



Body Size	Part No.	Port End	Length	Largest Diameter	Wrench Flats	Weight (lbs.)
1/4	RF-251-4MP	1/4-18 NPTF	2.34	0.99	0.81	0.24
1/4	RF-251-6MP	3/8-18 NPTF	2.37	0.99	0.81	0.25
1/4	RF-251-8MP	1/2-14 NPTF	2.56	0.99	0.88	0.29
3/8	RF-371-6MP	3/8-18 NPTF	2.52	1.07	0.94	0.30
3/8	RF-371-8MP	1/2-14 NPTF	2.68	1.07	0.94	0.33

**Couplers- Standard Hose Barb**



Body Size	Part No.	Hose I.D.	Length	Largest Diameter	Wrench Flats	Weight (lbs.)
1/4	RF-251-4HB	1/4	2.81	0.99	0.81	0.26
1/4	RF-251-6HB	3/8	2.81	0.99	0.81	0.27
3/8	RF-371-6HB	3/8	3.02	1.07	0.94	0.31
3/8	RF-371-8HB	1/2	3.02	1.07	0.94	0.34

**Couplers- Push-Lok Hose Barb**



Body Size	Part No.	Hose I.D.	Length	Largest Diameter	Wrench Flats	Weight (lbs.)
1/4	RF-251-4PL	1/4	2.64	0.99	0.81	0.26
1/4	RF-251-6PL	3/8	2.78	0.99	0.81	0.27
1/4	RF-251-8PL	1/2	2.93	0.99	0.81	0.28
3/8	RF-371-6PL	3/8	3.02	1.07	0.94	0.33
3/8	RF-371-8PL	1/2	3.02	1.07	0.94	0.33



**Nipples- Female Pipe Thread**



Body Size	Part No.	Port End	Length	Largest Diameter	Wrench Flats	Weight (lbs.)
1/4	RF-254-4FP	1/4-18 NPTF	1.45	0.72	0.62	0.06
1/4	RF-254-6FP	3/8-18 NPTF	1.50	0.94	0.81	0.09
3/8	RF-374-6FP	3/8-18 NPTF	1.53	0.94	0.81	0.10
3/8	RF-374-8FP	1/2-14 NPTF	1.62	1.16	1.00	0.13

**Nipples- Male Pipe Thread**



Body Size	Part No.	Port End	Length	Largest Diameter	Wrench Flats	Weight (lbs.)
1/4	RF-254-4MP	1/4-18 NPTF	1.60	0.65	0.56	0.05
1/4	RF-254-6MP	3/8-18 NPTF	1.67	0.75	0.69	0.08
1/4	RF-374-6MP	3/8-18 NPTF	1.70	0.75	0.69	0.09
3/8	RF-374-8MP	1/2-14 NPTF	1.85	1.01	0.88	0.15

**Nipples- Standard Hose Barb**



Body Size	Part No.	Hose I.D.	Length	Largest Diameter	Weight (lbs.)
1/4	RF-254-4HB	1/4	1.66	0.50	0.04
1/4	RF-254-6HB	3/8	1.66	0.50	0.05
3/8	RF-374-6HB	3/8	1.63	0.59	0.07
3/8	RF-374-8HB	1/2	1.97	0.68	0.08

**Nipples- Push-Lok Hose Barb**



Body Size	Part No.	Hose I.D.	Length	Largest Diameter	Weight (lbs.)
1/4	RF-254-4PL	1/4	1.69	0.50	0.04
1/4	RF-254-6PL	3/8	1.83	0.50	0.05
1/4	RF-374-6PL	3/8	1.80	0.59	0.07
3/8	RF-374-8PL	1/2	2.09	0.897	0.09





HF Series Pneumatic Quick Couplers connect with Industrial Interchange nipples, the standard male tip of the pneumatic industry. Couplers have brass construction, a corrosion resistant valve, stainless steel locking balls and a stainless valve spring.

### Features:

- Sleeve guard protects against accidental disconnection
- Push-to-connect operation
- Slim profile
- Optional heavy duty version in solid steel

### Applications include:

- Air compressors
- Pneumatic tools
- Drop-down air lines

### Performance

HF Series (1/8" & 1/4" sizes)

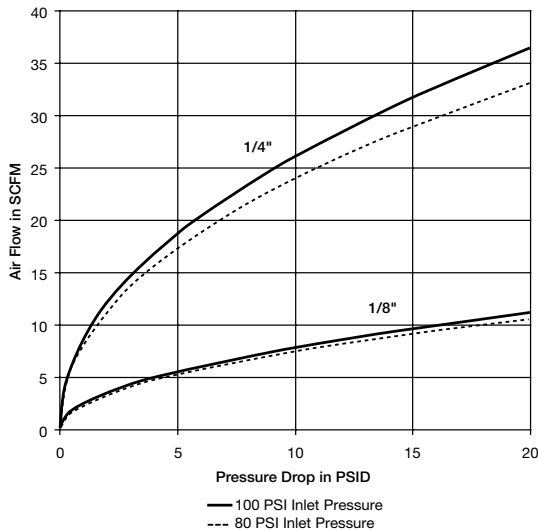

HF Series (3/8" & 1/2" sizes)

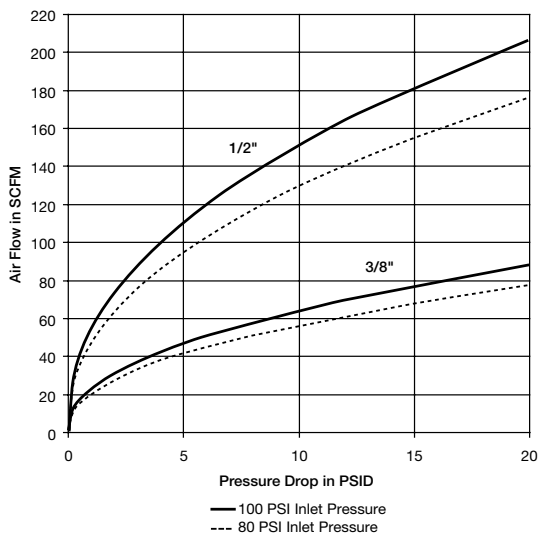

### HF Series Specifications

Body Size	1/4"	3/8"	1/2"	3/4"
Rated Pressure (psi)	250	300	300	300
Temperature Range (std seals)	-40° to +250° F			
Locking Device	5 balls	4 balls	6 balls	8 balls
Force required to connect (lbs.)	Less than 10			
<b>Vacuum Data (in. Hg.)</b>				
Disconnected (coupler only)	<b>Not Recommended</b>			
Connected	—	27.4	27.4	27.4

### How To Order

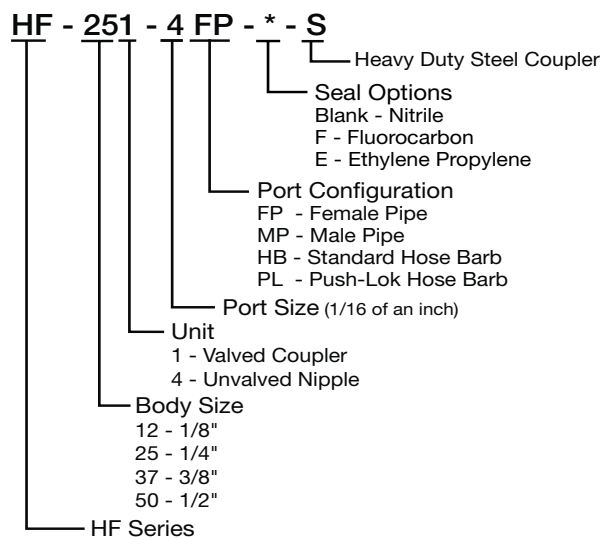



**1/8" Body Size Couplers - Female Pipe Thread**



Body Size	Part No. Brass	Port End	Length	Largest Diameter	Wrench Flats	Weight (lbs.)
1/8	HF-121-2FP	1/8-27 NPTF	1.42	0.63	0.55	0.06
1/8	HF-121-4FP	1/4-18 NPTF	1.81	0.63	0.67	0.10

**1/8" Body Size Couplers - Male Pipe Thread**



Body Size	Part No. Brass	Port End	Length	Largest Diameter	Wrench Flats	Weight (lbs.)
1/8	HF-121-2MP	1/8-27 NPTF	1.50	0.63	0.55	0.06
1/8	HF-121-4MP	1/4-18 NPTF	1.61	0.63	0.55	0.07

**1/8" Body Size Nipples - Female Pipe Thread**



Body Size	Part No. Brass	Port End	Length	Largest Diameter	Wrench Flats	Weight (lbs.)
1/8	HF-124-2FP	1/8-27 NPTF	1.08	0.58	0.50	0.03
1/8	HF-124-4FP	1/4-18 NPTF	1.34	0.78	0.67	0.07

**1/8" Body Size Nipples - Male Pipe Thread**



Body Size	Part No. Brass	Port End	Length	Largest Diameter	Wrench Flats	Weight (lbs.)
1/8	HF-124-2MP	1/8-27 NPTF	1.06	0.51	0.44	0.03
1/8	HF-124-4MP	1/4-18 NPTF	1.25	0.63	0.56	0.05





1/4, 3/8, 1/2" Body Size Couplers - Female Pipe Thread



Body Size	Part No. Brass	Port End	Length	Largest Diameter	Wrench Flats	Weight (lbs.)
1/4	HF-251-4FP	1/4-18 NPSF	2.19	0.99	0.81	0.26
1/4	HF-251-6FP	3/8-18 NPSF	2.34	0.99	0.81	0.27
3/8	HF-371-4FP	1/4-18 NPSF	2.33	1.07	0.94	0.33
3/8	HF-371-6FP	3/8-18 NPSF	2.33	1.07	0.94	0.31
3/8	HF-371-8FP	1/2-14 NPSF	2.49	1.07	1.00	0.35
1/2	HF-501-8FP	1/2-14 NPSF	3.35	1.19	1.06	0.60

1/4, 3/8, 1/2" Body Size Couplers - Male Pipe Thread



Body Size	Part No. Brass	Port End	Length	Largest Diameter	Wrench Flats	Weight (lbs.)
1/4	HF-251-4MP	1/4-18 NPTF	2.34	0.99	0.81	0.25
1/4	HF-251-6MP	3/8-18 NPTF	2.37	0.99	0.81	0.26
3/8	HF-371-4MP	1/4-18 NPTF	2.49	1.07	0.94	0.32
3/8	HF-371-6MP	3/8-18 NPTF	2.52	1.07	0.94	0.3
3/8	HF-371-8MP	1/2-14 NPTF	2.68	1.07	0.94	0.33
1/2	HF-501-8MP	1/2-14 NPTF	3.48	1.19	1.06	0.57

1/4, 3/8, 1/2" Body Size Couplers - Standard Hose Barb



Body Size	Part No. Brass	Hose I.D.	Length	Largest Diameter	Wrench Flats	Weight (lbs.)
1/4	HF-251-4HB	1/4	2.81	0.99	0.81	0.26
1/4	HF-251-6HB	3/8	2.81	0.99	0.81	0.27
3/8	HF-371-6HB	3/8	3.02	1.07	0.94	0.31
3/8	HF-371-8HB	1/2	3.02	1.07	0.94	0.34

1/4, 3/8, 1/2" Body Size Couplers - Push-Lok Hose Barb



Body Size	Part No. Brass	Hose I.D.	Length	Largest Diameter	Wrench Flats	Weight (lbs.)
1/4	HF-251-4PL	1/4	2.64	0.99	0.81	0.26
1/4	HF-251-6PL	3/8	2.78	0.99	0.81	0.27
3/8	HF-371-6PL	3/8	3.02	1.07	0.94	0.33
3/8	HF-371-8PL	1/2	3.07	1.07	0.94	0.31



**Heavy Duty Couplers - Female Pipe Thread**



Body Size	Part No. Steel	Port End	Length	Largest Diameter	Wrench Flats	Weight (lbs.)
1/4	HF-251-4FP-S	1/4-18 NPTF	2.19	0.99	0.81	0.26
1/4	HF-251-6FP-S	3/8-18 NPTF	2.34	0.99	0.81	0.27
3/8	HF-371-4FP-S	1/4-18 NPTF	2.33	1.07	0.94	0.33
3/8	HF-371-6FP-S	3/8-18 NPTF	2.33	1.07	0.94	0.31
3/8	HF-371-8FP-S	1/2-14 NPTF	2.49	1.07	1.00	0.35

**Heavy Duty Couplers - Male Pipe Thread**



Body Size	Part No. Steel	Port End	Length	Largest Diameter	Wrench Flats	Weight (lbs.)
1/4	HF-251-4MP-S	1/4-18 NPTF	2.34	0.99	0.81	0.25
1/4	HF-251-6MP-S	3/8-18 NPTF	2.37	0.99	0.81	0.26
3/8	HF-371-4MP-S	1/4-18 NPTF	2.49	1.07	0.94	0.32
3/8	HF-371-6MP-S	3/8-18 NPTF	2.52	1.07	0.94	0.30
3/8	HF-371-8MP-S	1/2-14 NPTF	2.68	1.07	0.94	0.33

**Heavy Duty Couplers - Standard Hose Barb**



Body Size	Part No. Steel	Hose I.D.	Length	Largest Diameter	Wrench Flats	Weight (lbs.)
1/4	HF-251-4HB-S	1/4	2.81	0.99	0.81	0.26
1/4	HF-251-6HB-S	3/8	2.81	0.99	0.81	0.27
3/8	HF-371-6HB-S	3/8	3.02	1.07	0.94	0.31
3/8	HF-371-8HB-S	1/2	3.02	1.07	0.94	0.34

**Heavy Duty Couplers - Push-Lok Hose Barb**



Body Size	Part No. Steel	Hose I.D.	Length	Largest Diameter	Wrench Flats	Weight (lbs.)
1/4	HF-251-4PL-S	1/4	2.64	0.99	0.81	0.26
1/4	HF-251-6PL-S	3/8	2.78	0.99	0.81	0.27
3/8	HF-371-6PL-S	3/8	3.02	1.07	0.94	0.33
3/8	HF-371-8PL-S	1/2	3.07	1.07	0.94	0.31



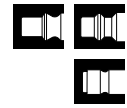

UC Series Pneumatic Quick Couplers connect with Industrial Interchange, 10 series (Tru-Flate), and 50 series (ARO 210) style nipples. While the best performance is obtained by matching like series couplers and nipples, the Universal Coupler permits multiple series nipples to mate with one coupler.

### Features:

- Sleeve guard protects against accidental disconnection
- Push-to-connect operation
- Brass construction
- One coupler connects with three nipple styles

### Applications include:

- Air compressors
- Pneumatic tools
- Drop-down air lines

### Performance

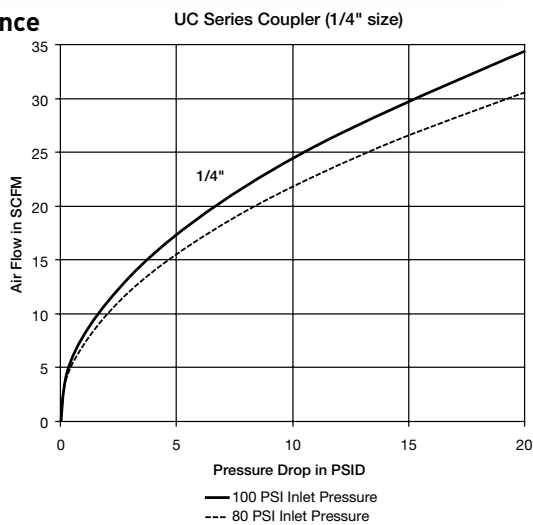

### UC Series Specifications

Body Size	Rated Pressure (psi)	Temperature Range (Nitrile seats)	Locking Device	Vacuum Service
1/4	150	-40° to +250° F	4 balls	<b>Not Recommended</b>

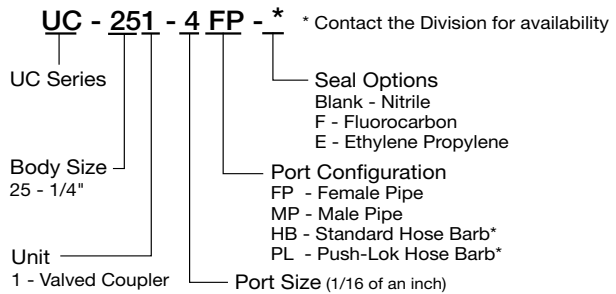

### Couplers - Female Pipe Thread



Body Size	Part No. Brass	Port End	Length	Largest Diameter	Wrench Flats	Weight (lbs.)
1/4	UC-251-4FP	1/4-18 NPSF	2.06	0.98	0.81	0.23
1/4	UC-251-6FP	3/8-18 NPSF	2.21	0.98	0.81	0.23

### Couplers - Male Pipe Thread



Body Size	Part No. Brass	Port End	Length	Largest Diameter	Wrench Flats	Weight (lbs.)
1/4	UC-251-4MP	1/4-18 NPTF	2.21	0.81	0.98	0.22
1/4	UC-251-6MP	3/8-18 NPTF	2.24	0.81	0.9	0.23



E-z-mate Series are exhaust type quick couplers that are designed to safely relieve air pressure prior to disconnection. When the locking sleeve is moved to shut off air flow, it automatically vents downstream allowing for disconnection at zero pressure and eliminating the risk of "hose whip".

### Features:

- Self-locking valve sleeve protects against accidental disconnection
- Push-to-connect operation
- Meets ISO 4414 requirements for a controlled pressure release system

### Applications include:

- Pneumatic tools
- Drop-down air lines

### Performance

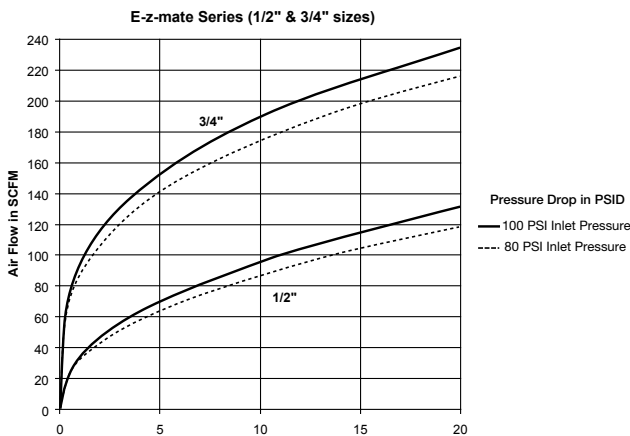
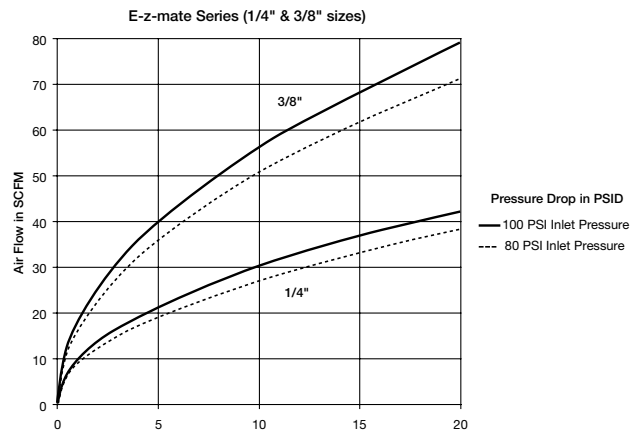

### Operation

Parker E-z-mate couplings combine push-to-connect, exhaust-style action with a self-locking valve sleeve to guard against accidental disconnection. Simply follow the direction of the On-Off arrow stamped on the valve sleeve. It's that easy.

To connect, push the nipple into the coupler. The black locking sleeve automatically slides forward securely locking the nipple in place. No air is allowed to flow through the coupling at this point. The valve sleeve is then rotated clockwise (when viewed from the coupler port end) to open flow and automatically engage the sleeve-lock mechanism.

To disconnect, rotate the valve sleeve counter clockwise (when viewed from the coupler end). The flow of air through the coupling will be shut off and all downstream air is vented to the atmosphere. The locking sleeve may now be retracted and the nipple removed. Lubricate sleeve as part of periodic maintenance to coupler.

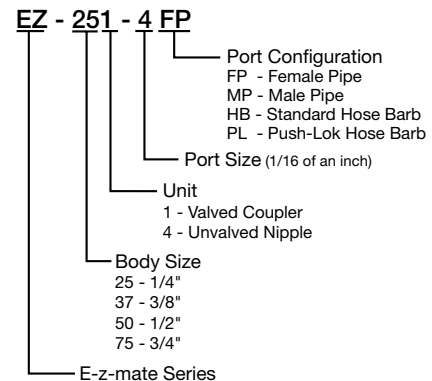

E-z mate Series Specifications				
Body Size	1/4	3/8	1/2	3/4
Rated Pressure (psi)	300			
Temperature Range (std seals)	-40° to +250° F			
Locking Device	4 balls	4 balls	6 balls	8 balls
Force required to connect (lbs.)	Less than 10			
Vacuum Service	Not Recommended			

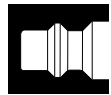

**Couplers - Female Pipe Thread**



Body Size	Part No. Steel	Port End	Length	Largest Diameter	Wrench Flats	Weight (lbs.)
1/4	EZ-251-4FP	1/4-18 NPTF	2.25	1.00	0.75	0.25
1/4	EZ-251-6FP	3/8-18 NPTF	2.68	1.01	0.88	0.29
3/8	EZ-371-6FP	3/8-18 NPTF	2.53	1.18	0.88	0.38
3/8	EZ-371-8FP	1/2-14 NPTF	3.00	1.30	1.12	0.50
1/2	EZ-501-8FP	1/2-14 NPTF	3.01	1.38	1.12	0.65
1/2	EZ-501-12FP	3/4-14 NPTF	3.44	1.59	1.38	0.70
3/4	EZ-751-12FP	3/4-14 NPTF	3.01	1.57	1.38	0.76
3/4	EZ-751-16FP	1-11 1/2 NPTF	3.52	1.80	1.56	0.92

**Couplers - Male Pipe Thread**



Body Size	Part No. Steel	Port End	Length	Largest Diameter	Wrench Flats	Weight (lbs.)
1/4	EZ-251-4MP	1/4-18 NPTF	2.85	1.00	0.75	0.30
1/4	EZ-251-6MP	3/8-18 NPTF	2.87	1.00	0.75	0.31
3/8	EZ-371-6MP	3/8-18 NPTF	3.10	1.18	0.88	0.44
1/2	EZ-501-8MP	1/2-14 NPTF	3.62	1.38	1.12	0.73
3/4	EZ-751-12MP	3/4-14 NPTF	4.04	1.57	1.38	0.90

**Couplers - Standard Hose Barb**



Body Size	Part No. Steel	Hose I.D.	Length	Largest Diameter	Wrench Flats	Weight (lbs.)
1/4	EZ-251-4HB	1/4	3.20	1.00	0.75	0.28
1/4	EZ-251-6HB	3/8	3.20	1.00	0.75	0.29
3/8	EZ-371-6HB	3/8	3.43	1.18	0.88	0.42
1/2	EZ-501-8HB	1/2	4.06	1.40	1.12	0.70

**Couplers - Push-Lok Hose Barb\***



Body Size	Part No. Steel	Hose I.D.	Length	Largest Diameter	Wrench Flats	Weight (lbs.)
1/4	EZ-251-4PL	1/4	3.03	1.00	0.75	0.28
1/4	EZ-251-6PL	3/8	3.18	1.00	0.75	0.29
3/8	EZ-371-6PL	3/8	3.38	1.18	0.88	0.42
1/2	EZ-501-8PL	1/2	3.91	1.38	1.12	0.70

\* Push-Lok hose barbs are designed for use with Parker Push-Lok hose and do not require clamps.



## Flow Control/ Check Valves

Series F flow control valves from Pioneer allow the end user to utilize the color-band reference on the valve stem as a great convenience and time-saver when resetting the valves. The Series N needle valves have the same Colorflow feature and are ideal as speed controls on hydraulic and pneumatic circuits where a reverse flow check is not needed. Finally, Pioneer offers Series C and Series DT check valves to allow free flow in one direction and shut-off in the reverse direction. The Series C has a soft-seal option and Series DT is very small and compact to fit into any application.

### Flow Control Valves

F Series.....	B-2
N Series.....	B-5

### Check Valves

C Series.....	B-8
DT Series.....	B-10

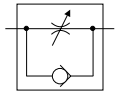

**General Description**

Series "F" flow control valves provide precise control of flow and shut-off in one direction, and automatically permit full flow in the opposite direction.

**Operation**

A two-step needle allows fine adjustment at low flow by using the first three turns of the adjusting knob; the next three turns open the valve to full flow, and also provide standard throttling adjustments.

**Features**

- The exclusive "Colorflow" color-band reference scale on the valve stem is a great convenience and time-saver in setting the valve originally and in returning it to any previous setting.
- A simple set screw locks the valve on any desired setting.
- A tamperproof option (T) feature is also available to prevent accidental or intentional adjustment of flow setting.



Specifications	
<b>Maximum Operating Pressure</b>	Brass: 140 Bar (2000 PSI); except for F1600 brass which is 35 Bar (500 psi) Steel & Stainless: 345 Bar (5000 psi) for 200 thru 820; 207 Bar (3000 psi) for all other sizes
<b>Return Check Poppet, Nominal Cracking Pressure</b>	0.4 Bar (5 PSI)
<b>Poppets</b>	Soft seal poppet in brass 200-1020 sizes Solid metal 416 stainless steel poppet on all other sizes and styles
<b>Operating Temperature</b>	-40°C to +121°C (-40°F to +250°F)

**Performance Curves**

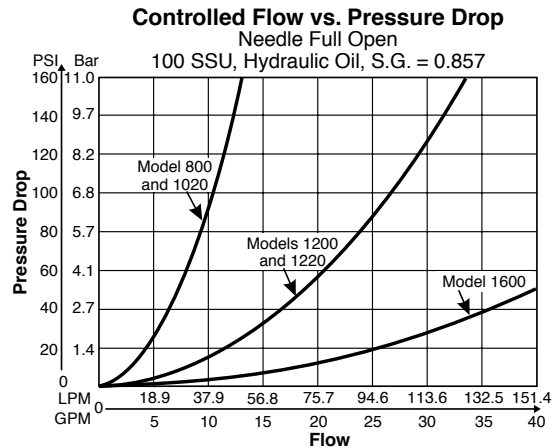
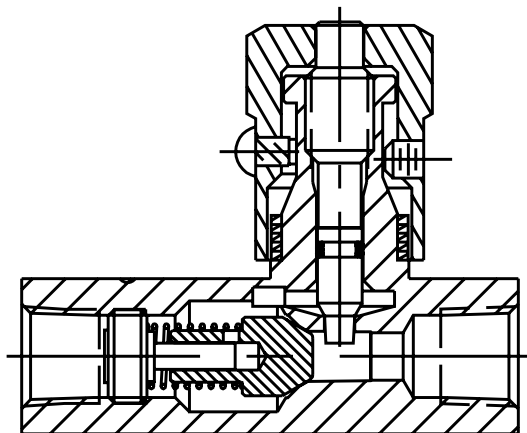
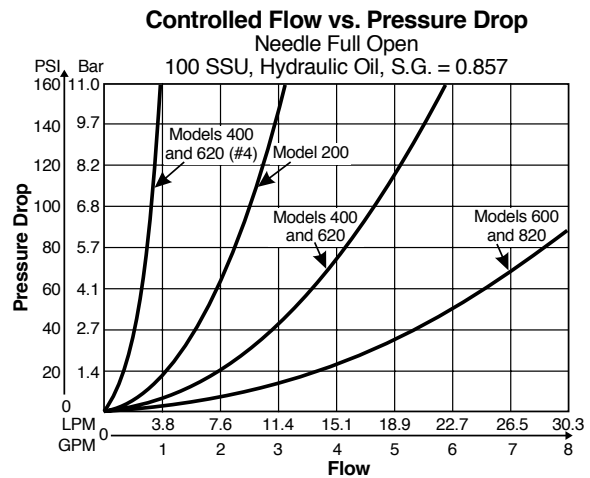

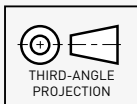
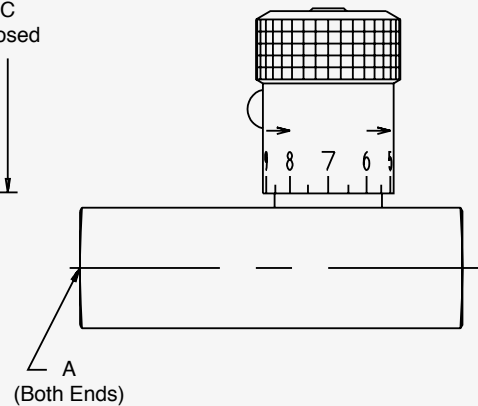
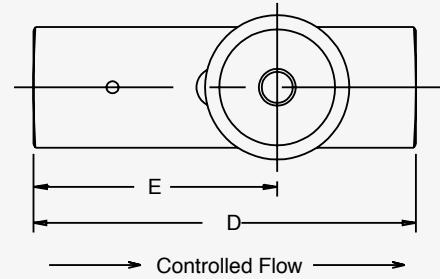
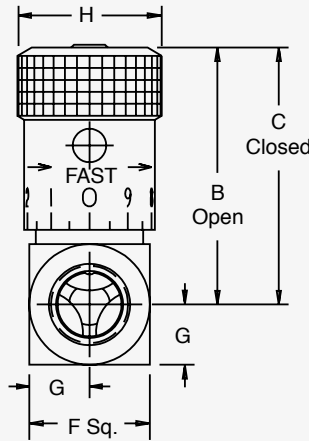
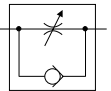

Ordering Information

Model Number	Max Flow LPM (gpm)	A	B	C	D	E	F	G	H
F400	19 (5)	1/4-18 NPTF	45.5 (1.79)	40.4 (1.59)	66.8 (2.63)	42.2 (1.66)	20.6 (0.81)	10.4 (0.41)	20.6 (0.81)
F600	30 (8)	3/8-18 NPTF	55.4 (2.18)	49.5 (1.95)	69.9 (2.75)	44.5 (1.75)	25.4 (1.00)	12.7 (0.50)	25.4 (1.00)
F800	57 (15)	1/2-14 NPTF	68.6 (2.70)	61.5 (2.42)	87.4 (3.44)	56.6 (2.23)	31.8 (1.25)	16.0 (0.63)	30.2 (1.19)
F1200	95 (25)	1/2-14 NPTF	85.9 (3.38)	71.4 (2.81)	98.6 (3.88)	65.5 (2.58)	38.1 (1.50)	19.1 (0.75)	35.1 (1.38)

\*Inch equivalents for millimeter dimensions are shown in (\*\*)



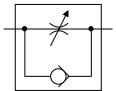

Ordering Information

Options

Code	Description
Omit	NPTF
8	BSPT
9	BSPP

Series

Size

Sizes available: Brass			
400	600	800	1200
Sizes available: Stainless Steel			
400	600	800	

Material

Code	Description
Omit	Standard Knob
B	Brass
S	Steel
*SS	Stainless Steel

Series F Brass Valves can be used for both air and oil service.

\* Available in 400, 600 and 800 sizes.

Needle Options

Code	Description
Omit	Standard Knob
4	Fine Metering (200, 400, 600, 620 sizes)

Other Options

Code	Description
Omit	Standard Knob
T*	Tamperproof
F	Finger Screw

\* Not available above 1200 size.

Seal Compound

Code	Description
Omit	Nitrile (Standard)
V	Fluorocarbon

Design Series

NOTE: Not required when ordering.

Flow Control / Check Valves

Model Number	Weight Kg (lbs.)
F400	0.2 (0.5)
F600	0.3 (0.7)
F800	0.7 (1.5)
F1200	1.2 (2.6)



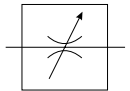

### General Description

Series "N" needle valves are ideal as speed controls on hydraulic and pneumatic systems where a reverse flow check is not needed. They provide excellent control and a reliable shutoff in a very small envelope.

### Operation

A two-step needle allows fine adjustment at low flow by using the first three turns of the adjusting knob; the next three turns open the valve to full flow, and also provide standard throttling adjustments.

### Features

- The exclusive "Colorflow" color-band reference scale on the valve stem is a great convenience and time-saver in setting the valve originally and in returning it to any previous setting.
- A simple set screw locks the valve on any desired setting.
- A tamperproof option (T) feature is also available to prevent accidental or intentional adjustment of flow setting.



Specifications	
Maximum Operating Pressure	Brass: 140 Bar (2000 PSI); except for N1600 brass which is 35 Bar (500 psi)
	Steel & Stainless: 345 Bar (5000 psi) for 200 thru 1220; 207 Bar (3000 psi) for all other sizes
	Steel: 345 Bar (5000 psi) for 200 thru 1220; 207 Bar (3000 psi) for all other sizes
Operating Temperature	-40°C to +121°C (-40°F to +250°F)

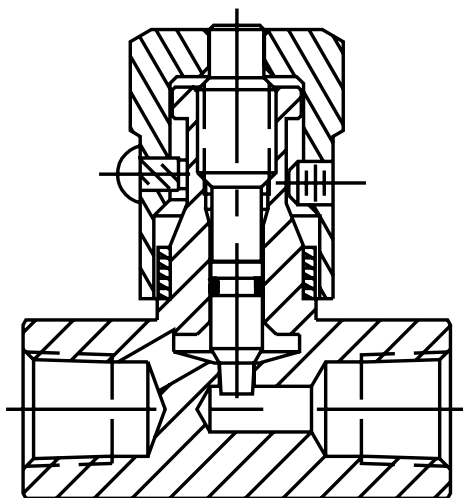

### Performance Curves

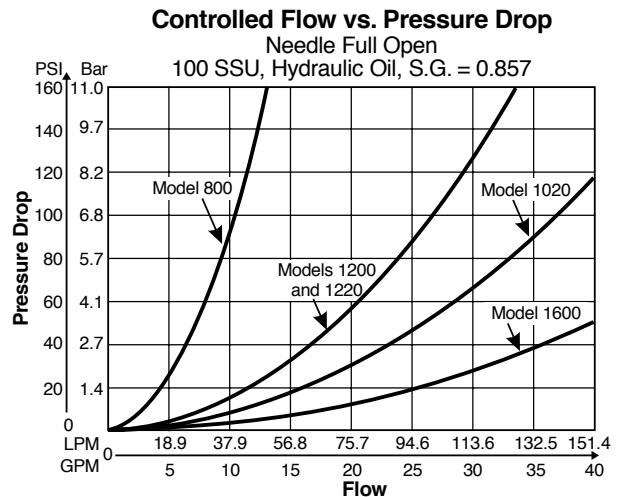
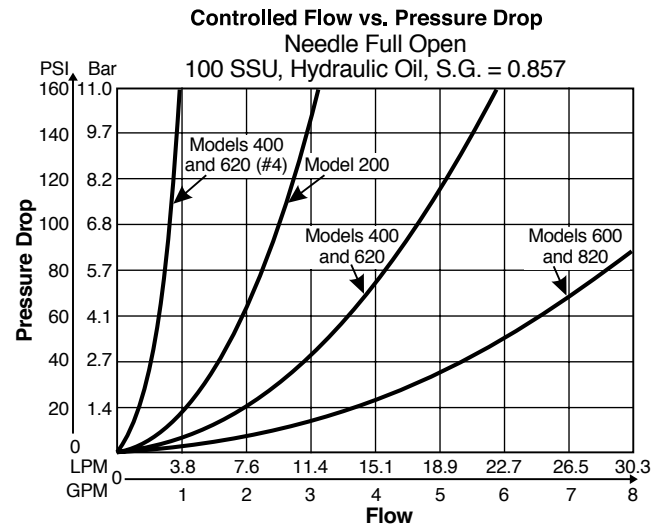

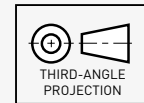
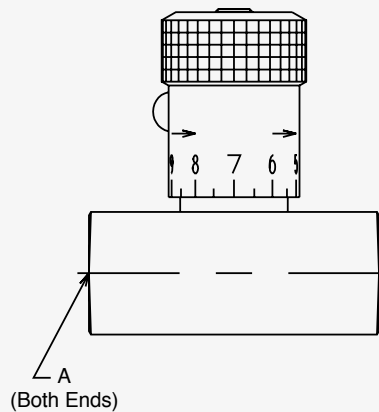
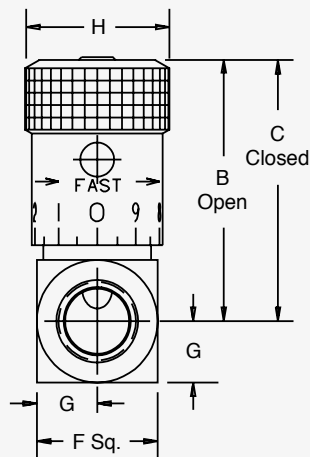
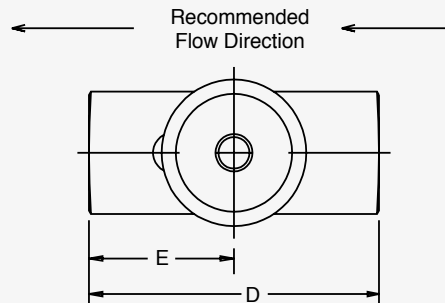
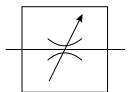

Flow Control / Check Valves

**Needle Valves - Series N**

Model Number	Max Flow LPM (gpm)	A	B	C	D	E	F	G	H
N400	19 (5)	1/4-18 NPTF	45.5 (1.79)	40.4 (1.59)	50.8 (2.00)	25.4 (1.00)	20.6 (0.81)	10.4 (0.41)	20.6 (0.81)
N600	30 (8)	3/8-18 NPTF	55.4 (2.18)	49.5 (1.95)	63.5 (2.50)	31.8 (1.25)	25.4 (1.00)	12.7 (0.50)	25.4 (1.00)
N800	57 (15)	1/2-14 NPTF	68.6 (2.70)	61.5 (2.42)	66.5 (2.62)	33.3 (1.31)	31.8 (1.25)	15.7 (0.62)	30.2 (1.19)
N1200	95 (25)	3/4-14 NPTF	85.9 (3.38)	71.4 (2.81)	82.6 (3.25)	41.1 (1.62)	38.1 (1.50)	19.1 (0.75)	35.1 (1.38)

\*Inch equivalents for millimeter dimensions are shown in (\*\*)



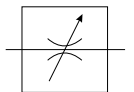

Ordering Information

Options

Code	Description
Omit	NPTF
8	BSPT
9	BSPP

Series

**N**

Size

Sizes available: Brass			
400	600	800	1200
Sizes available: Stainless Steel			
400	600	800	

Material

Code	Description
Omit	Standard Knob
B	Brass
S	Steel
*SS	Stainless Steel

Series F Brass Valves can be used for both air and oil service.  
\* Available in 400, 600 and 800 sizes.

Needle Options

Code	Description
Omit	Standard Knob
T*	Tamperproof
F	Finger Screw

\* Not available above 1200 size.

Other Options

Code	Description
Omit	Standard Knob
T*	Tamperproof
F	Finger Screw

Seal Compound

Code	Description
Omit	Nitrile (Standard)
V	Fluorocarbon

Design Series

NOTE: Not required when ordering.

Model Number	Weight Kg (lbs.)
N400	0.2 (0.5)
N600	0.3 (0.7)
N800	0.7 (1.5)
N1200	1.0 (2.3)

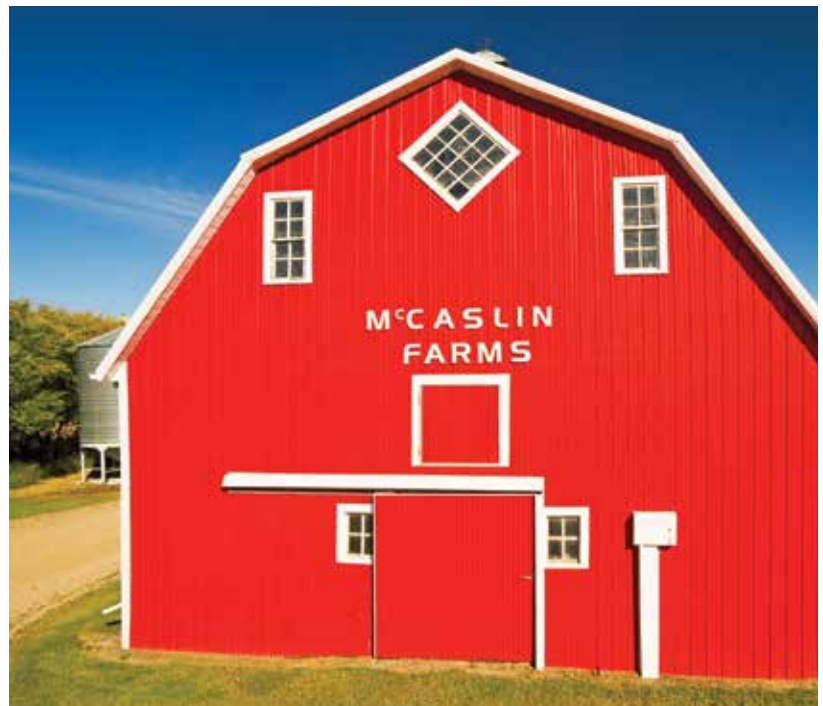

Flow Control / Check Valves



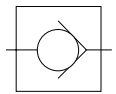

### General Description

Series "C" check valves permit free flow in one direction, and dependable shut-off in the reverse direction.

### Operation

When pressure going through the valve is increased to the cracking level the valve opens. When the pressure is reduced to below the cracking level the valve closes.

### Features

- Stainless steel poppets standard.
- Soft seal poppets are available.
- Triangular retainers guide the poppets, and hold the spring firmly in place even under high velocity and shock.



Flow Control / Check Valves

Specifications	
Maximum Operating Pressure	Brass: 140 Bar (2000 PSI); except for C1600 brass which is 35 Bar (500 psi)
	Steel & Stainless: 345 Bar (5000 psi) for 200 thru 820; 207 Bar (3000 psi) for all other sizes
Maximum Flow	C400: 19 LPM (5 GPM)
	C600: 30 LPM (8 GPM)
	C800: 57 LPM (15 GPM)
	C1200: 95 LPM (25 GPM)
Poppets	Soft seal poppet is standard for 200 through 800/1020 size.
	For cracking pressures > 15 PSI, solid metal poppets are standard

### Performance Curves

#### Controlled Flow vs. Pressure Drop

Free Flow 0.3 Bar (5 PSI) Cracking  
100 SSU, Hydraulic Oil

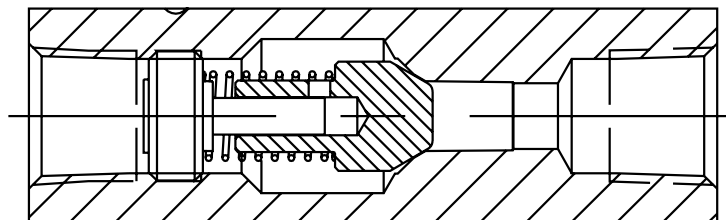
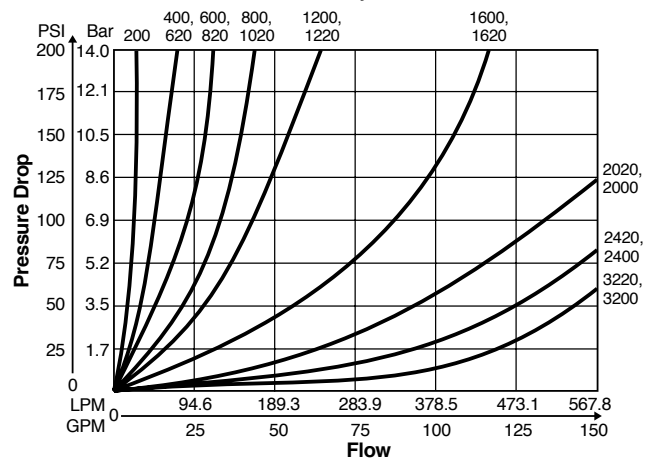

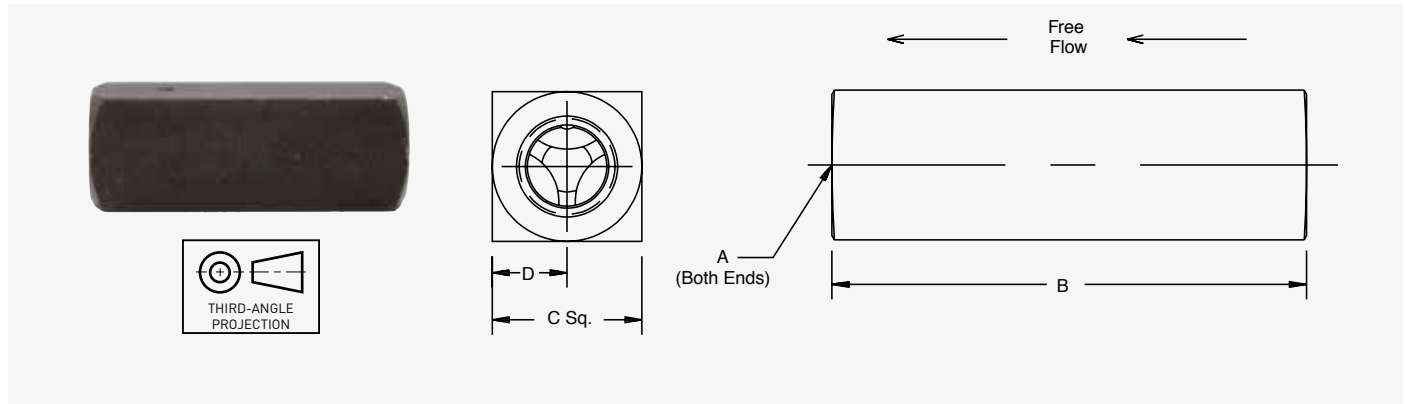
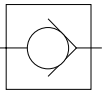

Needle Valves - Series C				
Model Number	A	B	C	D
C400	1/4-18 NPTF	66.8 [2.63]	20.6 [0.81]	10.4 [0.41]
C600	3/8-18 NPTF	69.9 [2.75]	25.4 [1.00]	12.7 [0.50]
C800	1/2-14 NPTF	87.4 [3.44]	31.8 [1.25]	16.0 [0.63]
C1200	3/4-14 NPTF	98.6 [3.88]	38.1 [1.50]	19.1 [0.75]

\*Inch equivalents for millimeter dimensions are shown in (\*\*)

Ordering Information

<input type="checkbox"/>	<input checked="" type="checkbox"/>	<input type="checkbox"/>	<input type="checkbox"/>	<input type="checkbox"/>	<input type="checkbox"/>	<input type="checkbox"/>	<input type="checkbox"/>																																									
Options	Series	Size	Material	Cracking Pressure	Seal Compound	Design Series	NOTE: Not required when ordering.																																									
<table border="1"> <thead> <tr> <th>Code</th> <th>Description</th> </tr> </thead> <tbody> <tr> <td>Omit</td> <td>NPTF</td> </tr> <tr> <td>8</td> <td>BSPT</td> </tr> <tr> <td>9</td> <td>BSPP</td> </tr> </tbody> </table>	Code	Description	Omit	NPTF	8	BSPT	9	BSPP	<table border="1"> <thead> <tr> <th colspan="2">Sizes available in Brass</th> </tr> </thead> <tbody> <tr> <td>400</td> <td>800</td> </tr> <tr> <td>600</td> <td>1200</td> </tr> <tr> <th colspan="2">Sizes available in Stainless Steel</th> </tr> <tr> <td>400</td> <td>800</td> </tr> <tr> <td>600</td> <td>-</td> </tr> </tbody> </table>	Sizes available in Brass		400	800	600	1200	Sizes available in Stainless Steel		400	800	600	-	<table border="1"> <thead> <tr> <th>Code</th> <th>Description</th> </tr> </thead> <tbody> <tr> <td>Omit</td> <td>Standard 0.4 Bar (5 PSI)</td> </tr> <tr> <td>65</td> <td>4.5 Bar (65 PSI)</td> </tr> </tbody> </table>	Code	Description	Omit	Standard 0.4 Bar (5 PSI)	65	4.5 Bar (65 PSI)	<table border="1"> <thead> <tr> <th>Code</th> <th>Description</th> </tr> </thead> <tbody> <tr> <td>Omit</td> <td>Nitrile [Standard]</td> </tr> <tr> <td>V</td> <td>Fluorocarbon</td> </tr> </tbody> </table>	Code	Description	Omit	Nitrile [Standard]	V	Fluorocarbon	<table border="1"> <thead> <tr> <th>Code</th> <th>Description</th> </tr> </thead> <tbody> <tr> <td>Omit</td> <td>Standard Knob</td> </tr> <tr> <td>B</td> <td>Brass</td> </tr> <tr> <td>S</td> <td>Steel</td> </tr> <tr> <td>*SS</td> <td>Stainless Steel</td> </tr> </tbody> </table>	Code	Description	Omit	Standard Knob	B	Brass	S	Steel	*SS	Stainless Steel	<p>Series C Brass Valves can be used for both air and oil service. * Available in 400, 600 and 800 sizes.</p>	
Code	Description																																															
Omit	NPTF																																															
8	BSPT																																															
9	BSPP																																															
Sizes available in Brass																																																
400	800																																															
600	1200																																															
Sizes available in Stainless Steel																																																
400	800																																															
600	-																																															
Code	Description																																															
Omit	Standard 0.4 Bar (5 PSI)																																															
65	4.5 Bar (65 PSI)																																															
Code	Description																																															
Omit	Nitrile [Standard]																																															
V	Fluorocarbon																																															
Code	Description																																															
Omit	Standard Knob																																															
B	Brass																																															
S	Steel																																															
*SS	Stainless Steel																																															

Model Number	Weight Kg (lbs.)	Model Number	Weight Kg (lbs.)	Model Number	Weight Kg (lbs.)	Model Number	Weight Kg (lbs.)
C400	0.2 [0.4]	C800	0.6 [1.3]	C1620	1.5 [3.3]	C2420	3.8 [8.4]
C600	0.2 [0.5]	C1020	0.6 [1.3]	C2000	2.8 [6.2]	C3200	7.0 [15.4]



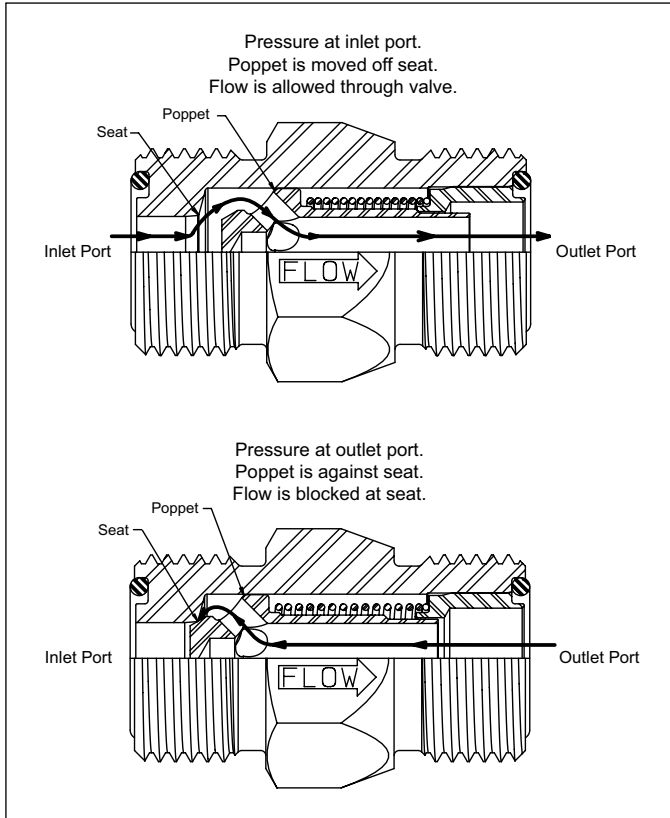
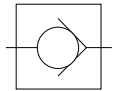

**Features**

Parker's Check Valves employ several unique features that insure years of trouble-free operation.

**Crack Pressure**

Crack pressure refers to the amount of fluid pressure in the free flow direction required to move the poppet off the seat. The normal crack pressure setting is 5 PSI; however, other crack pressures are available to allow the check valve to perform special circuit functions, or operate under unique conditions.

**Check valves are not field repairable or adjustable. Crack pressure settings are made at the factory only.**

Specifications				
Series	Body Size (in.)	Material	Rated Pressure (psi)	Crack Pressure Range (psi)
DT Series	1/4 - 1 1/4	Steel	5000	5-200

DT Series Pressure Table (psi)				
Body Size	Max Rated Pressure	MF (Male JIC 37)	MO (SAE O-Ring Boss)	MS (Male Seal-Lok)
1/4	5000	5000	5000	5000
3/8	5000	5000	5000	5000
1/2	5000	4500	5000	5000
5/8	5000	3500	5000	5000
3/4	5000	3500	5000	5000
1	5000	3000	5000	5000
1 1/4	4000	2500	4000	4000

**Applications**

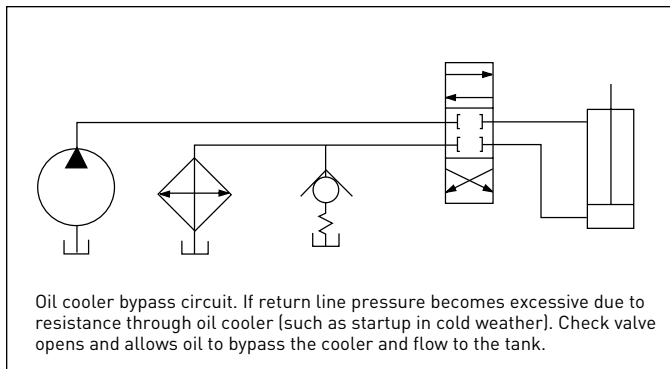
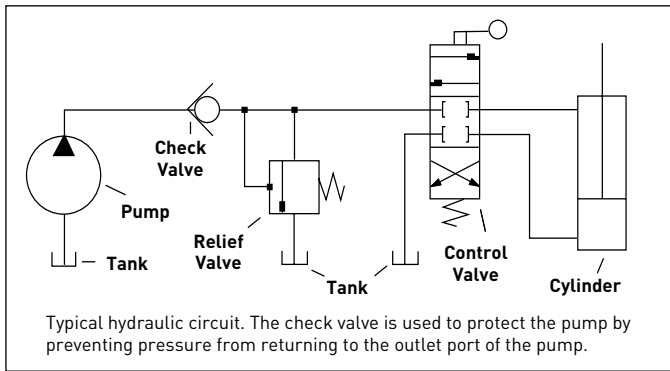

DT Series Installation Assembly Torque (ft-lbs)			
Body Size	MF (Male JIC 37)	MO (SAE O-Ring Boss)	MS (Male Seal-Lok)
1/4	Refer to Parker TFD Catalog 4300 for torque recommendation	13.3 +10% / -0%	Refer to Parker TFD Catalog 4300 for torque recommendation
3/8		22.1 +10% / -0%	
1/2		62.6 +10% / -0%	
5/8		84.8 +10% / -0%	
3/4		125.3 +10% / -0%	
1		199 +10% / -0%	
1 1/4		210 +10% / -0%	

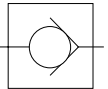

**Parker DT Series Check Valves Offer the Features of a Compact Body Size, and 5000 PSI Maximum Operating Pressure**

The DT Series check valves utilize the dependable, internal design features found in Parker check valves, but with the added benefit and convenience of compact design. Sizes are available from 1/4" to 1-1/4" with six different Fitting Styles.

The DT Series expands Parker's high quality product line of versatile and efficient check valves.



**Features**

1. Compact Design. Easy to plumb into tight circuits.
2. All steel construction. No internal gaskets or seals to wear out.
3. One-piece body eliminates threads and seals that may be potential leakage points.
4. Smooth flow stream. Poppet spring is isolated from flow stream.
5. Variety of end fittings.
6. Optional crack pressures available from 1 to 200 PSI.
7. Chromium-6 Free plated exterior finish.
8. Nitrile O-Ring included on MO and MS fittings.
9. Captive O-Ring Groove is standard on MS end fittings.

Flow Control / Check Valves

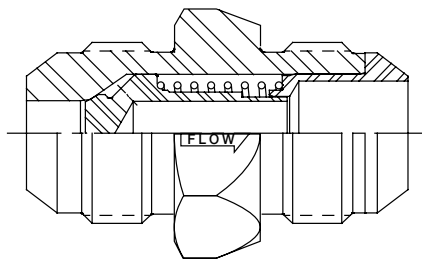

**DT-MFMF**

Male Flare 37° JIC Inlet to Male Flare 37° JIC Outlet

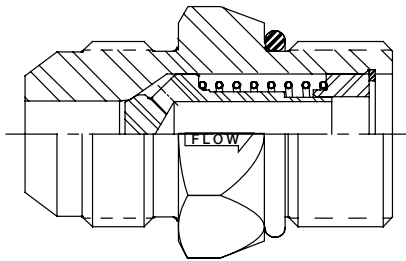

**DT-MFMO**

Male Flare 37° JIC Inlet to Male O-Ring Boss Outlet

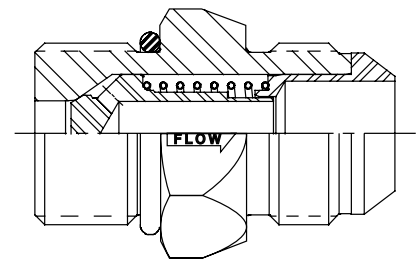

**DT-MOMF**

Male O-Ring Boss Inlet to Male Flare 37° JIC Outlet

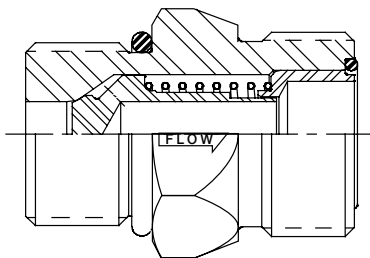

**DT-MOMS**

Male O-Ring Boss Inlet to Male Seal-Lok® Outlet

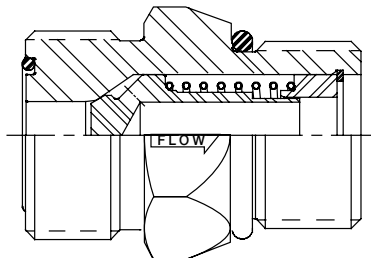

**DT-MSMO**

Male Seal-Lok® Inlet to Male O-Ring Boss Outlet

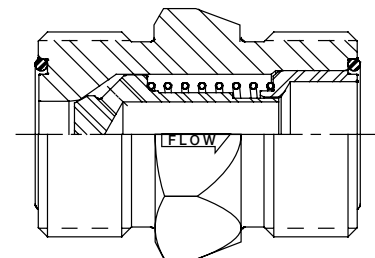

**DT-MSMS**

Male Seal-Lok® Inlet to Male Seal-Lok® Outlet



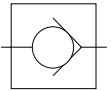

**DT-MFMF** Male Flare 37° JIC Inlet to Male Flare 37° JIC Outlet



Body Size	Part Number	Inlet Port End	Outlet Port End	Inlet Port Length	Hex	Outlet Port Length	Wrench Flats	Standard Crack Pressure (psi)
3/8	DT-370-MFMF-**	9/16-18 UNF	9/16-18 UNF	0.56	0.44	0.56	0.75	1, 5, 65
1/2	DT-500-MFMF-**	3/4-16 UNF	3/4-16 UNF	0.66	0.50	0.66	0.88	5, 65
5/8	DT-620-MFMF-**	7/8-14 UNF	7/8-14 UNF	0.76	0.50	0.76	1.06	5
3/4	DT-750-MFMF-**	1-1/16- 12 UN	1-1/16- 12 UN	0.86	0.50	0.86	1.25	1, 5, 65
1	DT-1000-MFMF-**	1-5/16- 12 UN	1-5/16- 12 UN	0.91	0.62	0.91	1.50	5, 65
1 1/4	DT-1250-MFMF-**	1-5/8 - 12 UN	1-5/8 - 12 UN	0.96	1.06	0.96	1.88	1, 5 psi

**DT-MFMO** Male Flare 37° JIC Inlet to Male O-Ring Boss Outlet



Body Size	Part Number	Inlet Port End	Outlet Port End	Inlet Port Length	Hex	Outlet Port Length	Wrench Flats	Standard Crack Pressure (psi)
1/4	DT-250-MFMO-**	7/16-20 UNF	0.55	0.44	0.43	7/16-20 UNF	0.62	5
3/8	DT-370-MFMO-**	9/16-18 UNF	0.56	0.44	0.47	9/16-18 UNF	0.75	1, 5, 65
1/2	DT-500-MFMO-**	3/4-16 UNF	0.66	0.50	0.55	3/4-16 UNF	0.88	5, 65
5/8	DT-620-MFMO-**	7/8-14 UNF	0.76	0.50	0.63	7/8-14 UNF	1.06	5
3/4	DT-750-MFMO-**	1-1/16 - 12 UN	0.86	0.50	0.73	1-1/16 - 12 UN	1.25	1, 5, 65
1	DT-1000-MFMO-**	1-5/16 - 12 UN	0.91	0.62	0.73	1-5/16 - 12 UN	1.50	5, 65
1 1/4	DT-1250-MFMO-**	1-5/8 - 12 UN	0.96	1.06	0.73	1-5/8 - 12 UN	1.88	1, 5

**DT-MOMF** Male O-Ring Boss Inlet to Male Flare 37° JIC Outlet



Body Size	Part Number	Inlet Port End	Outlet Port End	Inlet Port Length	Hex	Outlet Port Length	Wrench Flats	Standard Crack Pressure (psi)
1/4	DT-250-MOMF-**	7/16-20 UNF	0.43	0.44	0.55	7/16-20 UNF	0.62	5
3/8	DT-370-MOMF-**	9/16-18 UNF	0.47	0.44	0.56	9/16-18 UNF	0.75	1, 5, 65
1/2	DT-500-MOMF-**	3/4-16 UNF	0.55	0.5	0.66	3/4-16 UNF	0.88	5, 65
5/8	DT-620-MOMF-**	7/8-14 UNF	0.63	0.5	0.76	7/8-14 UNF	1.06	5
3/4	DT-750-MOMF-**	1-1/16 - 12 UN	0.73	0.5	0.86	1-1/16 - 12 UN	1.25	1, 5, 65
1	DT-1000-MOMF-**	1-5/16 - 12 UN	0.73	0.62	0.91	1-5/16 - 12 UN	1.5	5, 65
1 1/4	DT-1250-MOMF-**	1-5/8 - 12 UN	0.73	1.06	0.96	1-5/8 - 12 UN	1.88	1, 5

Flow Control / Check Valves

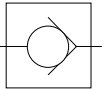

**DT-MOMS** Male O-Ring Boss Inlet to Male Seal-Lok® Outlet



Body Size	Part Number	Inlet Port End	Outlet Port End	Inlet Port Length	Hex	Outlet Port Length	Wrench Flats	Standard Crack Pressure (psi)
1/4	DT-250-MOMS-**	7/16-20 UNF	0.43	0.45	0.39	9/16-18 UNF	0.62	5
3/8	DT-370-MOMS-**	9/16-18 UNF	0.47	0.44	0.44	11/16-16 UN	0.75	1, 5, 65
1/2	DT-500-MOMS-**	3/4-16 UNF	0.55	0.5	0.51	13/16-16 UN	0.88	5, 65
5/8	DT-620-MOMS-**	7/8-14 UNF	0.63	0.5	0.62	1-14 UNS	1.06	5
3/4	DT-750-MOMS-**	1-1/16 - 12 UN	0.73	0.5	0.68	1-3/16 - 12 UN	1.25	1, 5, 65
1	DT-1000-MOMS-**	1-5/16 - 12 UN	0.73	0.62	0.7	1-7/16 - 12 UN	1.5	5, 65
1 1/4	DT-1250-MOMS-**	1-5/8 - 12 UN	0.73	1.06	0.7	1-11/16 - 12 UN	1.88	1, 5

**DT-MSMO** Male Seal-Lok® Inlet to Male O-Ring Boss Outlet



Body Size	Part Number	Inlet Port End	Outlet Port End	Inlet Port Length	Hex	Outlet Port Length	Wrench Flats	Standard Crack Pressure (psi)
3/8	DT-370-MSMO-**	11/16-16 UN	0.44	0.44	0.47	9/16-18 UNF	0.75	1, 5, 65
1/2	DT-500-MSMO-**	13/16-16 UN	0.51	0.5	0.55	3/4-16 UNF	0.88	5, 65
5/8	DT-620-MSMO-**	1-14 UNS	0.62	0.49	0.63	7/8-14 UNF	1.06	5
3/4	DT-750-MSMO-**	1-3/16 - 12 UN	0.68	0.5	0.73	1-1/16 - 12 UN	1.25	1, 5, 65
1	DT-1000-MSMO-**	1-7/16 - 12 UN	0.7	0.62	0.73	1-5/16 - 12 UN	1.5	5, 65
1 1/4	DT-1250-MSMO-**	1-11/16 - 12 UN	0.7	1.06	0.73	1-5/8 - 12 UN	1.88	1,

**DT-MSMS** Male Seal-Lok® Inlet to Male Seal-Lok® Outlet



Body Size	Part Number	Inlet Port End	Outlet Port End	Inlet Port Length	Hex	Outlet Port Length	Wrench Flats	Standard Crack Pressure (psi)
3/8	DT-370-MSMS-**	11/16-16 UN	0.44	0.44	0.44	11/16-16 UN	0.75	1, 5, 65
1/2	DT-500-MSMS-**	13/16-16 UN	0.51	0.5	0.51	13/16-16 UN	0.88	5, 65
5/8	DT-620-MSMS-**	1-14 UNS	0.62	0.5	0.62	1-14 UNS	1.06	5
3/4	DT-750-MSMS-**	1-3/16 - 12 UN	0.68	0.5	0.68	1-3/16 - 12 UN	1.25	1, 5, 65
1	DT-1000-MSMS-**	1-7/16 - 12 UN	0.7	0.62	0.7	1-7/16 - 12 UN	1.5	5, 65
1 1/4	DT-1250-MSMS-**	1-11/16 - 12 UN	0.7	1.06	0.7	1-11/16 - 12 UN	1.88	1, 5



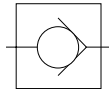

Flow Data

DT Series (1/4" & 3/8")  
Test Fluid: Oil - 200 SUS

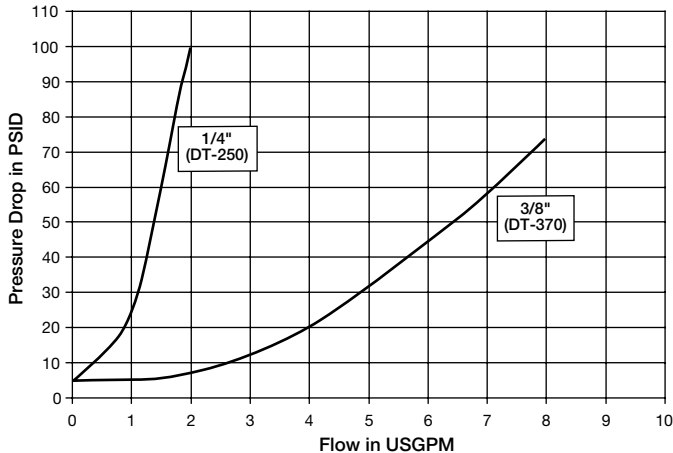

DT Series (1/2", 5/8" & 3/4")  
Test Fluid: Oil - 200 SUS

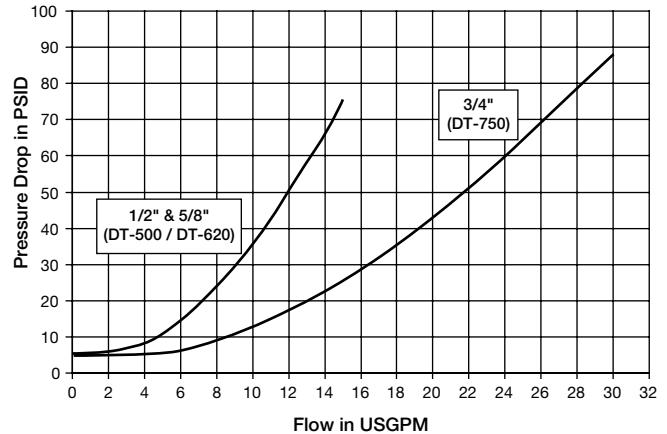

DT Series (1" & 1-1/4")  
Test Fluid: Oil - 200 SUS

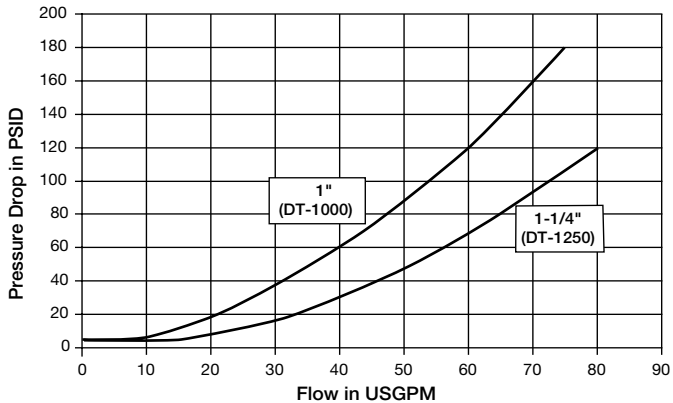

Flow Control / Check Valves

Ordering Information

**DT - XXX - XXXX - XX**

Series

Crack Pressure

1 = 1 psi

5 = 5 psi

65 = 65 psi

Other Crack Pressures up to 200 PSI in 5 PSI increments are available. Contact the Division for price and delivery on non-standard crack pressures.

Size	Flow (USGPM)
1/4	250
3/8	370
1/2	500
5/8	620
3/4	750
1	1000
1 1/4	1250

Fitting Style	Description
MFMF	Male Flare Inlet to Male Flare Outlet
MFMO	Male Flare Inlet to Male O-Ring Boss Outlet
MOMF	Male O-Ring Boss Inlet to Male Flare Outlet
MOMS	Male O-Ring Boss Inlet to Male Face Seal Outlet
MSMO	Male Face Seal Inlet to Male O-Ring Boss Outlet
MSMS	Male Face Seal Inlet to Male Face Seal Outlet



## Diagnostic Equipment

To meet the needs of today's complex hydraulic systems, Pioneer offers a variety of diagnostic equipment, from digital pressure gauges to state of the art meters with multiple inputs. Customized kit options and accessories provide versatility for your individual requirements.

### Digital Pressure Gauges

Service Junior ..... C-2

### Diagnostic Meters and Kits

Serviceman Plus ..... C-3

Parker Service Master Easy ..... C-7

### Accessories

Components & Accessories .....C-10

Temperature Sensor .....C-12

Voltage Adapter .....C-12

Tachometer.....C-12

Cables .....C-12

Software.....C-12

Frequency Converter.....C-12

Transducers.....C-13

Flow Sensors .....C-15

### Test Port Quick Couplings

PD Series .....C-17

Fluid Sampling Kit .....C-20

## The Parker ServiceJunior is an Integrated Digital Pressure Gauge with Minimum/Maximum Memory Capability

- Hand held digital pressure gauge
- Measure and display pressure
- Easy operation
- Backlit display
- User-adjustable pressure units
- Min/Max memory
- Battery life indicator applications
- Ranges for hydraulics and pneumatics
- Scanning rate of 10ms
- Fluid temperature: -4° to 176°F
- Colored covers correspond with pressure ranges for easy identification



### Cover Color Code

Blue	-14.5 to 230 PSI (-1 to 16 bar)
Green	0 to 1500 PSI (0 to 100 bar)
Orange	0 to 5800 PSI (0 to 400 bar)
Red	0 to 8700 PSI (0 to 600 bar)

### Part Numbers and Specifications

ServiceJunior with PD Coupler	ServiceJunior with EMA3 Coupler	ServiceJunior with 1/4" NPT Port	Measuring Range	Overload Pressure (psi)	Resolution (psi)	Accuracy
SCJR-0250-PD	SCJR-0250-EMA	SCJR-0250-4MP	-14.5 to 230 PSI (-1 to 16 bar)	580	0.1	0.5% FS
SCJR-1500-PD	SCJR-1500-EMA	SCJR-1500-4MP	0 to 1500 PSI (0 to 100 bar)	2,900	1	
SCJR-5800-PD	SCJR-5800-EMA	SCJR-5800-4MP	0 to 5800 PSI (0 to 400 bar)	11,600	1	
SCJR-8700-PD*	SCJR-8700-EMA**	SCJR-8700-4MP	0 to 8700 PSI (0 to 600 bar)	14,500	1	

\* PD Couplers rated to 6,000 PSI max

\*\* EMA3 Couplers rated to 9,000 PSI max

### Accessories

Part Number	Description
PD240	PD Series Diagnostic Coupler
SCA-7/16-EMA-3	7/16 - 20UNF-2B female to M16X2.0 EMA3 female swivel
SCJA-1/4	7/16 - 20UNF-2B female to 1/4" NPT male adapter
PDH-19	19" PD Hose extension to be used with PD nipple
PDH-32	32" PD Hose extension to be used with PD nipple
SMA3-400	16" (400 mm) Hose assembly for EMA M16X2.0 interface
SCC-110	Storage case for one gauge and diagnostic adapters
SCC-300	Storage case for three gauges and diagnostic adapters

## Hand-Held Diagnostic Meter to Measure Pressure, Temperature, Flow and Rotational Speed for Hydraulic and Pneumatic Systems

- Easy operation
- Rugged design
- Compact Dimensions
- Two line display
- Auto sensor recognition
- MIN/MAX Memory
- Pressure differential
- External power supply
- Data output for PC

The Serviceman Plus is an extremely robust, portable and easy-to-use measuring device. With a scan rate of 1 ms and the ability to read pressure, flow, temperature and RPM, it is versatile for use with mobile and industrial systems.

Data can be conveniently saved to a removable nano USB stick or transferred through USB interface to a PC for further analysis with SensoWin software.

The Serviceman Plus is available in two designs. One with two inputs for analog sensors and the other with CAN interface for up to three CAN sensors.



Diagnostic Equipment

Serviceman Plus Technical Data	
<b>Interfaces</b> <ul style="list-style-type: none"> <li>• USB device: Online data transfer between device and PC via SensoWin Software; measured value transfer: ACT/MIN/MAX, min. 5 mns; USB standard: 2.0, full speed; connection assembly: Micro USB socket, protected, type B</li> <li>• USB host: Connection of USB memory stick, max. 4 GB; recommended types: Delock USB 2.0 nano memory stick, Intenso Micro Line; USB standard: 2.0, full speed, max. 100 mA; connection assembly: Micro USB socket, protected, type B</li> </ul>	<b>Battery</b> <p><b>Analog Version:</b></p> <ul style="list-style-type: none"> <li>• Type: Lithium-ion pack: 3.7 V DC/2250 mAh</li> <li>• Battery charging time with power supply: Approx. 3.5 hours</li> <li>• Battery discharge period: &gt; 8 hours, with 2 sensors</li> </ul> <p><b>CAN Version:</b></p> <ul style="list-style-type: none"> <li>• Type: Lithium-ion pack: 3.7 V DC/4550 mAh</li> <li>• Battery charging time with power supply: Approx. 7 hours</li> <li>• Battery discharge period: &gt; 8 hours, with 2 CAN-BUS sensors</li> </ul>
<b>Memory</b> <ul style="list-style-type: none"> <li>• Internal measure value memory: 1 measurement, approx. 15,000 data records (270,000 measure values ACT/MIN/MAX)</li> <li>• USB memory stick: 1 GB supplied</li> </ul>	<b>Casing</b> <ul style="list-style-type: none"> <li>• Material of casing: PC/ABS</li> <li>• Material of casing protective cover: TPU</li> <li>• Dimensions (W x H x D): 96 x 172 x 54 mm</li> <li>• Weight: approx. 540g</li> </ul>
<b>Functions</b> <ul style="list-style-type: none"> <li>• Difference; addition; output; ACT; MIN; MAX; FS; TEMP display; battery charge; start-stop measurement</li> </ul>	<b>Operating Environment</b> <ul style="list-style-type: none"> <li>• Operating temperature: 0-50°C</li> <li>• Storage temperature: -25-60°C</li> <li>• Relative humidity: &lt;80%</li> <li>• Environmental assessment: DIN EN 60068-2-32 (1 m free fall)</li> <li>• Protection category (EN60529): Analog IP54, CAN IP67</li> </ul>
<b>Display</b> <ul style="list-style-type: none"> <li>• Type: FSTN-LCD, graphical with LED background lighting</li> <li>• Visible area: 62 mm x 62 mm</li> <li>• Resolution: 130 x 130 pixels</li> </ul>	<b>PC Software</b> <ul style="list-style-type: none"> <li>• Read measurement data, show, analyse on PC; read device settings, edit; load device setting from library to manual measuring device</li> </ul>
<b>Voltage (external)</b> <ul style="list-style-type: none"> <li>• Micro-USB socket, type B, + 5 V DC max 1000MA</li> </ul>	

SCM-155-2-05 CAN Version

**CAN Inputs:**

- CAN-Bus sensor auto recognition
- Plug connection: 5-pol, M12 x 1, SPEEDCON plug
- Sampling rate P-channel: 1 ms

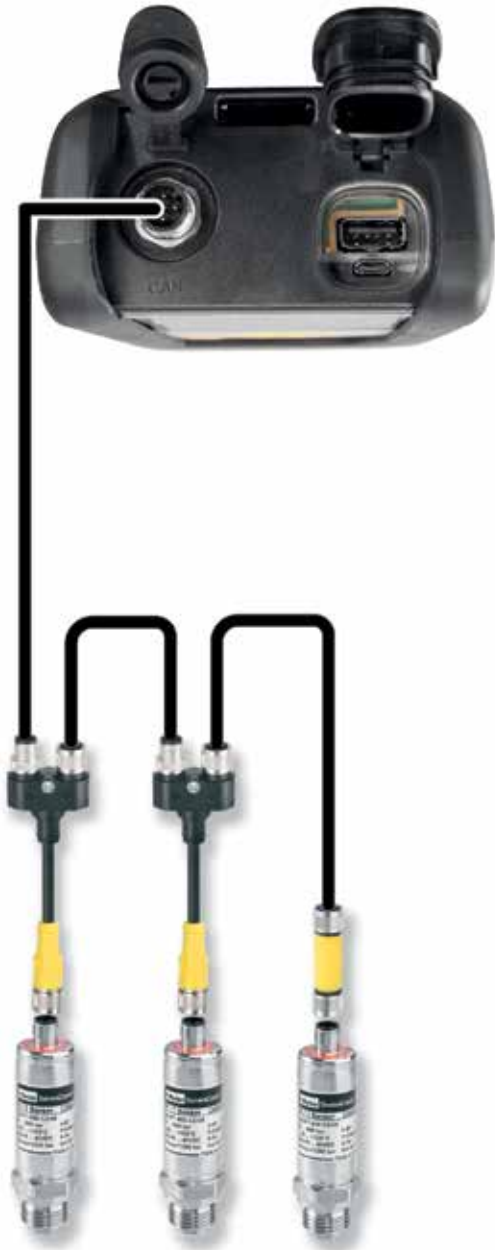

SCM-155-0-02 Analog Version

**Analog Inputs:**

- Analog sensor auto recognition
- Measurement Precision: +/- 0.02 +/- one digit
- Plug Connection: 5-pol, push-pull
- Sampling rate P-channel: 1 ms



Diagnostic Equipment



PDS4 (CAN version) Kit Contents:	Part Number
Serviceman Plus (CAN)	SCM-155-2-05
CD with SensoWin, documentation and instructions	CD 4078
Case	SCC-210
CAN Transducers (1 or 2)	PD XXXXX-XXXX-CAN
CAN Transducer Connection Cable (1 or 2 based on transducer #)	SCK-401-05-4F-4M
Power Supply	SCSN-440
CAN Y cable (only included with 2 transducer kit)	SCK-401-0.3-Y
Terminator Resistor	SCK-401-R
Nano USB Stick - 1 GB	SCK-USB-MINISTICK
USB Connection Cable - 1 meter	SCK-315-02-36

PDS4 (Analog version) Kit Contents:	Part Number
Serviceman Plus (Analog)	SCM-155-0-02
CD with SensoWin, documentation and instructions	CD 4078
Case	SCC-210
Analog Transducers (1 or 2)	PD XXXXX-XXXX
Analog Transducer Connection Cable (1 or 2 based on transducer #)	SCK-102-03-02
Power Supply	SCSN-440
Nano USB Stick - 1 GB	SCK-USB-MINISTICK
USB Connection Cable - 1 meter	SCK-315-02-36

**Code for Ordering Kits:**

PDS4 - X - XX - XX - XXX

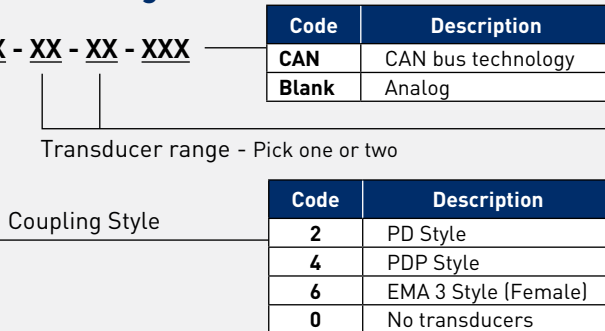

Code	Description
<b>CAN</b>	CAN bus technology
<b>Blank</b>	Analog

Code	Pressure (psi)	Color
<b>01</b>	-14.5 – 220	Blue
<b>06</b>	0 – 870	Green
<b>15</b>	0 – 2175	Yellow
<b>40</b>	0 – 5800	Orange
<b>60</b>	0 – 8700	Red
<b>00</b>	No transducers	

Code	Description
<b>2</b>	PD Style
<b>4</b>	PDP Style
<b>6</b>	EMA 3 Style (Female)
<b>0</b>	No transducers

**Additional Transducers** - Code for Ordering Separately:

PD XXXXX - XXXX - XXX

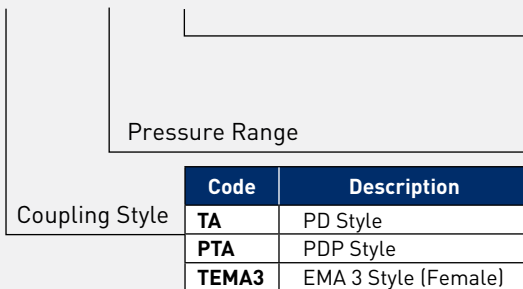

Code	Description
<b>CAN</b>	CAN bus technology
<b>Blank</b>	Analog

Code	Pressure (psi)	Color
<b>0100</b>	-14.5 – 220	Blue
<b>0600</b>	0 – 870	Green
<b>1500</b>	0 – 2175	Yellow
<b>4000</b>	0 – 5800	Orange
<b>6000</b>	0 – 8700	Red

Code	Description
<b>TA</b>	PD Style
<b>PTA</b>	PDP Style
<b>TEMA3</b>	EMA 3 Style (Female)

**Flow Sensors** - Code for Ordering Separately:

SCFT- XXXX - XXX - XXX

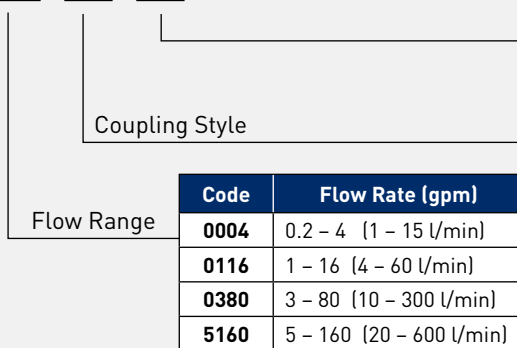

Code	Description
<b>CAN</b>	CAN bus technology
<b>Blank</b>	Analog

Code	Description
<b>PD</b>	PD Style
<b>PDP</b>	PDP Style
<b>EMA</b>	EMA 3 Style

Code	Flow Rate (gpm)
<b>0004</b>	0.2 – 4 (1 – 15 l/min)
<b>0116</b>	1 – 16 (4 – 60 l/min)
<b>0380</b>	3 – 80 (10 – 300 l/min)
<b>5160</b>	5 – 160 (20 – 600 l/min)

Diagnostic Equipment

**The Parker Service Master Easy Gives You the Ability to Measure and Store Operational Parameter Data Simultaneously or Switch Between Them with Ease**

- Rugged hand held diagnostic meter
- Measure and display pressure, flow, rotational speed and temperature
- Four sensor inputs
- Intuitive operation
- Auto sensor recognition
- Four line numerical display
- Calculated channels
- Store data on device
- SensoWin software utility
- Scan rate of 1ms



**Service Master Easy SCM-340-2-02 Technical Data**

Functions	Ambient Conditions	Meter
Differential Value Measurement	Operating Temperatures	Digital LCD Text Display
MIN/MAX Memory	32°F to 122°F (0°C to 50°C)	- 128x64 pixels
On line data transfer	Storage Temperatures	- 72x40 mm screen
Battery level indicator	-4°F to 140°F (-20°C to 60°C)	Character Height 6 mm
Power calculation (display only)	Protection class IP54	Display of Pressure, Temperature, Flow and Rotational Speed
Flow run-out (display only)	<b>Housing</b>	
Auto power off	Glass reinforced polyamide	- Pressure in PSI and Bar
<b>Output</b>	12-Key tactile touch membrane	- Temperature in °F and °C
USB 2.0 interface	EMC Protection	- Flow in GPM and l/min.
<b>Power Requirements</b>	- Electromagnetic interference	- Rotational Speed in RPM
Internal rechargeable Ni-MH battery	(DIN/EN 50081, Part 1)	<b>Inputs</b>
Recharge circuit for use with external power supply.	- Immunity to emitted interference	Four 5-pin push-pull style connectors
Operating time - 8 hours	(DIN/EN 50082, Part 2)	Automatic Sensor Recognition for pressure, temperature or rotational speed sensors
Charge time - 3 hours	<b>Dimensions</b>	
Excitation voltage (12-30 VDC)	Length/Height/Width	12 Bit A/D Converter (4096 steps)
<b>Memory Functions</b>	- 9.25 x 4.19 x 2.09	Selectable scanning rate in 1 ms intervals
Memory capacity	- (235 x 106 x 52 mm)	Burst Mode 0.25 ms (input 1 only)
- 1,000,000 data points max	<b>Weight</b>	
- 250,000 points per curve max	1.2 lbs (700 grams)	
Variable measuring period up to 100 hours		
Manual and automatic triggering		

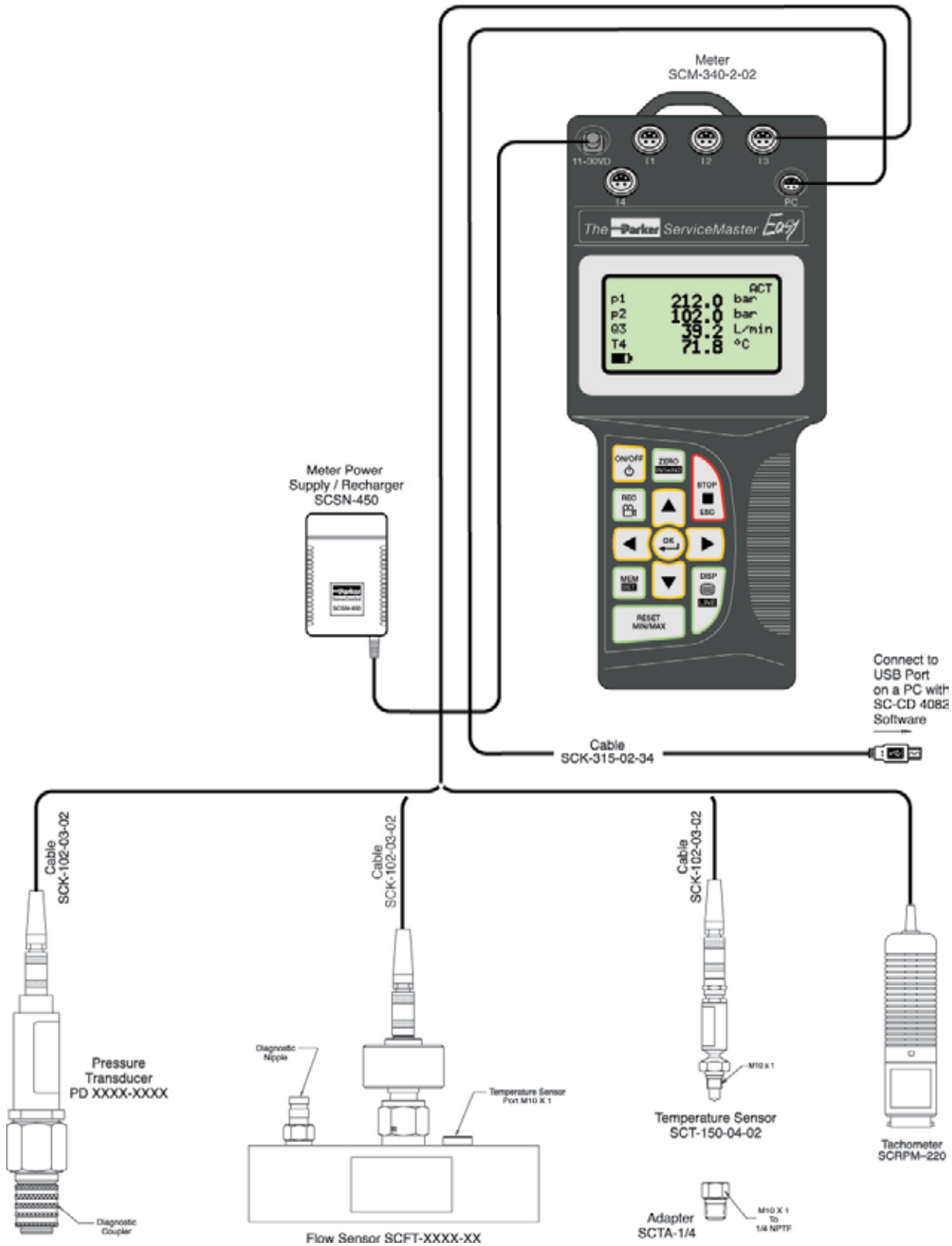



Kit Contents:	
Case	SC-690
The Parker Service Master Easy Meter	SCM-340-2-02
2 Transducers (see ordering Information below)	(See Below)
2 Transducer Cables (3m)	SCK-102-03-02
Power Supply	SCSN-450
SensoWin Software 6.0	SC-CD 4082
USB Computer Cable	SCK-315-02-34
Operating Manual (incl. with the Parker Service Master Easy Meter)	

**Code for Ordering Service Master Easy Kits:**

PDSME XX-X-XX-XX

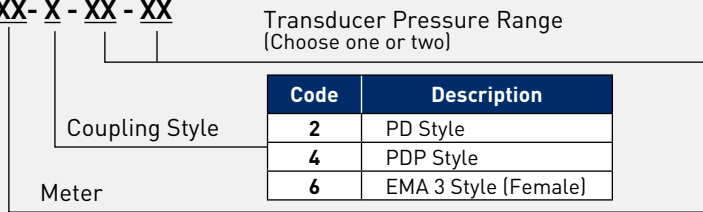

Transducer Pressure Range  
(Choose one or two)

Code	Description
2	PD Style
4	PDP Style
6	EMA 3 Style (Female)

Code	Pressure (psi)	Color
01	-14.5 - +220	Blue
06	0 - 870	Green
15	0 - 2175	Yellow
40	0 - 5800	Orange
60	0 - 8700	Red

Code	Description
34	The Parker Service Master Easy 340 Meter

**Additional Transducers** - Code for Ordering Separately:

PD XXXXX - XXXX

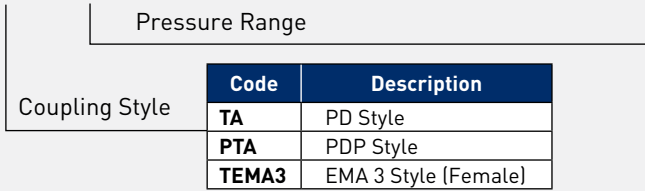

Code	Description
TA	PD Style
PTA	PDP Style
TEMA3	EMA 3 Style (Female)

Code	Pressure (psi)	Color
0100	-14.5 - +220	Blue
0600	0 - 870	Green
1500	0 - 2175	Yellow
4000	0 - 5800	Orange
6000	0 - 8700	Red

**Flow Sensors** - Code for Ordering Separately:

SCFT- XXXX - XXX

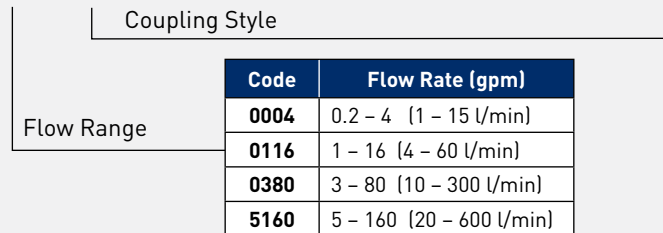

Code	Flow Rate (gpm)
0004	0.2 - 4 (1 - 15 l/min)
0116	1 - 16 (4 - 60 l/min)
0380	3 - 80 (10 - 300 l/min)
5160	5 - 160 (20 - 600 l/min)

Code	Description
PD	PD Style
PDP	PDP Style
EMA	EMA 3 Style (Female)



Diagnostic Meters and Accessories

Description	The Parker Serviceman Plus	The Parker Service Master Easy	Part Number
<b>The Parker Serviceman Plus</b> Hand-held meter, 2-3 inputs (Includes SCSN-440 Power Supply)	■		SCM-155-2-05 (CAN) SCM-155-0-02 (Analog)
<b>The Parker Service Master Easy</b> Hand-held meter, 4 inputs, up to 1,000,000 data points (Includes SCSN-450 Power Supply)		■	SCM-340-2-02
<b>Storage Case - Small</b>	■		SCC-210
<b>Storage Case - Medium</b>	■	■	SC-690
<b>Storage Case - Large Roller</b>	■	■	SCC-500-ENG
<b>Storage Insert - Holds Extra Sensors</b> Used with SCC-500-ENG Large Roller Case	■	■	SCC-500-INLET-ENG
<b>Power Supply</b> 120 Volt AC	■		SCSN-440
<b>Power Supply</b> 120 Volt AC		■	SCSN-450
<b>Connection Cable - Analog</b> Used between meter and sensors (3M length)	■	■	SCK-102-03-02
<b>Extension Cable - Analog</b> Used in series with connection cables (5M length)	■	■	SCK-102-05-12
<b>Connection Cable - CAN</b> Used between meter and sensors (2M, 5M, 10M lengths)	■		SCK-401-02-4F-4M SCK-401-05-4F-4M SCK-401-10-4F-4M
<b>Pressure Transducers - Analog</b> Five measurement ranges	■	■	See page C-13
<b>Pressure Transducers - CAN</b> Five measurement ranges	■		See page C-14
<b>Flow Sensors - Analog</b> Four measurement ranges	■	■	See page C-15
<b>Flow Sensors - CAN</b> Four measurement ranges	■		See page C-16
<b>Temperature Sensor</b> Used with Parker Flow Sensors or SCTA-1/4 Port Adapter (Requires standard connection cable)	■	■	SCT-150-04-02
<b>Port Adapter</b> Converts M10X1 to 1/4" male NPT thread	■	■	SCTA-1/4
<b>Tachometer - Analog</b> To measure rotational speed (0 to 10,000 RPM)	■	■	SCRPM-220
<b>Contact Adapter</b> For SCRPM-220 Tachometer	■	■	SCRPMA-001
<b>Focus Adapter</b> For SCRPM-220 Tachometer	■	■	SCRPMA-002
<b>Diagnostic Test Hose Assembly</b> (19" & 32" lengths) Used with PD style Parker Transducers and diagnostic nipples	■	■	PDH-19 PDH-32
<b>Voltage Adapter - Analog</b> Used with auxiliary sensors	■	■	SCMA-VADC-600
<b>Frequency Adapter - Analog or CAN</b>	■	■	SCMA-FCU-600

Diagnostic Equipment



Diagnostic Meters and Accessories  
Software and Data Cables



Description	The Parker Serviceman Plus	The Parker Service Master Easy	Part Number
<b>The Parker Serviceman Plus</b> Hand-held meter, 2-3 inputs (Includes SCSN-440 Power Supply)	■		SCM-155-2-05 (CAN) SCM-155-0-02 (Analog)
<b>The Parker Service Master Easy</b> Hand-held meter, 4 inputs, up to 1,000,000 data points (Includes SCSN-450 Power Supply)		■	SCM-340-2-02
<b>Data Cable</b> To connect the Serviceman Plus meter to a PC	■		SCK-315-02-36
<b>Data Cable</b> Used between the Parker Service Master Easy meter and a PC		■	SCK-315-02-34
<b>SensoWin Software</b> For data transfer from any Parker Service Master or Serviceman meter to a PC	■	■	Download from web

All Parker SensoControl hand-held diagnostic meters are equipped with the same 5-pin push-pull style connector ports. This allows analog accessories such as pressure sensors, temperature sensors, flow meters, tachometers and cables to be compatible with the Serviceman and the Parker Service Master meters.



**Temperature Sensor** (analog only) for Serviceman and the Parker Service Master Easy. Can be used with Parker flow sensors or with an SCTA-1/4 port adapter.

<b>Part Number</b>	SCT-150-04-02
<b>Accuracy</b>	+1.5% Full scale
<b>Temperature range</b>	-58°F to 257°F [-50°C to 125°C]



**SCRPM Tachometer** (analog only) for Parker Serviceman and the Service Master Easy meters. Displays a precision measurement of rotational speed. 5-pin push-pull style connector.

<b>Part Number</b>	SCRPM-220
<b>Measuring Range</b>	20 - 10,000 RPM
<b>Measuring Distance</b>	0.1 - 19.5 in
<b>Accuracy</b>	0.5% FS
<b>Excitation Voltage</b>	7 - 9 VDC
<b>Output Signal</b>	0 - 3 VDC
<b>Resolution</b>	5 RPM

### Tachometer Adapters

Contact Adapter for belt drive/wheel.	
<b>Part Number</b>	SCRPMA-001
Focus Adapter for confined areas.	
<b>Part Number</b>	SCRPMA-002



**Voltage Adapter** (analog only) for use with Auxiliary Sensors to the Parker Service Master Easy.

<b>Part Number</b>	SCMA-VADC-600
<b>Input</b>	0 - 4 A, 0 - 48 VDC
<b>Accuracy</b>	0.25% FS



**5 pin to 5 pin Cables** Flow sensor, transducer and temperature probe cables for both Serviceman and the Parker Service Master Easy.

<b>Part Number</b>	SCK-102-03-02
<b>Length</b>	10 ft (3 m)
<b>Part Number</b>	SCK-102-05-12
<b>Extension Cable</b>	16.4 ft (5 m)

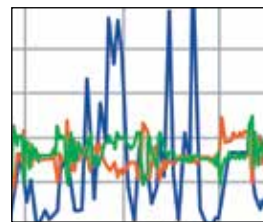

### SensoWIN™ Software

for data transfer from all Parker Service Master meters to a PC (Windows 98 and newer). SensoWin Software is included with Service Master and Serviceman meters. It is not sold separately, but is available for download from Parker.com



**Frequency Converter** Converts the signal of a connected sensor into an analog or a CAN frequency. Measurement parameters of the converter can be set via PC with the configurations software

<b>Part Number</b>	SCMA-FCU-600
--------------------	--------------

Diagnostic Equipment



**Pressure Transducer - Analog**

- Five measurement ranges: Vacuum to 8,750 PSI
- Color coded for easy identification
- Corrosion resistant stainless steel housing
- Accuracy of 0.50% Max Full Scale
- Available with PD, PDP or EMA style diagnostic couplings

**Analog Transducer Part Numbers and Technical Data**

					
	PD ** -0100	PD ** -0600	PD ** -1500	PD ** -4000	PD ** -6000
<b>Color Code</b>	Blue	Green	Yellow	Orange	Red
<b>Measuring Range (Pressure)</b>	-14.5 to 220 psi	0 to 870 psi	0 to 2175 psi	0 to 5800 psi	0 to 8700 <sup>(1)</sup> psi
<b>Measuring Range (Temp)</b>	-13°F to 221°F	-13°F to 221°F	-13°F to 221°F	-13°F to 221°F	-13°F to 221°F
<b>Max. Overload Pressure</b>	434 psi	1450 psi	3625 psi	14500 psi	14500 psi
<b>Output Signal (Volts)</b>	-0.2 to 2	0 to 3	0 to 3	0 to 3	0 to 3
<b>Response Time</b>	1 ms	1 ms	1 ms	1 ms	1 ms
<b>Excitation Voltage</b>	7-12 VDC	7-12 VDC	7-12 VDC	7-12 VDC	7-12 VDC
<b>Accuracy (max)</b>	0.50% FS	0.50% FS	0.50% FS	0.50% FS	0.50% FS

1. Maximum Rated Pressure for PD Series Couplers is 6000 psi. Maximum Rated Pressure for EMA Series Couplers is 9000 psi.

2. Analog accessories such as pressure sensors, temperature sensors, flow meters, tachometers and cables are all compatible for use with Serviceman and the Parker Service Master meters.

**“ \*\* ” in the Part Number Represents:**

- TA = PD Style
- PTA = PDP Style
- TEMA3 = EMA3 Style (Female)

**Materials of Construction**

Transducer.....Stainless steel  
 Diaphragm.....Stainless steel  
 Coupler.....Chromium-6 Free Plated steel  
 Seal.....Fluorocarbon

**Temperature Range**

Working.....-4° to 185°  
 Fluid.....-13° to 221°  
 Storage.....-40° to 257°

**Output**

Accuracy (max).....0.50% FS  
 Load.....2m ohms  
 Response time.....<1 ms  
 Output signal to noise.....0.1%FS  
 Resonant frequency.....100 KHz

**Voltage Requirement**

7 to 12 VDC excitation voltage  
 Permissible ripple.....±2% ss  
 Current requirement.....5 mA

\* V<sub>s</sub> = 7-12 VDC

\*\* Sensor Recognition

<b>Cable End (Pin Out)</b>		
Pin	Mark	Wire Colors
1	P	Yellow
2	T	White
3	*	Brown
4	GND	Green
5	SR**	Grey

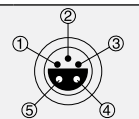







**Pressure Transducer - CAN**

- Five measurement ranges: Vacuum to 8,750 PSI
- Compatible for use with the Parker Service Master Plus only
- Color coded for easy identification
- Corrosion resistant stainless steel housing
- Accuracy of 0.50% Max Full Scale
- Available with PD, PDP or EMA style diagnostic couplings

**CAN Transducer Part Numbers and Technical Data**

					
	PD ** -0100-CAN	PD ** -0600-CAN	PD ** -1500-CAN	PD ** -4000-CAN	PD ** -6000-CAN
<b>Color Code</b>	Blue	Green	Yellow	Orange	Red
<b>Measuring Range (Pressure)</b>	-14.5 to 220 psi	0 to 870 psi	0 to 2175 psi	0 to 5800 psi	0 to 8700 <sup>(1)</sup> psi
<b>Measuring Range (Temp)</b>	-13°F to 221°F	-13°F to 221°F	-13°F to 221°F	-13°F to 221°F	-13°F to 221°F
<b>Max. Overload Pressure</b>	434 psi	1740 psi	4350 psi	11600 psi	17400 psi
<b>Response Time</b>	1 ms	1 ms	1 ms	1 ms	1 ms
<b>Excitation Voltage</b>	8-40 VDC	8-40 VDC	8-40 VDC	8-40 VDC	8-40 VDC
<b>Accuracy (max)</b>	0.50% FS	0.50% FS	0.50% FS	0.50% FS	0.50% FS

1. Maximum Rated Pressure for PD Series Couplers is 6000 psi. Maximum Rated Pressure for EMA Series Couplers is 9000 psi.  
 2. CAN accessories such as pressure transducers, flow sensors, and cables are compatible for use with the Parker Service Master Plus only.

**“ \*\* ” in the Part Number Represents:**

- TA = PD Style
- PTA = PDP Style
- TEMA3 = EMA3 Style (Female)

- Excitation Voltage**.....8-40 VDC
- Electrical Connection**.....5 pin, M 12 x 1 connection
- Port Connection**.....1/2 " BSPP
- Housing**.....Stainless Steel 1.4301
- Seal Material**.....FKM
- Ambient Temperature Range**.....-13 to 185°F
- Max. Fluid Temperature**.....221°F
- Shock Resistance**.....IEC 68-2-29
- Vibration Resistance**.....IEC 68-2-6

Cable End (Pin Out)	
Pin	Item
1	Shield
2	V <sub>s</sub> = 8...40VDC
3	GND
4	CAN High
5	CAN Low



Diagnostic Equipment

Parker Flow Sensors provide the ability to measure pressure, temperature and flow from a single test point in a hydraulic system. Constructed of light-weight aluminum, they are designed to be used with a wide variety of hydraulic fluids. This design also minimizes the effect of viscosity changes.

Flow sensors are provided with a choice of PD, PDP or EMA style diagnostic ports and are designed to be used with Serviceman Plus (Analog), Parker Service Master Plus and Parker Service Master Easy.

- Four measurement ranges: 0.2 to 160 gpm
- Accuracy of 1% FS or IR
- Provides access ports for temperature and pressure measurement
- Supplied with diagnostic coupling and temperature measurement port



Analog Flow Sensor Part Numbers								
Pressure Rating (psi)	Measuring Range	Flow Sensor with PD Nipple	Flow Sensor with PDP Nipple	Flow Sensor with EMA Nipple	Inlet/Outlet Port Configuration	Length (in.)	Height (in.)	Width (in.)
5000	0.2 – 4 gpm (1 – 15 l/min)	SCFT-0004-PD	SCFT-0004-PDP	SCFT-0004-EMA	3/4-16 ORB	5.35	4.61	1.46
5000	1 – 16 gpm (4 – 60 l/min)	SCFT-0116-PD	SCFT-0116-PDP	SCFT-0116-EMA	1 1/16-12 ORB	7.48	5.12	2.44
5000	3 – 80 gpm (10 – 300 l/min)	SCFT-0380-PD	SCFT-0380-PDP	SCFT-0380-EMA	1 5/16-12 ORB	7.48	5.28	2.44
4200	5 – 160 gpm (20 – 600 l/min)	SCFT-5160-PD	SCFT-5160-PDP	SCFT-5160-EMA	1 5/8-12 ORB	8.35	5.91	2.44

Analog Flow Sensors Technical Data	
Fluid Temperature Range	-4°F to +194°F
Ambient Temperature Range	-4°F to +122°F
Media/Compatibility	Petroleum Based Fluids (Contact factory for use with water based hydraulic fluids)
Flow Measurement Accuracy	±1.0% Actual Reading
Voltage Input	+7 to 12 VDC (Supplied by SensoControl meter)
Current Requirement	6mA
Response Time	50 ms
Viscosity Range	10 to 100 cSt

Material Specifications	
Housing	Anodized Aluminum
Turbine	Stainless Steel
Bearings	Stainless Steel
Seal Material	Nitrile
Electrical Connection	5 Pin Push-Pull Style



Parker Flow Sensors provide the ability to measure pressure, temperature and flow from a single test point in a hydraulic system. Constructed of light-weight aluminum, they are designed to be used with a wide variety of hydraulic fluids. This design also minimizes the effect of viscosity changes.

CAN flow sensors are provided with a choice of PD, PDP or EMA style diagnostic ports and are designed to be used with the Parker Service Master Plus and Serviceman Plus (CAN).



- Four measurement ranges: 0.2 to 160 gpm
- Accuracy of 1% FS or IR
- Provides access ports for temperature and pressure measurement
- Supplied with diagnostic coupling and temperature measurement port

**CAN Flow Sensor Part Numbers**

Pressure Rating (psi)	Measuring Range	Flow Sensor with PD Nipple	Flow Sensor with PDP Nipple	Flow Sensor with EMA Nipple	Inlet/Outlet Port Configuration	Length (in.)	Height (in.)	Width (in.)
5000	0.2 –4 gpm (1 – 15 l/min)	SCFT-0004-PD-CAN	SCFT-0004-PDP-CAN	SCFT-0004-EMA-CAN	3/4-16 ORB	5.35	4.61	1.46
5000	1–16 gpm (4 – 60 l/min)	SCFT-0116-PD-CAN	SCFT-0116-PDP-CAN	SCFT-0116-EMA-CAN	1 1/16-12 ORB	7.48	5.12	2.44
5000	3–80 gpm (10 – 300 l/min)	SCFT-0380-PD-CAN	SCFT-0380-PDP-CAN	SCFT-0380-EMA-CAN	1 5/16-12 ORB	7.48	5.28	2.44
4200	5–160 gpm (20 – 600 l/min)	SCFT-5160-PD-CAN	SCFT-5160-PDP-CAN	SCFT-5160-EMA-CAN	1 5/8-12 ORB	8.35	5.91	2.44

**CAN Flow Sensors Technical Data**

<b>Overload Pressure</b>	1.2 X Operating Pressure
<b>Max Fluid Temperature</b>	194°F
<b>Ambient Temperature Range</b>	14°F to +122°F
<b>Max Flow</b>	1.1 X Flow Range
<b>Pressure Drop</b> @ FS 21 cSt	21 psi (SCFT-0004) 21 psi (SCFT-0116) 58 psi (SCFT-0380) 72 psi (SCFT-5160)
<b>Flow Measurement Accuracy</b> @21 cSt	1 % FS (SCFT-0004) 1 % IR (SCFT-0116) 1 % IR (SCFT-0380) 1 % IR (SCFT-5160)
FS = Full Scale IR = Indicated Reading	
<b>Voltage Input</b>	8 to 40 VDC
<b>Response Time</b>	50 ms
<b>Filtration</b>	25 um
<b>Viscosity Range</b>	10 to 100 cSt

**Material Specifications**

<b>Housing</b>	Aluminum
<b>Wetted Parts</b>	Stainless Steel
<b>Seal Material</b>	FKM

Diagnostic Equipment



PD Series couplings provide easy connection for mechanical gauges or specialized diagnostic equipment like SensoControl®. Test port couplings provide easy connection for mechanical gauges or specialized diagnostic equipment like SensoControl. PD Series nipples can be permanently installed in the system at threaded test ports, in rigid tubing or in hose assemblies. Couplers are attached to the test instruments, allowing gauges, transducers and other test equipment to have quick access to gather critical system data.

**Features:**

- Flush-face valves minimize air inclusion and spillage
- Test port nipples are easy to clean and help to prevent system contamination
- Nipples meet ISO 15171-1 and SAE J1502 design and performance specs
- Steel, brass and stainless steel material options
- Steel material has protective zinc plating with clear trivalent chromate finish

**Applications include:**

Mobile equipment

Optional Seals Suffix*			
No suffix is required when ordering products with the standard Nitrile seals. When specifying an optional seal, refer to the following chart to determine the appropriate suffix.**			
Coupling Series	Ethylene Propylene	Fluoro-carbon	Neoprene
PD Series	W	Y	Z

\* To select proper seal materials, see Fluid Compatibility Chart in Appendices section, or contact your Parker Quick Coupling Distributor.

\*\*N/A = Not Available; STD = Standard (No Suffix Needed)

Specifications				
Body Size	1/8			
Description	PD Coupler	PD Nipple	BPD Nipple	Assembly
Part Number	PD242	PD361	BPD343Y	—
Body Material (Steel)	Carbon Steel	High Tensile Steel	Brass	—
Rated Pressure (psi)	6000	6000	300	6000
Temperature Range (STD Seals) Nitrile	-40°F to +250°F		-15°F to +400°F (Fluorocarbon)	-40°F to +250°F
Rated Flow (gpm)	—	—	—	0.8
Vacuum Data (Inches Hg)	27.5	27.5	27.5	27.5
Pressure Drop at Rated Flow (psi) with 200 SUS Fluid	—	—	—	56
Spillage at 15 PSI (ml)-Assembly	0.1 per disconnect			
Air Inclusion (ml)-Assembly	0.02 per connect			
Connect Force-Assembly	41 Lbs. (100 PSI)			
Disconnect Force-Assembly	20 Lbs. (100 PSI)			

PD Series Dust Cap	
Body Size	Dust Cap Part No.
1/8	PD6-285

Diagnostic Equipment







Couplers - Female Thread							
	Body Size	Coupler Part Number	Port End	Length	Largest Diameter	Wrench Flats	Weight (lbs.)
	1/8	PD222	1/8-27 NPTF (Female)	1.67	0.96	0.81	0.20
	1/8	PD240	7/16-20 ORB (Female)	2.12	0.96	0.81	0.26
	1/8	PD242	1/4-18 NPTF (Female)	2.12	0.96	0.81	0.25
	1/8	SSPD242Y**	1/4-18 NPTF (Female)	2.12	0.96	0.81	0.25
	1/8	PD260	9/16-18 ORB (Female)	2.12	0.96	0.81	0.24

Couplers - Male Thread							
	Body Size	Coupler Part Number	Port End	Length	Largest Diameter	Wrench Flats	Weight (lbs.)
	1/8	PD243	1/4-18 NPTF (Male)	2.26	0.96	0.81	0.23

Nipples - Female Pipe Thread							
	Body Size	Coupler Part Number	Port End	Length	Largest Diameter	Wrench Flats	Weight (lbs.)
	1/8	PD322	1/8-27 NPTF (Female)	1.48	0.65	0.81	0.06
	1/8	PD342	1/4-18 NPTF (Female)	1.63	0.87	0.81	0.12

Nipples - Male Pipe Thread							
	Body Size	Coupler Part Number	Port End	Length	Largest Diameter	Wrench Flats	Weight (lbs.)
	1/8	PD323	1/8-27 NPTF (Male)	1.55	0.79	0.69	0.17
	1/8	BPD323Y*	1/8-27 NPTF (Male)	1.44	0.72	0.63	0.17
	1/8	BPD343Y*	1/4-18 NPTF (Male)	1.48	0.79	0.69	0.06
	1/8	PD343	1/4-18 NPTF (Male)	1.48	0.79	0.69	0.06
	1/8	SSPD343Y**	1/4-18 NPTF (Male)	1.48	0.79	0.69	0.06
	1/8	PD363	3/8-18 NPTF (Male)	1.50	0.96	0.81	0.09

Nipples - Metric Thread							
	Body Size	Coupler Part Number	Port End	Length	Largest Diameter	Wrench Flats	Weight (lbs.)
	1/8	PD357	M10 x 1.0	1.10	0.79	0.69	0.17
	1/8	PD3107	M16 x 1.5	0.84	1.01	0.63	0.08
	1/8	PD3127	M18 x 1.5	0.90	1.08	0.69	0.09
	1/8	PD3147	M20 x 1.5	0.80	0.87	0.69	0.07

Nipples - Straight Thread							
	Body Size	Coupler Part Number	Port End	Length	Largest Diameter	Wrench Flats	Weight (lbs.)
	1/8	PD331	3/8-24 NPTF (Male)	1.80	0.79	0.69	0.17
	1/8	PD341	7/16-20 NPTF (Male)	1.60	0.79	0.63	0.08
	1/8	PD351	1/2-20 NPTF (Male)	1.32	0.72	0.69	0.05
	1/8	PD361	9/16-18 NPTF (Male)	1.32	0.79	0.69	0.06

\* NOTE: Add -6 to Nipple part number to include dust cap, for example PD43-6

\* BPD designates brass body, Fluorocarbon seal standard

\*\* SSPD designates 316SS body, Fluorocarbon seal standard

Diagnostic Equipment



**Nipples - Bulkhead Triple-Lok**

	Body Size	Coupler Part Number	Port End	Tube Size	Length	Largest Diameter	Wrench Flats	Weight (lbs.)
	1/8	PD345	7/16-20	1/4	2.92	0.94	0.81	0.19
	1/8	PD355	7/16-20	5/16	2.92	0.94	0.81	0.19
	1/8	PD365	7/16-20	3/8	3.00	0.94	0.81	0.20

**Nipples - Bulkhead Seal-Lok**

	Body Size	Coupler Part Number	Port End	Tube Size	Length	Largest Diameter	Wrench Flats	Weight (lbs.)
	1/8	PD346	9/16-18	1/4	2.98	0.94	0.81	-
	1/8	PD366	11/16-16	3/8	3.08	1.16	1.00	-
	1/8	PD386	13/16-16	1/2	3.18	1.30	1.12	-

**Tube End Nipples\* - Triple-Lok PD -- BTX**

	Body Size	Coupler Part Number	Tube Size	Length	Weight (lbs.)
	1/8	PD34BTX	1/4	1.64	0.10
	1/8	PD36BTX	3/8	1.66	0.09
	1/8	PD38BTX	1/2	1.17	0.12
	1/8	PD312BTX	3/4	1.39	0.27

**Tube End Nipples\* - Seal-Lok PD -- BTL**

	Body Size	Coupler Part Number	Tube Size	Length	Weight (lbs.)
	1/8	PD34BTL	1/4	2.18	0.12
	1/8	PD36BTL	3/8	2.30	0.14
	1/8	PD38BTL	1/2	1.57	0.13
	1/8	PD310BTL	5/8	1.16	0.19

\* Tube end nipples are designed to meet the performance standards of the tube or hose fitting connection, which may or may not meet SAE J1502 Standards.  
NOTE: Add -6 to Nipple part number to include dust cap, for example PD343-6





Fluid analysis is crucial in both engines and hydraulic systems as it can reveal problems with filtration and other internal components. Early detection can prevent costly repairs, unscheduled maintenance and production downtime. For the most accurate monitoring, fluid samples should be consistently taken from the same location.

Diagnostic fluid sampling products are designed to provide an easy access point for obtaining fluid samples. A permanently mounted test point eliminates the need to shut down or break lines when taking samples and reduces the chances of contamination. Fluid sampling nipples should be installed in either low pressure or return lines.

Specifications			
Body Size	Rated Pressure (psi)	Temperature Range (std seals)	Seal Material
1/8	500	-40° to +250° F	Fluorocarbon

**Couplers- Female Pipe Thread**



Body Size	Part No.	Port End	Length	Largest Diameter	Wrench Flats	Weight (lbs.)
1/8	PDFS242	1/4-18 NPTF	2.15	0.96	0.81	0.25

**Nipples**



Male Straight Thread



Male Pipe Thread

Body Size	Part No.	Port End	Length	Largest Diameter	Wrench Flats	Weight (lbs.)
1/8	BPDFS341	7/16-20 ORB	1.60	0.79	0.69	0.08
1/8	BPDFS343	1/4-18 NPTF	1.48	0.79	0.69	0.06

Dust Cap PD6-285 is recommended.

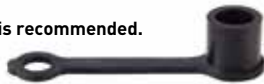

Diagnostic Equipment



When ordering Parker coupler bodies and nipples, please state the part number of each type of coupler body and each type of nipple desired. List coupler bodies and nipples as separate items rather than in combinations. Be sure to double check thread or hose sizes of items required.

Many of Parker's coupling products are available with unique non-standard options well suited to very specific applications. Examples of unusual end use applications might include: high temperatures (above 250° F), extremely caustic/corrosive solutions passing through the coupling, external/environmental corrosion situations, or other high wear and tear situations such as dragging the product along the ground. Please see the Fluid Compatibility Chart at the end of the catalog for a guide in selecting material for various media. It is always recommended that the Quick Coupling Division be contacted with any questions concerning specific product application needs.

Typically, a prefix or suffix is added to the base part number to specify a non-standard O-ring seal, or special option. The Optional Seals Suffix chart illustrates the designations.

**Please Note:** Certain couplings series have additional "Special Order Information" which should be referred to in ordering those products. If applicable to the product, "Special Order Information" is found next to the Features and Specifications charts.

**Coupler/Nipple Material**

- Prefix "B" for Brass body
- Prefix "SS" for Stainless Steel body
- Standard body material is Steel

**Optional Seals Suffix\***

No suffix is required when ordering products with the standard Nitrile seals. When specifying an optional seal, refer to the following chart to determine the appropriate suffix.\*\*

Coupling Series	Ethylene Propylene	Fluoro-carbon	Neoprene	Perfluoro-elastomer
PD Series	W	Y	Z	
PDP Series	W	Y	Z	

\*To select proper seal materials, see Fluid Compatibility Chart in Appendices section, or contact your Parker Quick Coupling Distributor.

\*\*N/A = Not Available; STD = Standard (No Suffix Needed)

NOTE: See the Specifications Table for PD and PDP Series for more information.

**Test Port Coupling-Selection Guide**

Body Size	Test Port	Valving	Material				Locking Mechanism	Standard Seal Material	Temperature Range**	Rated Pressure
			Br	SS	S	P				
1/8	PD Series	Flush Face	•	•	•		Ball	Nitrile	-40° to +250° F	6000 PSI
1/8	PDP Series	Ball			•		Ball	Nitrile	-40° to +250° F	6000 PSI
1/8	EMA3 Series	Poppet		•	•		Threads	Nitrile/Fluorocarbon	-15° to +250° F	9000 PSI

CODE: Br = Brass; SS = Stainless Steel; S = Steel; P = Plastic

\* See Fluid Compatibility chart and/or consult factory for questions regarding proper material for specific applications.

\*\*Temperature Range for standard seal material.





## Appendix

Safety Guide.....	D-2
Fluid Capability Chart.....	D-4
Fluid Capability Chart - PF Series.....	D-9
Offer of Sale.....	Inside Back Cover



## SAFETY GUIDE FOR SELECTING AND USING QUICK ACTION COUPLINGS AND RELATED ACCESSORIES



**DANGER:** Failure or improper selection or improper use of quick action couplings or related accessories can cause death, personal injury and property damage. Possible consequences of failure or improper selection or improper use of quick action couplings or related accessories include but are not limited to:

- Couplings or parts thrown off at high speed.
- High velocity fluid discharge.
- Explosion or burning of the conveyed fluid.
- Contact with suddenly moving or falling objects that are to be held in position or moved by the conveyed fluid.
- Sparking or explosion while paint or flammable liquid spraying.
- Dangerously whipping hose.
- Contact with conveyed fluids that may be hot, cold, toxic, or otherwise injurious.

Before selecting or using any Parker quick action couplings or related accessories, it is important that you read and follow the following instructions.

**1.1 Scope:** This safety guide provides instructions for selecting and using (including installing connecting, disconnecting, and maintaining) quick action couplings and related accessories (including caps, plugs, blow guns, and two way valves). This safety guide is a supplement to and is to be used with, the specific Parker publications for the specific quick action couplings and related accessories that are being considered for use.

**1.2 Fail-Safe:** Quick action couplings or the hose they are attached to can fail without warning for many reasons. Design all systems and equipment in a fail-safe mode, so that failure of the quick action coupling or hose will not endanger persons or property.

**1.3 Distribution:** Provide a copy of this safety guide to each person that is responsible for selecting or using quick action coupling products. Do not select or use quick action couplings without thoroughly reading and understanding this safety guide as well as the specific Parker publications for the products considered or selected.

**1.4 User Responsibility:** Due to the wide variety of operating conditions and uses for quick action couplings, Parker and its distributors do not represent or warrant that any particular quick action coupling is suitable for any specific end use system. This safety guide does not analyze all technical parameters that must be considered in selecting a product. The user, through its own analysis and testing, is solely responsible for:

- Making the final selection of the quick action couplings.
- Assuring that the user's requirements are met and that the use presents no health or safety hazards.
- Providing all appropriate health and safety warnings on the equipment on which the quick action couplings are used.

**1.5 Additional Questions:** Call the appropriate Parker customer service department if you have any questions or require any additional information. For the telephone numbers of the appropriate customer service department, see the Parker publication for the product being considered or used.

### 2.0 QUICK ACTION COUPLING SELECTION INSTRUCTIONS

**2.1 Pressure:** Quick action couplings selection must be made so that the published rated pressure of the coupling is equal to or greater than the maximum system pressure. Surge pressures in the system higher than the rated pressure of the coupling will shorten the quick action coupling's life.

Do not confuse burst pressure or other pressure values with rated pressure and do not use burst pressure or other pressure values for this purpose.

**2.2 Fluid Compatibility:** Quick action couplings selection must assure compatibility of the body and seal materials with the fluid media used. See the fluid compatibility chart in the Parker publication for the product being considered or used.

**2.3 Temperature:** Be certain that fluid and ambient temperatures, both steady and transient, do not exceed the limitations of the quick action couplings. Use caution and hand protection when connecting or disconnecting quick action couplings that are heated or cooled by the media they are conducting or by their environment.

**2.4 Size:** Transmission of power by means of pressurized liquid varies with pressure and rate of flow. The size of the quick action couplings and other components of the system must be adequate to keep pressure losses to a minimum and avoid damage due to heat generation or excessive fluid velocity.

**2.5 Pressurized Connect or Disconnect:** If connecting or disconnecting under pressure is a requirement, use only quick action couplings designed for that purpose. The rated operating pressure of a quick action coupling may not be the pressure at which it may be safely connected or disconnected.

**2.6 Environment:** Care must be taken to ensure that quick action couplings are either compatible with or protected from the environment (that is, surrounding conditions) to which they are exposed. Environmental conditions including but not limited to ultraviolet radiation, ozone, moisture, water, salt water, chemicals, and air pollutants can cause degradation and premature failure.

**2.7 Locking Means:** Ball locking quick action couplings can unintentionally disconnect if they are dragged over obstructions on the end of a hose or if the sleeve is bumped or moved enough to cause disconnect. Sleeves designed with flanges to provide better gripping for oily or gloved hands are especially susceptible to accidental disconnect and should not be used where these conditions exist. Sleeve lock or union (threaded) sleeve designs should be considered where there is a potential for accidental uncoupling.

**2.8 Mechanical Loads:** External forces can significantly reduce quick action couplings' life or cause failure. Mechanical loads which must be considered include excessive tensile or side loads, and vibration. Unusual applications may require special testing prior to quick action couplings selection.



## SAFETY GUIDE FOR SELECTING AND USING QUICK ACTION COUPLINGS AND RELATED ACCESSORIES



**2.9 Specifications and Standards:** When selecting quick action couplings, government, industry, and Parker specifications must be reviewed and followed as applicable.

**2.10 Vacuum:** Not all quick action couplings are suitable or recommended for vacuum service. Quick action couplings used for vacuum applications must be selected to ensure that the quick actions couplings will withstand the vacuum and pressure of the system.

**2.11 Fire Resistant Fluids:** Some fire resistant fluids require seals other than the standard nitrile used in many quick action couplings. **2.12 Radiant Heat:** Quick action couplings can be heated to destruction or loss of sealability without contact by such nearby items as hot manifolds or molten metal. The same heat source may then initiate a fire. This can occur despite the presence of cool air around the quick action couplings.

**2.13 Welding and Brazing:** Heating of plated parts, including quick action couplings and port adapters, above 450°F (232°C) such as during welding, brazing, or soldering may emit deadly gases and may cause coupling seal damage.

### 3.0 QUICK ACTION COUPLING INSTALLATION INSTRUCTIONS

**3.1 Pre-Installation Inspection:** Before installing a quick action coupling, visually inspect it and check for correct style, body material, seal material, and catalog number. Before final installation, coupling halves should be connected and disconnected with a sample of the mating half with which they will be used.

**3.2 Quick Action Coupling Halves From Other Manufacturers:** If a quick action coupling assembly is made up of one Parker half and one half from another manufacturer, the lowest pressure rating of the two halves should not be exceeded.

**3.3 Fitting Installation:** Use a thread sealant, lubricant, or a combination of both when assembling pipe thread joints in quick action couplings. Be sure the sealant is compatible with the system fluid or gas. To avoid system contamination, use a liquid or paste type sealant rather than a tape style. Use the flats provided to hold the quick action coupling when installing fittings. Do not use pipe wrenches or a vice on other parts of the coupling to hold it when installing or removing fittings as damage or loosening of threaded joints in the coupling assembly could result. Do not apply excessive torque to taper pipe threads because cracking or splitting of the female component can result.

**3.4 Caps and Plugs:** Use dust caps and plugs when quick action couplings are not coupled to exclude dirt and contamination and to protect critical surfaces from damage.

**3.5 Coupling Location:** Locate quick action couplings where they can be reached for connect or disconnect without exposing the operator to slipping, falling, getting sprayed, or coming in contact with hot or moving parts.

**3.6 Hose Whips:** Use a hose whip (a short length of hose between the tool and the coupling half) instead of rigidly mounting a coupling half on hand tools or other devices. This reduces the potential for coupling damage if the tool is dropped and provides some isolation from mechanical vibration which could cause uncoupling.

### 4.0 QUICK ACTION COUPLING MAINTENANCE INSTRUCTIONS

**4.1** Even with proper selection and installation, quick action coupling life may be significantly reduced without a continuing maintenance program. Frequency should be determined by the severity of the application and risk potential. A maintenance program must be established and followed by the user and must include the following as a minimum:

**4.2 Visual Inspection of Quick Action Couplings:** Any of the following conditions require immediate shut down and replacement of the quick action coupling:

- Cracked, damaged, or corroded quick action coupling parts.
- Leaks at the fitting, valve or mating seal.
- Broken coupling mounting hardware, especially breakaway clamps.

**4.3 Visual Inspection All Other:** The following items must be tightened, repaired or replaced as required:

- Leaking seals or port connections.
- Remove excess dirt buildup on the coupling locking means or on the interface area of either coupling half.
- Clamps, guards, and shields.
- System fluid level, fluid type and any air entrapment.

**4.4 Functional Test:** Operate the system at maximum operating pressure and check for possible malfunctions and freedom from leaks. Personnel must avoid potential hazardous areas while testing and using the system.

**4.5 Replacement Intervals:** Specific replacement intervals must be considered based on previous service life, government or industry recommendations, or when failures could result in unacceptable downtime, damage or injury risk. See instruction 1.2 above.

Additional copies of the preceding safety information can be ordered by requesting "Safety Guide For Selecting and Using Quick Action Couplings and Related Accessories," Parker Publication No. 3800-B1.0

Contact Parker's Quick Coupling Division, Minneapolis, MN.

# Fluid Compatibility Chart

## Codes

The following seal compound and body material compatibility chart is provided as an aid in selecting a specific synthetic rubber compound or body material for a particular application. Operating and environmental conditions must be considered when making the selection of a quick coupling.

Refer to the appropriate section of the catalog for Ordering Information for Seal Codes for specific products.

**To indicate a special material just add the appropriate code letter as a suffix to the catalog number of the coupler.**

It is not necessary to use the code "STD" as the standard Nitrile seal will be used when another code is not used.

For recommendations for media not listed below, please contact your Parker representative or the factory.

## Note

This chart is intended as a guide only and is not be considered as a recommendation to use Parker quick action couplings in a specific application or with a specific fluid, other factors that must be considered include but are not limited to: fluid and ambient temperature, system pressure, both operating and peak, frequency of connect and disconnect, and applicable standards or regulations.

**CODES: 1 = Satisfactory 2 = Fair 3 = Not Recommended 4 = Insufficient Data Available**

MEDIA	BODY MATERIAL				SEAL MATERIAL			
	Brass	Steel	316 S.S.	303 S.S.	Nitrile	E.P.	Fluorocarbon	Neoprene
3M FC-75	4	4	4	4	1	1	2	1
ACETAMIDE	4	4	1	2	1	1	3	1
ACETIC ACID (5%)	3	3	1	1	2	1	1	1
ACETONE	1	2	1	1	3	1	3	3
ACETOPHENONE	2	2	2	1	3	1	3	3
ACETYL ACETONE	2	2	2	2	3	1	3	3
ACETYL CHLORIDE	4	2	2	2	3	3	1	3
ACETYLENE	3	2	1	1	1	1	1	2
AIR (200 DEGREES F.)	1	2	1	1	1	1	1	1
AIR (300 DEGREES F.)	1	2	1	1	2	2	1	2
AIR (400 DEGREES F.)	1	2	1	1	3	3	1	3
ALUMINUM ACETATE	4	4	4	4	2	1	3	2
ALUMINUM BROMIDE	4	4	4	4	1	1	1	1
ALUMINUM CHLORIDE (10%)	3	3	3	3	1	1	1	1
ALUMINUM CHLORIDE (100%)	3	2	2	2	1	1	1	1
ALUMINUM FLOURIDE	3	3	3	3	1	1	1	1
ALUMINUM NITRATE	3	3	2	2	1	1	1	1
ALUMINUM SALTS	4	4	4	4	1	1	1	1
ALUMINUM SULPHATE	2	3	2	3	1	1	1	1
ALUMS (NH3,Cr,K)	4	4	4	4	1	1	3	1
AMMONIA (ANHYDROUS)	3	2	1	1	2	1	3	1
AMMONIA (COLD, GAS)	3	2	4	1	1	1	3	1
AMMONIA (HOT, GAS)	3	2	4	1	3	2	3	2
AMMONIUM CARBONATE	3	2	3	3	3	1	1	1
AMMONIUM CHLORIDE	3	3	2	3	1	1	1	1
AMMONIUM HYDROXIDE	3	3	1	2	3	1	3	1
AMMONIUM NITRATE	3	3	1	1	1	1	4	1
AMMONIUM PERSULFATE SOLUTION	3	3	1	2	3	1	4	4
AMMONIUM PHOSPHATE (MONO-, DI-, TRI-BASIC)	3	3	3	2	1	1	4	1
AMMONIUM SALTS	4	4	4	4	1	1	3	1
AMMONIUM SULFATE	3	3	2	3	1	1	3	1
AMYL BORATE	4	4	4	4	1	3	1	1
AMYL CHLORIDE	4	2	1	1	4	3	1	3
AMYL CHLORONAPHTHALENE	4	4	4	4	3	3	1	3
AMYL NAPHTHALENE	4	4	4	4	3	3	1	3
ANIMAL OIL (LARD OIL)	2	2	2	2	1	2	1	2
AROCLOR 1248	2	3	3	3	3	2	1	3
AROCLOR 1254	2	3	3	3	3	2	1	3
AROCLOR 1260	2	3	3	3	1	4	1	1
AROMATIC FUEL (50%)	4	4	4	4	2	3	1	3
ARSENIC ACID	3	3	1	1	1	1	1	1
ASPHALT	3	3	1	1	2	3	1	2
ASTM OIL, NO. 1	1	1	1	1	1	3	1	1
ASTM OIL, NO. 2	1	1	1	1	1	3	1	2

# Fluid Compatibility Chart

CODES: 1 = Satisfactory 2 = Fair 3 = Not Recommended 4 = Insufficient Data Available

MEDIA	BODY MATERIAL				SEAL MATERIAL			
	Brass	Steel	316 S.S.	303 S.S.	Nitrile	E.P.	Fluorocarbon	Neoprene
ASTM OIL, NO. 3	1	1	1	1	1	3	1	3
ASTM OIL, NO. 4	1	1	1	1	2	3	1	3
ASTM REFERENCE FUEL A	3	2	1	1	1	3	1	2
ASTM REFERENCE FUEL B	3	2	1	1	1	3	1	3
ASTM REFERENCE FUEL C	3	2	1	1	2	3	1	3
AUTOMOTIVE BRAKE FLUID	4	4	4	4	3	1	3	2
BARIUM CHLORIDE	3	3	2	3	1	1	1	1
BARIUM HYDROXIDE	3	2	2	3	1	1	1	1
BARIUM SALTS	4	4	4	4	1	1	1	1
BARIUM SULFIDE	3	2	3	3	1	1	1	1
BEER	3	3	1	1	1	1	1	1
BEET SUGAR LIQUORS	3	3	1	1	1	1	1	2
BENZALDEHYDE	3	3	2	3	3	1	3	3
BENZENE	3	2	3	3	3	3	1	3
BENZENESULFONIC ACID (10%)	3	3	3	3	3	3	1	2
BENZINE	4	4	4	4	1	3	1	2
BENZOIC ACID	3	3	3	3	3	3	1	3
BENZYL ALCOHOL	4	3	1	2	3	2	1	2
BENZYL CHLORIDE	3	3	2	3	3	3	1	3
BLEACH LIQUOR	4	4	4	4	3	1	1	2
BORAX	3	2	3	3	2	1	1	3
BORDEAUX MIXTURE	4	4	4	4	2	1	1	2
BORIC ACID	3	3	2	3	1	1	1	1
BRAKE FLUID (NON-PETROLEUM)	4	4	4	4	3	1	3	2
BRINE (SODIUM CHLORIDE)	3	3	1	1	1	1	1	1
BROMINE	4	4	4	4	3	3	1	3
BROMINE WATER	4	4	4	4	3	2	1	3
BUNKER OIL	4	4	4	4	1	3	1	3
BUTADIENE (MONOMER)	3	2	1	2	3	3	1	3
BUTANE	3	1	1	1	1	3	1	1
BUTANE (2,2, & 2,3-DIMETHYL)	4	4	4	4	1	3	1	2
BUTANOL (BUTYL ALCOHOL)	2	1	1	1	1	2	1	1
BUTTER - ANIMAL FAT	2	3	1	2	1	1	1	2
BUTYL BUTYRATE	4	4	4	4	3	1	1	3
BUTYL STEARATE	4	4	4	4	2	3	1	3
CALCINE LIQUORS	4	4	4	4	1	1	1	4
CALCIUM ACETATE	4	4	4	4	2	1	3	2
CALCIUM BISULFITE	3	3	2	3	2	1	2	2
CALCIUM CARBONATE	3	2	3	2	1	1	1	1
CALCIUM CHLORIDE	3	3	2	3	1	1	1	1
CALCIUM HYDROXIDE	3	3	2	3	1	1	1	1
CALCIUM HYPOCHLORITE	3	3	2	3	2	1	1	2
CALCIUM SALTS	4	4	4	4	1	1	1	1
CALCIUM SULFIDE	3	3	2	2	1	1	1	1
CALICHE LIQUORS	4	4	4	4	1	1	1	1
CANE SUGAR LIQUORS	4	2	1	1	1	1	1	1
CARBON BISULPHIDE	4	4	4	4	3	3	1	3
CARBON DIOXIDE	1	2	1	1	1	1	1	1
CARBON DISULFIDE	2	2	2	2	3	3	1	3
CARBON MONOXIDE	1	1	1	1	1	1	1	2
CARBON TETRACHLORIDE	2	3	1	3	2	3	1	3
CARBONIC ACID	3	3	1	2	2	1	1	1
CASTOR OIL	1	1	1	1	1	2	1	1
CELLUGUARD	4	4	4	4	1	1	1	1
CELLULUBE (NOW FYRQUEL)	4	4	4	4	3	1	1	3
CHINA WOOD OIL (TUNG OIL)	2	2	1	1	1	3	1	2
CHLORINATED SALT BRINE	4	4	4	4	3	3	1	3
CHLORINATED SOLVENTS	4	4	4	4	3	3	1	3
CHLOROBENZENE	3	3	2	3	3	3	1	3
CHLOROBUTADIENE	4	4	4	4	3	3	1	3
CHLOROFORM	3	2	2	1	3	3	1	3
CHLORPHENOL	4	4	4	4	3	3	1	3
COCONUT OIL	4	4	4	4	1	3	1	3
COPPER CHLORIDE	4	4	4	4	1	1	1	2
COPPER SALTS	4	4	4	4	1	1	1	1
COPPER SULFATE	3	3	2	3	1	1	1	1

Appendix

# Fluid Compatibility Chart

**CODES: 1 = Satisfactory 2 = Fair 3 = Not Recommended 4 = Insufficient Data Available**

MEDIA	BODY MATERIAL				SEAL MATERIAL			
	Brass	Steel	316 S.S.	303 S.S.	Nitrile	E.P.	Fluorocarbon	Neoprene
CORN OIL	2	1	1	1	1	3	1	3
COTTONSEED OIL	3	2	1	2	1	3	1	3
CREOSOLS	3	2	1	2	3	3	1	3
CREOSOTE	3	3	2	1	1	3	1	2
CRESYLIC ACID	4	2	1	2	3	3	1	3
CRUDE OIL	3	2	1	1	2	3	1	3
CUTTING OIL	4	1	1	1	1	3	1	2
DECANE	4	4	4	4	1	3	1	3
DENATURED ALCOHOL	4	4	4	4	1	1	1	1
DETERGENT, WATER SOLUTION	3	3	1	1	1	1	1	2
DIESEL FUEL	1	1	1	1	1	3	1	3
DIETHYLENE GLYCOL	3	1	1	1	1	1	1	1
DIMETHYL FORMAMIDE	4	4	1	1	2	1	3	3
DOW CHEMICAL HD50-4	4	4	4	4	4	1	3	2
DOW CORNING 200, 510, 550	4	4	4	4	2	1	1	1
DOWTHERM A,E	3	1	2	2	3	3	1	3
ETHANOL	1	3	3	3	3	1	3	1
ETHYL CHLORIDE	2	3	1	3	1	3	1	3
ETHYL HEXANOL	4	4	4	4	1	1	1	1
ETHYLENE DICHLORIDE	3	3	1	2	3	3	1	3
ETHYLENE GLYCOL	2	2	1	2	1	1	1	1
FATTY ACIDS	3	3	1	2	2	3	1	2
FREON 11	1	4	4	4	2	3	2	3
FREON 12	1	1	3	1	2	3	1	1
FREON 22	1	3	1	1	3	3	3	1
FREON 134a	1	1	1	1	2	1	4	1
FUEL OIL	3	1	1	1	1	3	1	2
GALLIC ACID	3	3	2	2	2	2	1	2
GAS, LIQUID, PROPANE (LPG)	1	3	1	1	1	3	1	2
GAS, NATURAL	2	3	1	1	1	3	1	1
GASOLINE	1	2	1	1	3	3	1	3
GELATIN	3	3	1	1	1	1	1	1
GLUCOSE	1	1	1	1	1	1	1	1
GLYCERINE (GLYCEROL)	2	1	1	1	1	1	1	1
GLYCOLS	3	2	2	2	1	1	3	1
GREEN SULFATE LIQUOR	3	3	3	3	2	1	1	2
GULF - FR FLUID (EMULSION)	4	4	4	4	1	3	1	2
GULF - FR FLUID G	4	4	4	4	1	1	1	1
GULF - FR FLUID P	4	4	4	4	3	2	2	3
HELIUM	1	1	1	1	1	1	1	1
HEPTANE	1	1	1	1	1	3	1	2
HYDRAULIC OIL (PETROLEUM BASE)	1	1	1	1	1	3	1	1
HYDRAULIC OIL (WATER BASE)	4	1	1	1	2	1	3	2
HYDRAZINE	4	3	1	1	2	1	3	2
HYDROGEN GAS	2	2	1	1	1	1	1	1
HYDROLUBE	4	4	4	4	1	1	1	2
ISO OCTANE	1	1	1	1	1	3	1	2
ISOBUTYL ALCOHOL	4	4	1	1	2	1	1	1
ISOPROPYL ALCOHOL	1	1	2	1	2	1	1	2
ISOPROPYL ETHER	1	1	1	1	2	3	3	3
JP3 AND JP4	1	1	1	1	1	3	1	3
KEROSENE	1	1	1	1	1	3	1	2
LARD, ANIMAL FAT	1	1	1	1	1	2	1	2
LINSEED OIL	3	1	1	1	1	3	1	3
LUBRICATING OIL SAE 10, 20, 30, 40, 50	1	1	1	1	1	3	1	2
MAGNESIUM SALTS	4	4	4	4	1	1	1	1
MAGNESIUM SULPHATE	3	3	2	2	1	1	1	1
MERCURY	3	3	1	1	1	1	1	1
METHANE	1	3	1	1	1	3	1	2
METHANOL	1	1	1	1	1	1	3	1
METHYL BROMIDE	4	1	1	1	2	3	1	3
METHYL CHLORIDE (DRY)	2	3	1	1	3	3	1	3
METHYL CHLORIDE (WET)	1	3	1	3	3	3	1	3
METHYL ETHER	4	4	4	4	1	3	1	3
METHYL ETHYL KETONE (MEK)	1	1	1	1	3	1	3	3
MIL-F-81912 (JP-9)	1	1	1	1	3	3	1	3

# Fluid Compatibility Chart

CODES: 1 = Satisfactory 2 = Fair 3 = Not Recommended 4 = Insufficient Data Available

MEDIA	BODY MATERIAL				SEAL MATERIAL			
	Brass	Steel	316 S.S.	303 S.S.	Nitrile	E.P.	Fluorocarbon	Neoprene
MIL-H-5606	1	1	1	1	1	3	1	2
MIL-H-6083	1	1	1	1	1	3	1	1
MIL-H-7083	1	1	1	1	1	1	2	2
MIL-H-8446 (MLO-8515)	2	1	1	1	2	3	1	1
MIL-L-2104 & 2104B	1	1	1	1	1	3	1	2
MIL-L-7808	3	2	1	1	2	3	1	3
MILK	2	1	1	1	1	1	1	1
MINERAL OILS	1	1	1	1	1	3	1	2
MLO-7277 AND MLO-7557	2	1	1	1	3	3	1	3
MOBILE HF	1	1	1	1	1	3	1	2
MONOMETHYL HYDRAZINE	4	4	4	4	2	1	4	2
NAPHTHA (COAL OR PETROLEUM)	2	1	2	2	2	3	1	3
NAPHTHALENE	2	1	2	2	3	3	1	3
NAPHTHENIC ACID	2	1	2	2	2	3	1	3
NEATSFOOT OIL	4	4	4	4	1	2	1	3
NICKEL, ACETATE	3	2	1	1	2	1	3	2
NICKEL CHLORIDE	3	3	2	2	1	1	1	2
NICKEL SALTS	4	4	4	4	1	1	1	2
NICKEL SULFATE	3	3	1	1	1	1	1	1
NITROGEN	1	1	1	1	1	1	1	1
NITROUS OXIDE	2	2	2	1	1	4	4	4
OCTYL ALCOHOL	1	1	1	1	2	3	1	2
OLIVE OIL	2	1	1	1	1	2	1	2
ORTHO-DICHLOROBENZENE	2	2	2	2	3	3	1	3
OXALIC ACID	3	3	2	1	2	1	1	2
OXYGEN (200-400 DEGREES F.)	1	1	1	1	3	3	2	3
OXYGEN, COLD	1	1	1	1	2	1	1	1
OZONE	3	3	1	1	3	1	1	3
PALMITIC ACID	1	2	1	1	1	2	1	2
PARA-DICHLOROBENZENE	2	1	1	2	3	3	1	3
PARKER O LUBE	1	1	1	1	1	3	1	1
PEANUT OIL	2	1	1	1	1	3	1	3
PENTANE (2-3-METHYL, & 2-4 DIMETHYL)	2	2	2	2	1	3	1	2
PERCHLORIC ACID -2N	3	3	2	2	3	2	1	2
PERCHLOROETHYLENE	3	2	2	2	2	3	1	3
PETROLATUM	1	1	1	1	1	3	1	2
PETROLEUM OIL, BELOW 250 DEGREES F.	1	1	1	1	1	3	1	2
PHENOL	1	1	1	1	3	3	1	3
PHOSPHORIC ACID (3 MOLAR)	3	3	2	2	1	1	1	2
PHOSPHORIC ACID (CONCENTRATED)	3	3	2	2	3	1	1	3
PHOSPHOROUS TRICHLORIDE	3	3	1	1	3	1	1	3
PICRIC ACID, MOLTEN	3	3	2	2	2	2	1	2
PICRIC ACID, WATER SOLUTION	3	3	2	2	1	1	1	1
PINE OIL	2	2	1	2	1	3	1	3
PLATING SOLUTIONS (CHROME)	1	3	1	1	4	1	1	3
PLATING SOLUTIONS (OTHER)	4	1	1	1	1	1	1	3
PNEUMATIC SERVICE	1	1	1	1	1	1	1	1
POTASSIUM ACETATE	2	1	2	2	2	1	3	2
POTASSIUM CHLORIDE	3	3	1	2	1	1	1	1
POTASSIUM CYANIDE	3	2	2	2	1	1	1	1
POTASSIUM DICHROMATE	3	1	2	2	1	1	1	1
POTASSIUM HYDROXIDE (50%)	3	2	1	2	2	1	3	2
POTASSIUM NITRATE	2	1	1	1	1	1	1	1
POTASSIUM SALTS	4	4	4	4	1	1	1	1
POTASSIUM SULFATE	3	2	1	1	1	1	1	1
PRL-HIGH TEMP. HYDR. OIL	4	4	4	4	2	3	1	2
PRODUCER GAS	2	1	1	1	1	3	1	2
PROPANE	1	3	1	1	1	3	1	2
PROPYL ACETATE	3	1	1	1	3	2	3	3
PROPYL ALCOHOL	1	1	1	1	1	1	1	1
PROPYLENE	1	1	1	1	3	3	1	3
PYDRAUL 10E	3	1	1	1	3	1	3	3
PYDRAUL A-200, C SERIES	3	1	1	1	3	3	1	3
PYDRAUL, 3 SERIES	3	1	1	1	3	1	1	3
PYROGARD 42, 43, 53, 55 (PHOSPHATE ESTER)	4	4	4	4	3	1	1	3

Appendix

# Fluid Compatibility Chart

**CODES: 1 = Satisfactory 2 = Fair 3 = Not Recommended 4 = Insufficient Data Available**

MEDIA	BODY MATERIAL				SEAL MATERIAL			
	Brass	Steel	316 S.S.	303 S.S.	Nitrile	E.P.	Fluorocarbon	Neoprene
PYROGARD D	4	4	4	4	1	3	3	2
SEA WATER (SALT WATER)	2	3	1	1	1	1	1	2
SHELL IRUS 905	4	4	4	4	1	3	1	2
SILICONE GREASES	1	1	1	1	1	1	1	1
SILVER NITRATE	3	3	1	2	2	1	1	1
SKYDROL 500, TYPE 2	3	1	1	1	3	1	3	3
SKYDROL 7000, TYPE 2	3	1	1	1	3	1	2	3
SOAP SOLUTIONS	3	3	1	1	1	1	1	2
SODIUM ACETATE	1	1	1	1	2	1	3	2
SODIUM BICARBONATE (BAKING SODA)	2	2	1	1	1	1	1	1
SODIUM BISULPHATE OR BISULPHITE	3	3	2	1	1	1	1	1
SODIUM BORATE	3	2	2	2	1	1	1	1
SODIUM CARBONATE (SODA ASH)	4	1	1	1	1	1	1	1
SODIUM CHLORIDE	3	2	2	2	1	1	1	1
SODIUM CYANIDE	3	1	1	1	1	1	4	1
SODIUM HYDROXIDE (CAUSTIC SODA, LYE)	3	2	1	2	2	1	2	2
SODIUM HYDROXIDE, 50%	3	3	1	2	2	1	2	2
SODIUM METAPHOSPHATE	2	1	2	2	1	1	1	2
SODIUM NITRATE	3	2	1	1	2	1	4	2
SODIUM PERBORATE	3	3	1	1	2	1	1	2
SODIUM PEROXIDE	3	1	2	2	2	1	1	2
SODIUM PHOSPHATES	1	3	2	1	1	1	1	2
SODIUM SALTS	4	4	4	4	1	1	1	2
SODIUM SULFATE	3	2	1	1	1	1	1	1
SODIUM SULFIDE AND SULFITE	3	3	2	3	1	1	1	1
SODIUM THIOSULFATE	3	3	1	2	2	1	1	1
SOYBEAN OIL	2	1	1	1	1	3	1	3
STANNOUS CHLORIDE (15%)	3	3	2	3	1	1	1	1
STEAM, BELOW 400 DEGREEES F.	1	3	1	1	3	1*	3	3
STODDARD SOLVENT	2	1	1	1	1	3	1	2
SUCROSE SOLUTIONS	1	1	1	1	1	1	1	2
SULFUR	2	1	1	1	3	1	1	1
SULFUR LIQUORS	1	1	1	1	2	2	1	2
SULFUR (MOLTEN)	3	3	1	1	3	3	1	3
SULFUR DIOXIDE (DRY)	3	1	1	3	3	1	3	3
SULFUR TRIOXIDE (DRY)	2	2	2	3	3	2	1	3
SUNSAFE	3	1	1	1	1	3	1	2
TANNIC ACID (10%)	1	3	2	3	1	1	1	2
TAR, BITUMINOUS	2	1	1	1	2	3	1	3
TARTARIC ACID	2	3	3	2	1	2	1	2
TERPINEOL	4	4	4	4	2	3	1	3
TERTIARY BUTYL ALCOHOL	1	1	1	1	2	2	1	2
TETRACHLOROETHANE	4	2	1	2	3	3	1	3
TETRACHLOROETHYLENE	3	2	2	4	3	3	1	3
TETRAETHYL LEAD	1	1	1	1	2	3	1	2
TETRAETHYL LEAD (BLEND)	1	1	1	1	2	3	1	3
TITANIUM TETRACHLORIDE	2	1	2	3	2	3	1	3
TOLUENE	1	1	1	1	3	3	1	3
TRANSFORMER OIL	1	1	1	1	1	3	1	2
TRANSMISSION FLUID (TYPE A)	1	1	1	1	1	3	1	2
TRICHLOROETHANE	4	2	1	4	3	3	1	3
TRICHLOROETHYLENE	3	2	2	2	3	3	1	3
TRICRESYL PHOSPHATE	4	1	2	2	3	1	2	3
TURBINE OIL #15 (MIL-L-7808A)	4	2	1	1	2	3	1	3
TURPENTINE	3	2	1	1	1	3	1	3
VARNISH	1	1	1	1	2	3	1	3
WATER	1	3	1	1	1	1	2	2
WHISKEY	1	3	1	1	1	1	1	1
WINE	1	3	1	1	1	1	1	1
WOOD OIL	4	2	1	1	1	3	1	2
XYLENE	1	2	1	1	3	3	1	3
ZINC SULFATE	3	3	2	2	1	1	1	1

# Fluid Compatibility Chart PF Series (Plastic/Polypropylene Material)

## Ratings Code:

- G** – Good to excellent. Little or no swelling, tensile or surface changes. Preferred choice.
- L** – Marginal or conditional. Noticeable effects but not necessarily indicating lack of serviceability. Further testing suggested for specific application. Very long-term effects such as stiffening or potential for crazing should be evaluated.
- P** – Poor or unsatisfactory. Not recommended without extensive and realistic testing.
- – Indicates that this was not tested.
- #** – For Teflon. Indicates good chemical resistance but potential for excessive permeation.

MEDIA	Rating
Acetaldehyde	P
Acetates	L
Acetic Acid	G
Acetic Anhydride	L
Acetone	G
Acetyl Bromide	–
Acetyl Chloride	L
Air	G
Alcohols	L
Aluminum Salts	G
Ammonia	G
Amyl Acetate	L
Aniline	G
Animal Oils	G
Arsenic Salts	L
Aromatic Hydrocarbons	–
Barium Salts	G
Benzaldehyde	L
Benzene (Benzol)	L
Benzyl Alcohol	G
Bleaching Liquors	–
Boric Acid Solution	G
Bromine	P
Butane	L
Butanol	–
Butyl Acetate	P
Calcium Salts	G
Carbon Dioxide	G
Carbon Disulfide	L
Carbon Tetrachloride	P
Caustic Potash	G
Caustic Soda	G
Chloracetic Acid	L
Chlorine (Dry)	P
Chlorine (Wet)	P
Chlorobenzene	P
Chloroform	P
Chromic Acid	G
Copper Salts	G
Cresol	L
Cyclohexanone	L
Ethers	P
Ethyl Acetate	L
Ethyl Alcohol	G
Ethylamine	L
Ethyl Bromide	–
Ethyl Chloride	P
Fatty Acids	G
Ferric Salts	G
Formaldehyde	G
Formic Acid	G
Freon	L
Gasoline	L
Glucose	G

MEDIA	Rating
Glycerine	G
Hydriodic Acid	–
Hydrochloric Acid (Conc.)	G
Hydrochloric Acid (Med. Conc.)	G
Hydrofluoric Acid	G
Hydrogen Peroxide (Conc.)	L
Hydrogen Peroxide (Dil.)	L
Hydrogen Sulfide	G
Iodine	G
Kerosene	P
Ketones	G
Lacquer Solvent	L
Lactic Acid	G
Lead Acetate	G
Linseed Oil	G
Magnesium Salts	G
Naphtha	L
Natural Gas	L
Nickel Salts	G
Nitric Acid (Conc.)	P
Nitric Acid (Dil.)	L
Nitrobenzene	G
Nitrogen Oxides	–
Nitrous Acid	G
Oils (Animal and Mineral)	L
Oils (Vegetable)	L
Oxygen	L
Perchloric Acid	L
Phenol	G
Potassium Salts	G
Pyridine	G
Silver Nitrate	G
Soap Solutions	G
Sodium Salts	G
Stearic Acid	L
Sulfur Chloride	P
Sulfuric Acid (Conc.)	L
Sulfuric Acid (Dil.)	G
Sulfurous Acid	L
Tannic Acid	G
Tanning Extracts	L
Titanium Salts	–
Toluene (Toluol)	P
Trichloroacetic Acid	G
Trichlorethylene	P
Turpentine	P
Urea	G
Uric Acid	–
Water	G
Xylene (Xylol)	P
Zinc Chloride	G





# Offer of Sale

The goods, services or work (referred to as the "Products") offered by Parker-Hannifin Corporation, its subsidiaries, groups, divisions, and authorized distributors ("Seller") are offered for sale at prices indicated in the offer, or as may be established by Seller. The offer to sell the Products and acceptance of Seller's offer by any customer ("Buyer") is contingent upon, and will be governed by all of the terms and conditions contained in this Offer of Sale. Buyer's order for any Products specified in Buyer's purchase document or Seller's offer, proposal or quote ("Quote") attached to the purchase order, when communicated to Seller verbally, or in writing, shall constitute acceptance of this offer.

**1. Terms and Conditions.** Seller's willingness to offer Products for sale or accept an order for Products is subject to the terms and conditions contained in this Offer of Sale or any newer version of the same, published by Seller electronically at [www.parker.com/sale/terms/](http://www.parker.com/sale/terms/). Seller objects to any contrary or additional terms or conditions of Buyer's order or any other document or other communication issued by Buyer.

**2. Price; Payment.** Prices stated on Seller's Quote are valid for thirty (30) days, except as explicitly otherwise stated therein, and do not include any sales, use, or other taxes or duties unless specifically stated. Seller reserves the right to modify prices to adjust for any raw material price fluctuations. Unless otherwise specified by Seller, all prices are F.C.A. Seller's facility (INCOTERMS 2010). Payment is subject to credit approval and payment for all purchases is due thirty (30) days from the date of invoice (or such date as may be specified by Seller's Credit Department). Unpaid invoices beyond the specified payment date incur interest at the rate of 1.5% per month or the maximum allowable rate under applicable law.

**3. Shipment; Delivery; Title and Risk of Loss.** All delivery dates are approximate. Seller is not responsible for damages resulting from any delay. Regardless of the manner of shipment, delivery occurs and title and risk of loss or damage pass to Buyer, upon placement of the Products with the shipment carrier at Seller's facility. Unless otherwise stated, Seller may exercise its judgment in choosing the carrier and means of delivery. No deferment of shipment at Buyer's request beyond the respective dates indicated will be made except on terms that will indemnify, defend and hold Seller harmless against all loss and additional expense. Buyer shall be responsible for any additional shipping charges incurred by Seller due to Buyer's acts or omissions.

**4. Warranty.** Seller warrants that the Products sold hereunder shall be free from defects in material or workmanship for a period of twelve (12) months from the date of delivery or 2,000 hours of normal use, whichever occurs first. All prices are based upon the exclusive limited warranty stated above, and upon the following disclaimer: **DISCLAIMER OF WARRANTY: THIS WARRANTY IS THE SOLE AND ENTIRE WARRANTY PERTAINING TO PRODUCTS PROVIDED. SELLER DISCLAIMS ALL OTHER WARRANTIES, EXPRESS AND IMPLIED, INCLUDING DESIGN, MERCHANTABILITY AND FITNESS FOR A PARTICULAR PURPOSE.**

**5. Claims; Commencement of Actions.** Buyer shall promptly inspect all Products upon receipt. No claims for shortages will be allowed unless reported to the Seller within ten (10) days of delivery. No other claims against Seller will be allowed unless asserted in writing within thirty (30) days after delivery. Buyer shall notify Seller of any alleged breach of warranty within thirty (30) days after the date the defect is or should have been discovered by Buyer. Any claim or action against Seller based upon breach of contract or any other theory, including tort, negligence, or otherwise must be commenced within twelve (12) months from the date of the alleged breach or other alleged event, without regard to the date of discovery.

**6. LIMITATION OF LIABILITY.** IN THE EVENT OF A BREACH OF WARRANTY, SELLER WILL, AT ITS OPTION, REPAIR OR REPLACE A DEFECTIVE PRODUCT, OR REFUND THE PURCHASE PRICE WITHIN A REASONABLE PERIOD OF TIME. IN NO EVENT IS SELLER LIABLE FOR ANY SPECIAL, INDIRECT, INCIDENTAL OR CONSEQUENTIAL DAMAGE ARISING OUT OF, OR AS THE RESULT OF, THE SALE, DELIVERY, NON-DELIVERY, SERVICING, USE OR LOSS OF USE OF THE PRODUCTS OR ANY PART THEREOF, OR FOR ANY CHARGES OR EXPENSES OF ANY NATURE INCURRED WITHOUT SELLER'S WRITTEN CONSENT, WHETHER BASED IN CONTRACT, TORT OR OTHER LEGAL THEORY. IN NO EVENT SHALL SELLER'S LIABILITY UNDER ANY CLAIM MADE BY BUYER EXCEED THE PURCHASE PRICE OF THE PRODUCTS.

**7. User Responsibility.** The user, through its own analysis and testing, is solely responsible for making the final selection of the system and Product and assuring that all performance, endurance, maintenance, safety and warning requirements of the application are met. The user must analyze all aspects of the application and follow applicable industry standards and Product information. If Seller provides Product or system options based upon data or specifications provided by the user, the user is responsible for determining that such data and specifications are suitable and sufficient for all applications and reasonably foreseeable uses of the Products or systems.

**8. Loss to Buyer's Property.** Any designs, tools, patterns, materials, drawings, confidential information or equipment furnished by Buyer or any other items which become Buyer's property, will be considered obsolete and may be destroyed by Seller after two (2) consecutive years have elapsed without Buyer ordering the items manufactured using such property. Seller shall not be responsible for any loss or damage to such property while it is in Seller's possession or control.

**9. Special Tooling.** A tooling charge may be imposed for any special tooling, including without limitation, dies, fixtures, molds and patterns, acquired to manufacture Products. Such special tooling shall be and remain Seller's property notwithstanding payment of any charges by Buyer. In no event will Buyer acquire any interest in apparatus belonging to Seller which is utilized in the manufacture of the Products, even if such apparatus has been specially converted or adapted for such manufacture and notwithstanding any charges paid by Buyer. Unless otherwise agreed, Seller has the right to alter, discard or otherwise dispose of any special tooling or other property in its sole discretion at any time.

**10. Buyer's Obligation; Rights of Seller.** To secure payment of all sums due or otherwise, Seller retains a security interest in all Products delivered to Buyer and this agreement is deemed to be a Security Agreement under the Uniform Commercial Code. Buyer authorizes Seller as its attorney to execute and file on Buyer's behalf all documents Seller deems necessary to perfect its security interest.

**11. Improper Use and Indemnity.** Buyer shall indemnify, defend, and hold Seller harmless from any losses, claims, liabilities, damages, lawsuits, judgments and costs (including attorney fees and defense costs), whether for personal injury, property

or incurred by Buyer, Buyer's employees, or any other person, arising out of: (a) improper selection, application, design, specification or other misuse of Products purchased by Buyer from Seller; (b) any act or omission, negligent or otherwise, of Buyer; (c) Seller's use of patterns, plans, drawings, or specifications furnished by Buyer to manufacture Products; or (d) Buyer's failure to comply with these terms and conditions. Seller shall not indemnify Buyer under any circumstance except as otherwise provided.

**12. Cancellations and Changes.** Buyer may not cancel or modify or cancel any order for any reason, except with Seller's written consent and upon terms that will indemnify, defend and hold Seller harmless against all direct, incidental and consequential loss or damage. Seller may change Product features, specifications, designs and availability.

**13. Limitation on Assignment.** Buyer may not assign its rights or obligations under this agreement without the prior written consent of Seller.

**14. Force Majeure.** Seller does not assume the risk and is not liable for delay or failure to perform any of Seller's obligations by reason of events or circumstances beyond its reasonable control (hereinafter "Events of Force Majeure"). Events of Force Majeure shall include without limitation: accidents, strikes or labor disputes, acts of any government or government agency, acts of nature, delays or failures in delivery from carriers or suppliers, shortages of materials, or any other cause beyond Seller's reasonable control.

**15. Waiver and Severability.** Failure to enforce any provision of this agreement will not invalidate that provision; nor will any such failure prejudice Seller's right to enforce that provision in the future. Invalidation of any provision of this agreement by legislation or other rule of law shall not invalidate any other provision herein. The remaining provisions of this agreement will remain in full force and effect.

**16. Termination.** Seller may terminate this agreement for any reason and at any time by giving Buyer thirty (30) days prior written notice. Seller may immediately terminate this agreement, in writing, if Buyer: (a) breaches any provision of this agreement (b) appoints a trustee, receiver or custodian for all or any part of Buyer's property (c) files a petition for relief in bankruptcy on its own behalf, or one if filed by a third party (d) makes an assignment for the benefit of creditors; or (e) dissolves its business or liquidates all or a majority of its assets.

**17. Governing Law.** This agreement and the sale and delivery of all Products are deemed to have taken place in, and shall be governed and construed in accordance with, the laws of the State of Ohio, as applicable to contracts executed and wholly performed therein and without regard to conflicts of laws principles. Buyer irrevocably agrees and consents to the exclusive jurisdiction and venue of the courts of Cuyahoga County, Ohio with respect to any dispute, controversy or claim arising out of or relating to this agreement.

**18. Indemnity for Infringement of Intellectual Property Rights.** Seller is not liable for infringement of any patents, trademarks, copyrights, trade dress, trade secrets or similar rights except as provided in this Section. Seller will defend and indemnify Buyer against allegations of infringement of U.S. patents, U.S. trademarks, copyrights, trade dress and trade secrets ("Intellectual Property Rights"). Seller will defend at its expense and will pay the cost of any settlement or damages awarded in an action brought against Buyer based on an allegation that a Product sold pursuant to this agreement infringes the Intellectual Property Rights of a third party. Seller's obligation to defend and indemnify Buyer is contingent on Buyer notifying Seller within ten (10) days after Buyer becomes aware of such allegations of infringement, and Seller having sole control over the defense of any allegations or actions including all negotiations for settlement or compromise. If a Product is subject to a claim that it infringes the Intellectual Property Rights of a third party, Seller may, at its sole expense and option, procure for Buyer the right to continue using the Product, replace or modify the Product so as to make it noninfringing, or offer to accept return of the Product and refund the purchase price less a reasonable allowance for depreciation. Notwithstanding the foregoing, Seller is not liable for claims of infringement based on information provided by Buyer, or directed to Products delivered hereunder for which the designs are specified in whole or part by Buyer, or infringements resulting from the modification, combination or use in a system of any Product sold hereunder. The foregoing provisions of this Section constitute Seller's sole and exclusive liability and Buyer's sole and exclusive remedy for infringement of Intellectual Property Rights.

**19. Entire Agreement.** This agreement contains the entire agreement between the Buyer and Seller and constitutes the final, complete and exclusive expression of the terms of sale. All prior or contemporaneous written or oral agreements or negotiations with respect to the subject matter are herein merged. The terms contained herein may not be modified unless in writing and signed by an authorized representative of Seller.

**20. Compliance with Laws.** Buyer agrees to comply with all applicable laws, regulations, and industry and professional standards of care, including those of the United Kingdom, the United States of America, and the country or countries in which Buyer may operate, including without limitation the U. K. Bribery Act, the U.S. Foreign Corrupt Practices Act ("FCPA"), the U.S. Anti-Kickback Act ("Anti-Kickback Act") and the U.S. Food Drug and Cosmetic Act ("FDCA"), each as currently amended, and the rules and regulations promulgated by the U.S. Food and Drug Administration ("FDA"), and agrees to indemnify and hold harmless Seller from the consequences of any violation of such provisions by Buyer, its employees or agents. Buyer acknowledges that it is familiar with the provisions of the U. K. Bribery Act, the FCPA, the FDA, and the Anti-Kickback Act, and certifies that Buyer will adhere to the requirements thereof. In particular, Buyer represents and agrees that Buyer will not make any payment or give anything of value, directly or indirectly to any governmental official, any foreign political party or official thereof, any candidate for foreign political office, or any commercial entity or person, for the purpose of influencing such person to purchase Products or otherwise benefit the business of Seller.



## Pioneer has been “The Farmer’s Choice” for more than sixty five years.

The Pioneer brand represents quality and value, and has become the product of choice for farmers around the globe. The original Pioneer quick coupling design is still the standard today. Over time, the product offering has expanded to include a variety of other products.

- Ball Valves
- Check Valves
- Hose Assembly Equipment
- Hydraulic Hose and Hose Fittings
- Quick Disconnect Couplings
- Thermoplastic Hose
- Tube Fittings and Adapters
- Diagnostic Equipment



Parker Hannifin Corporation  
**Pioneer Products Group**  
8145 Lewis Road  
Minneapolis, MN 55427

763-544-7781  
fax: 763-544-3418  
[www.parker.com](http://www.parker.com)



**GOODYEAR**  
RUBBER PRODUCTS, INC.

☎ 727-342-5088