

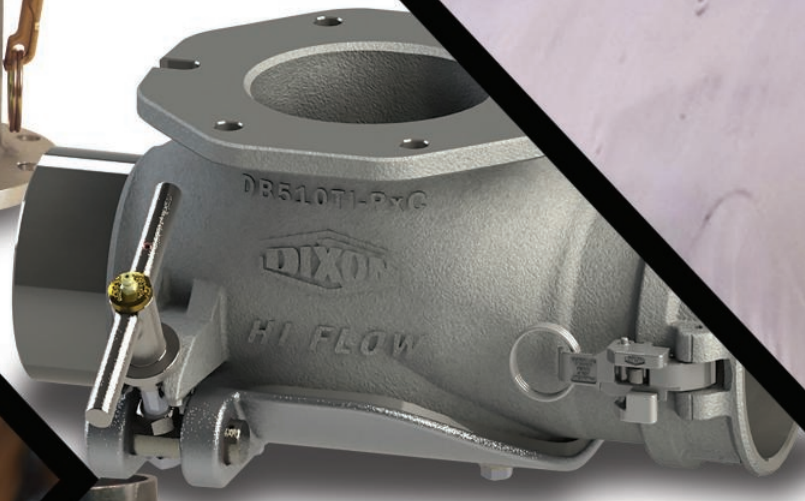

The Right Connection®

**DBD518**



[DIXONVALVE.COM](http://DIXONVALVE.COM)  
877.963.4966

**GOODYEAR**  
RUBBER PRODUCTS, INC.

727-342-5088

You can also email us at  
[GRP@goodyearrubberproducts.com](mailto:GRP@goodyearrubberproducts.com)

# Table of Contents

## Dry Bulk Products..... 2-24

Air relief valve technical information .....	2, 21
Theory of operation.....	2
Periodic inspection, cleaning and maintenance .....	2
Stationary air relief tester .....	21
Blower air relief valves (2182 series).....	3
Trailer/tank mounted vacuum relief valves .....	4-7
Fixed pressure setting.....	4
Adjustable pressure setting.....	5
PVC coated lanyards .....	5
Vacuum relief valves .....	6
Air relief valve flow rates .....	7
Products for blowers.....	8
Blower mounted swing check/air relief manifolds ...	8
TTMA series flange adaptors.....	9, 22, 24
Flange gaskets.....	9
Swing check valves .....	10-11
High Flow series .....	10
Classic 3000 series.....	11
Pneuclean™ pneumatic filtration system .....	12
Clump busters .....	13
Cam & groove in-line sight glasses.....	13
Grooved pipe connections .....	14-16
Aluminum bolt clamps.....	14
Aluminum quick connect clamps.....	15
Painted iron groove x groove bolt clamps.....	15-16
Butterfly valves .....	16-18
One-piece (iron disk/black Buna-N seals).....	16
One-piece (stainless disk/white Buna-N seals).....	16
Two-piece (stainless disk/white Buna-N seals).....	17
Composite.....	18

Hopper tees.....	19
Straight tees.....	19
Bottom drop tees.....	19
Disc fluidizers .....	20
Hose tube doors .....	21
TTMA flange adapters .....	9, 22, 24
Threaded flange adapters.....	9
Flange dimensions.....	9
Flange gaskets.....	9
Weldable flanges.....	22
Reducing flange adapters .....	24
Cam & Groove .....	23-24
Coupling x TTMA flange.....	23
Coupling with straight thread (NSPM).....	24

## Replacement Parts ..... 25-37

Blower air relief valves.....	25-28
Trailer/tank truck mounted vacuum relief valves .....	29
Swing check valves .....	30-33
Clump buster .....	34
Grooved pipe connections.....	35
Butterfly valves .....	36
Hopper tees.....	37

## Index ..... 38-40

## We Commit

- To ensure that internal and external customer needs are identified and that our products and services meet these needs.
- To fully meet and exceed the requirements of the ISO 9001 Quality Program.
- To strive for quality in each and every phase of our business.
- To exceed competitor's quality.
- To provide systems and training for all Dixon® employees.
- To create an environment that will allow each employee to do it right the first time, and accept the responsibility for quality in each and every task they perform.
- That no employee will ever be called on to do anything morally, legally or ethically wrong.

Bayco brand dry bulk products are designed for use with bulk trailers and truck blowers for the pneumatic transfer of dry bulk commodities such as powders, grains and plastic pellets. Other industrial applications are possible where pneumatic control of air or dry products is required.

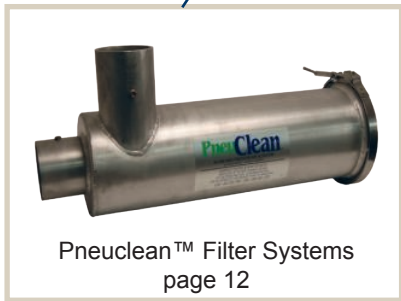
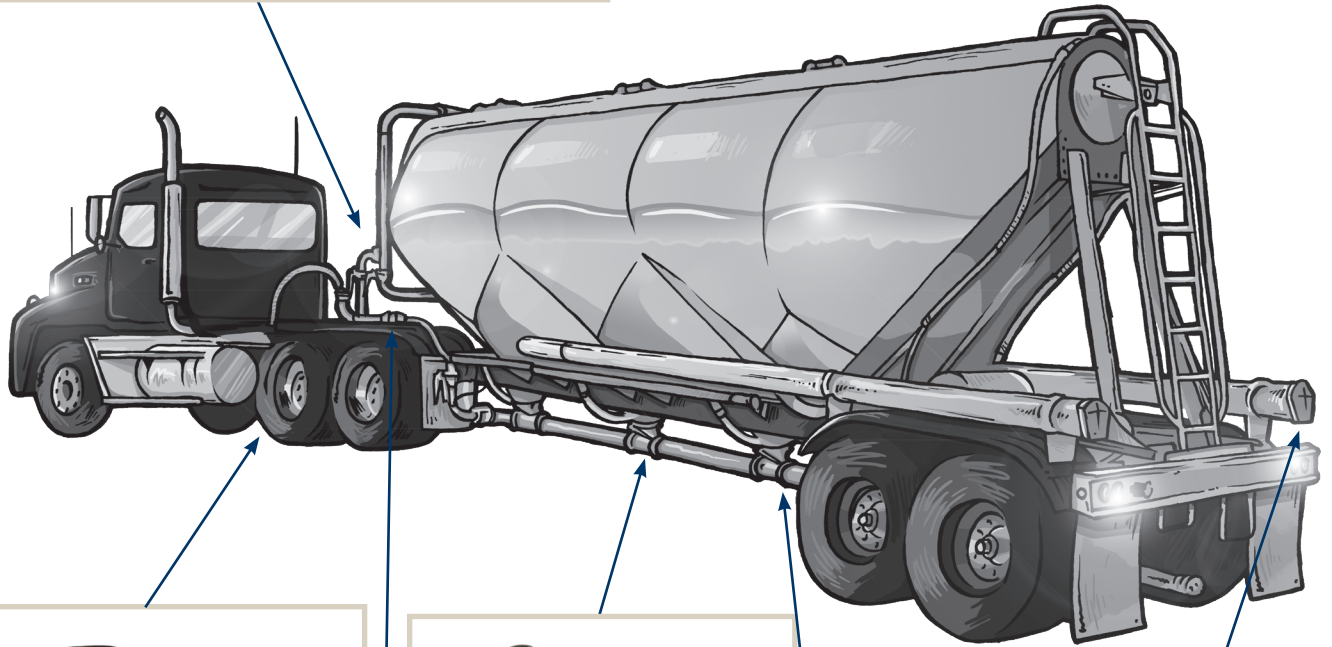

# Air Pressure Relief Valves

## Theory of Operation

All Bayco air relief valves are spring-loaded system-pressure actuated devices consisting of a valve disc held in a closed position against a valve seat by means of a spring. The pressure in the system to be protected acts on the valve disc and tends to open the valve; however, the spring load is set to ensure that at normal operating pressures, the pressure in the system is insufficient to open the valve. However, when the system pressure builds to a level where the pressure load on the valve disc is equal or near to the load exerted by the spring, the valve will begin to open. If the pressure in the system were to be held at this level, the load due to system pressure and the spring load would remain in equilibrium and the valve would be neither opened nor closed. In such circumstances the valve will tend to flutter on the valve seat and may release a small amount of air but will not be relieving significant pressure from the system. This point is known as the warning pressure, cracking pressure or hissing pressure.

If the pressure in the system continues to rise, the load acting on the face of the valve will also rise and will begin to exceed the load exerted by the spring. When the load due to system pressure exceeds the spring load, the valve will open and will remain open as long as the system pressure remains sufficient. This point is known as the opening pressure or set pressure (also referred to as rated or popping pressure). The difference between the crack pressure and opening pressure varies between valves and is related to the system flow rate. However, the two should not be confused as there is a significant difference in pressure between the two points.

If the system pressure continues to rise, the valve will continue to open and will relieve more and more air until the valve is fully open. At this point the valve will be relieving close to its maximum airflow rate; further increase in system pressure will show only relatively minor increases in flow rate. If the system pressure decreases, the relieving airflow rate will reduce and the valve will start to close. However, the valve will not fully re-seat until the pressure is below the opening pressure. This pressure is known as the Reseating Pressure and the difference between the two pressures is known as "blowdown".

In practice the valve should be matched to the system to be protected such that the maximum airflow rate of the valve is never utilized, i.e. the valve should be capable of relieving a sufficient volume flow rate of air at the opening pressure to ensure that the system pressure drops significantly. If the valve is open and the system pressure continues to rise above the opening pressure then the valve is relieving less air than is being put into the system. This is a potentially dangerous situation that may lead to over pressurization. The relieving airflow rate of an air relief valve at the maximum allowable system pressure, and ideally at the opening pressure, should be well in excess of the system input flow rate at that same pressure.

## Periodic Inspection, Cleaning and Maintenance

Dixon Bayco air relief valves are designed and built to provide accurate and consistent operation; however periodic inspection, cleaning, and maintenance of these valves is required to ensure continued trouble free service.

Dixon Bayco air relief valves consist of a spring-loaded poppet valve that seals against a rigid annular valve seat. When the system pressure reaches the valve opening pressure, the poppet lifts and system air passes under the poppet and out to atmosphere. When a sufficient volume of air has been relieved, the system pressure will drop and the poppet will re-seat.

When these valves are used in applications that subject them to particulate laden air, there is potential for contamination of the valve. Larger particles such as grains, plastic pellets etc. can get trapped between the valve seating surfaces. Applications involving fine particles such as cement, fly ash, lime, flour etc. can result in a cementing of hardened product on the valve seat or poppet surface. These situations can prevent the valve from fully re-seating, prevent it from opening and can lead to early opening or leakage from the valve.

To prevent this from occurring we advise that air/vacuum relief valves be regularly inspected, cleaned and maintained. At a minimum the valve seat and poppet sealing surface should be inspected and cleaned, and the small air vent hole in the top casting checked for blockage. The inspection, cleaning, and maintenance should be carried out with the valve removed from the system, and in a clean environment.

All relief valves are available with threaded connections. In addition 2180, A2180 and A2182 series air relief valves are available with cam and groove adapter or grooved pipe connections. These types of connections make removal and installation of the valves much easier to allow for inspections, cleaning and maintenance.



Before servicing or removing any component from the pneumatic system, the blower must be turned off and all residual air released from the system.

# Products for Blowers

## Blower Air Relief Valves

<b>Application:</b>	Designed specifically for use on tractor mounted air blowers. The 2182 air relief valves have a temperature compensated pressure relief setting to accommodate the high temperatures and dynamic air produced by the blower. If a system blockage were to occur, the valves are designed to vent to atmosphere once the valve pressure setting is achieved.
<b>Standards:</b>	<ul style="list-style-type: none"> <li>• The 2182 valve will relieve at the ordered set pressure at a temperature of <b>400°F (204°C)</b>.</li> <li>• At room temperature <b>73°F (22°C)</b> the 2182 valve will relieve approximately <b>4 PSI</b> higher than the ordered set pressure.</li> <li>• The product label shows the set relief pressure at the blower operating temperature, plus the relief pressure at <b>73°F (22°C)</b> (for testing purposes). Depending on the blower type, amount of vibration, and operating temperature a difference of observable set pressure may occur. Example: 2182-18 is set to relieve at <b>18 PSI</b> while at operating temperature. This same valve will test at <b>22 PSI</b> while at room temperature on a test bench. Both set points are listed on the label.</li> <li>• Available with 2" male or female NPT connections</li> </ul>
<b>Materials:</b>	Aluminum anodized hard coat body, white food grade silicone poppet and diaphragm
<b>Features &amp; Benefits:</b>	<ul style="list-style-type: none"> <li>• The popular pressure setting for truck mounted blowers is <b>20 PSI</b>. Valves are available for other applications with temperature compensated pressure settings of between <b>3 PSI</b> and <b>24 PSI</b>. Customer should request set pressure at time of order.</li> <li>• High relieving capacity varies between <b>800 SCFM</b> and <b>1700 SCFM</b> depending upon the chosen set pressure; for specific relief rates please refer to our graph on page 7 or contact Dixon®.</li> <li>• Installed cup seal deters tampering</li> <li>• Anodized aluminum body reduces thread galling</li> </ul>

Dry Bulk Products



2182F



2182

Part #	Connection
<b>2182F/xx</b>	2" NPTF air relief valve with special factory setting, see note xx below
<b>2182F/18</b>	2" NPTF air relief valve <b>18 PSI</b> setting
<b>2182F/20</b>	2" NPTF air relief valve <b>20 PSI</b> setting
<b>2182/xx</b>	2" NPTM air relief valve with special factory setting, see note xx below
<b>2182/18</b>	2" NPTM air relief valve <b>18 PSI</b> setting
<b>2182/20</b>	2" NPTM air relief valve <b>20 PSI</b> setting

- Request the required pressure setting when ordering (xx refers to choice of pressure setting).
- See chart on page 6 for factory pressure range offered.
- See page 21 for air relief testing equipment

# Trailer/Tank Mounted Air Relief Valves

## Fixed Pressure Setting Valves

Application:	Designed specifically for use on trailer tanks containing dry bulk products. If a system blockage were to occur the valves are designed to vent to atmosphere once the valve pressure setting is achieved. <b>Not intended for blower service (for blower service applications see the 2182 series air relief valves shown on page 3).</b> 
Standards:	2180/3180 series have a +3/-0 set pressure tolerance (valve opens at set pressure plus 3 PSI): <ul style="list-style-type: none"> <li>• 2180 are available with 2" male or female NPT, cam and groove adapter or grooved pipe connections.</li> <li>• 3180 are available only with 3" female NPT connections</li> </ul>
Materials:	Bayloy vent cowl with aluminum upper, bronze poppet with white food grade silicone diaphragm in the 2180, red silicone diaphragm in the 3180
Features & Benefits:	<ul style="list-style-type: none"> <li>• Available with a variety of pressure settings, see chart below for model specific available pressure settings. Customer should request set pressure at time of order.</li> <li>• Relieving capacity (SCFM) varies dependent upon model and pressure setting. See graph page 7, or for specific relief rates please refer to our website or contact Dixon®.</li> <li>• Installed cup seal deters tampering</li> <li>• Bayloy body helps prevent thread galling</li> <li>• PVC coated wire lanyard available for securing air relief valves with cam and groove adapter or groove pipe connections</li> </ul>



2180



2180B/15



2180V/15



3180

Valve Series	Valve Connection	Available Factory Set Pressure Range (PSI) <sup>1</sup>	Set Pressure Tolerance (PSI)	Diaphragm Material	Relieving Capacity (SCFM) <sup>2</sup>
<b>2180/xx</b>	2" female NPT	<b>2 to 25</b>	<b>+3/-0</b>	white food grade silicone	500 to 950
<b>2180/15</b>	2" NPTF air relief valve	<b>15</b>	<b>+3/-0</b>	white food grade silicone	500 to 950
<b>2180/18</b>	2" NPTF air relief valve	<b>18</b>	<b>+3/-0</b>	white food grade silicone	500 to 950
<b>2180B/15</b>	2" cam and groove adapter	<b>15</b>	<b>+3/-0</b>	white food grade silicone	500 to 950
<b>2180V/15</b>	2" grooved	<b>15</b>	<b>+3/-0</b>	white food grade silicone	500 to 950
<b>3180/xx</b>	3" female NPT	<b>4 to 30</b>	<b>+3/-0</b>	red silicone	750 to 1500

<sup>1</sup> Request the required pressure setting when ordering (xx refers to choice of pressure setting)

<sup>2</sup> Relieving capacity (SCFM) varies with set pressure, for specific rates please refer to our website or contact Dixon®

- See page 29 for repair kits
- See page 21 for air relief testing equipment

## PVC Coated Lanyards



CAL15

Part #	Description
<b>CAL15</b>	15" long PVC coated carbon steel cable, with aluminum crimp sleeves. One end is factory crimped, other end is un-crimped for field inspection.
<b>CAL25</b>	25" long PVC coated carbon steel cable, with aluminum crimp sleeves. One end is factory crimped, other end is un-crimped for field inspection.

# Trailer/Tank Mounted Air Relief Valves

## Adjustable Pressure Setting Valves

<b>Application:</b>	Designed specifically for use on trailer tanks containing dry bulk products. If a system blockage were to occur, the valves are designed to vent to atmosphere once the valve pressure setting is achieved. The advantage of the adjustable air relief valve is that the factory preset pressure can be tuned by <b>-3/+3 PSI</b> to meet tank/application specific pressure requirements (adjustments should be performed by either the tank builder or tank maintenance facility). <b>Not intended for blower service (for blower service applications see the 2182 series air relief valves shown on page 3).</b>  <b>Not Rated for ASME Coded Service Requirements</b>
<b>Standards:</b>	Valves have a +1/-0 set pressure tolerance (valve opens at set pressure plus <b>1 PSI</b> ) and are adjustable by <b>-3/+3 PSI</b> . • A2180ADJ has a 2" female NPT and A3180ADJ has a 3" female NPT connection
<b>Materials:</b>	Bayloy vent cowl with aluminum upper, bronze poppet with white food grade silicone diaphragm in the 2180, red silicone diaphragm in the 3180
<b>Features &amp; Benefits:</b>	<ul style="list-style-type: none"> <li>• Available with a variety of pressure settings, see chart below for model specific available pressure settings. Customer should request set pressure at time of order.</li> <li>• Factory preset pressure can be tuned by <b>-3/+3 PSI</b> to meet tank/application specific pressure requirements (adjustments should be performed by either the tank builder or tank maintenance facility)</li> <li>• Relieving capacity (SCFM) varies dependent upon model and pressure setting, see graph on page 7, or for specific relief rates please refer to our website or contact Dixon®</li> <li>• Installed cup seal deters tampering</li> <li>• Bayloy body helps prevent thread galling</li> </ul>

Dry Bulk Products



A2180-xxADJ



A3180-xxADJ

Valve Series	Valve Connection	Available Factory Set Pressure Range (PSI) <sup>1</sup>	Set Pressure Tolerance (PSI)	Diaphragm Material	Relieving Capacity (SCFM) <sup>2</sup>
<b>A2180/xxADJ</b>	2" female NPT	<b>9 to 30</b>	<b>+1/-0</b>	white food grade silicone	500 to 950
<b>A3180/xxADJ</b>	3" female NPT	<b>9 to 30</b>	<b>+1/-0</b>	red silicone	750 to 1500

<sup>1</sup> Request the required pressure setting when ordering (xx refers to choice of pressure setting)

<sup>2</sup> Relieving capacity (SCFM) varies with set pressure, for specific rates please refer to our website or contact Dixon®

- Relieving pressure is factory set at **71°F (21°C)**, high temperatures will affect the actual relieving pressure.
- See page 21 for air relief testing equipment

## Boss-Lock™ Coupler x Tube with 45° Cut

<b>Application:</b>	For use on trailer relief valves.
<b>Material:</b>	356T6 aluminum
<b>Features &amp; Benefits:</b>	<ul style="list-style-type: none"> <li>• Butt weld tubing</li> <li>• Buna-N gaskets standard, other gaskets available</li> <li>• All Boss-Lock™ couplers are supplied with pull-ring safety clips</li> </ul>



Part #	Description
<b>AC200TUBE</b>	2" Boss-Lock™ coupler x tube with 45° cut

# Trailer/Tank Mounted Air Relief Valves

Dry Bulk Products

## Vacuum Relief Valves

<b>Application:</b>	Designed specifically for use on trailer tanks containing dry bulk products. If a system blockage were to occur the valves are designed to open to atmosphere to help prevent the tank from imploding.
<b>Standards:</b>	These valves come with a set vacuum tolerance of +/-0.5 HG, available in 3 body sizes: <ul style="list-style-type: none"> <li>• 1½" male NPT outlet (tank connection) x 1½" female NPT inlet (atmosphere)</li> <li>• 2" male NPT outlet (atmosphere) x 2" female NPT inlet (tank connection)</li> <li>• 3" female NPT outlet (tank connection) x 3" female NPT inlet (atmosphere)</li> </ul>
<b>Materials:</b>	Bayloy body and bronze poppet
<b>Features &amp; Benefits:</b>	<ul style="list-style-type: none"> <li>• Available with a variety of vacuum settings, see chart below for model specific available pressure settings. Customer should request set pressure at time of order.</li> <li>• Relieving capacity (SCFM) varies deponent upon model and pressure setting. See graph on page 7, or for specific relief rates please refer to our website or contact Dixon®.</li> <li>• Installed bolt seal deters tampering</li> <li>• Bayloy body helps prevent thread galling</li> </ul>



1120



2120



3120

Valve Series	Valve Outlet (Tank Connection)	Valve Inlet (Atmosphere)	Available Factory Set Vacuum Range (HG) <sup>1</sup>	Set Pressure Tolerance (PSI)	Relieving Capacity (SCFM) <sup>2</sup>
<b>1120/xx</b>	1½" male NPT outlet (tank connection)	1½" male NPT inlet (atmosphere)	6 to 24	<b>+/- 0.5 HG</b>	175 to 420
<b>2120/xx</b>	2" male NPT outlet (tank connection)	2" male NPT inlet (atmosphere)	5 to 24	<b>+/- 0.5 HG</b>	280 to 600
<b>3120/xx</b>	3" female NPT outlet (tank connection)	3" female NPT inlet (atmosphere)	11 to 25	<b>+/- 0.5 HG</b>	700 to 1350
<b>3120ADJ/XX</b>	3" adjustable vacuum valve		14 to 22	<b>0</b>	700-1350

<sup>1</sup> Request the required pressure setting when ordering (xx refers to choice of pressure setting)

<sup>2</sup> Relieving capacity (SCFM) varies with set pressure, for specific rates please refer to our website or contact Dixon®

## Air Relief Valve Settings

### Pressure Relief Valves Minimum and Maximum Settings

Valve Series	Factory Setting	
	Min. Setting (PSI)	Max. Setting (PSI)
<b>2180</b>	<b>2</b>	<b>25</b>
<b>A2180ADJ</b> <sup>3</sup>	<b>9</b> <sup>3</sup>	<b>30</b> <sup>3</sup>
<b>2182</b>	<b>3</b>	<b>24</b>
<b>A2182</b>	<b>6</b>	<b>27</b>
<b>3180</b>	<b>4</b>	<b>30</b>
<b>A3180ADJ</b> <sup>3</sup>	<b>9</b> <sup>3</sup>	<b>30</b> <sup>3</sup>

### Vacuum Relief Valves Minimum and Maximum Settings

Valve Series	Factory Setting	
	Minimum Setting	Maximum Setting
<b>1120</b>	5" Hg	25" Hg
<b>2120</b>	5" Hg	24" Hg
<b>3120</b>	11" Hg	25" Hg

<sup>3</sup> Customer adjustable by a further +/- 3 PSI. Settings below 9 PSI are obtainable by turning the valve adjustment screw.

• Example for an 8 PSI setting the valve adjustment would be +4/-2, for 7 PSI +5/-1 and for 6 PSI +6/-0.

• Settings above 30 PSI are obtainable by turning the valve adjustment screw. Example for a 31 PSI setting the valve adjustment would be +2/-4 for 32 PSI +1/-5 and for 33 PSI +0/-6

# Trailer/Tank Mounted Air Relief Valves

## Air Relief Valve Flow Rates

### Flow Rate vs Vacuum

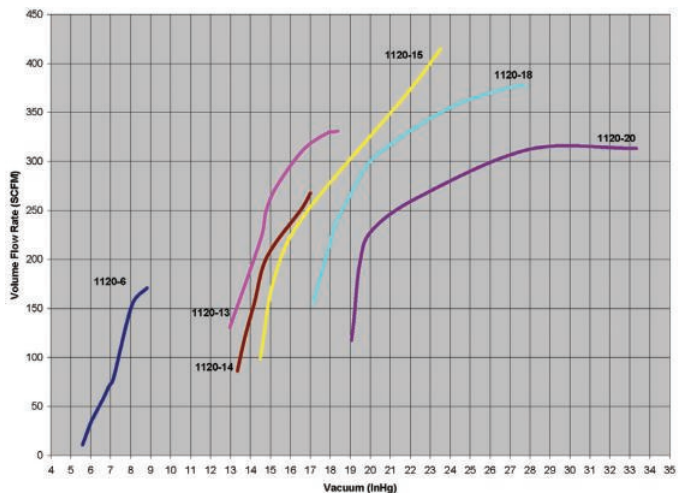

### Flow Rate vs Vacuum

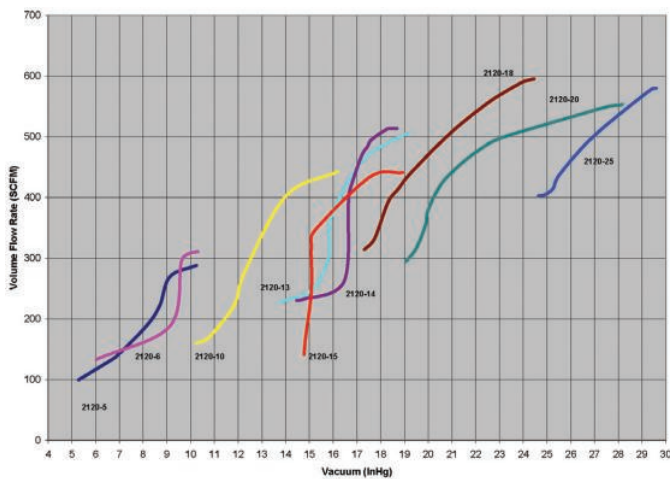

### Flow Rate vs Vacuum

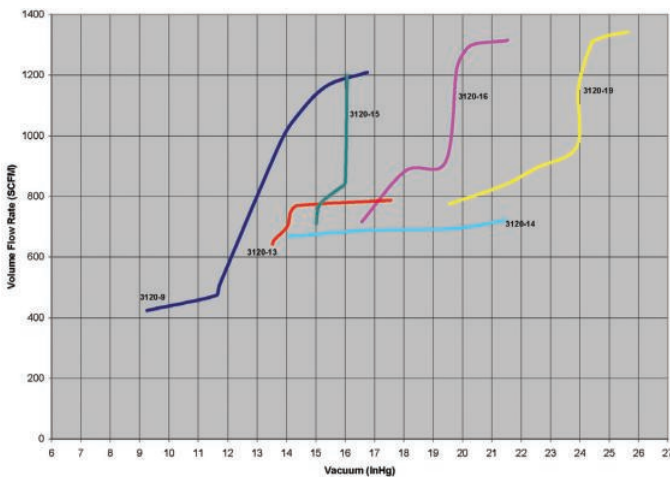

### Flow Rate vs Pressure

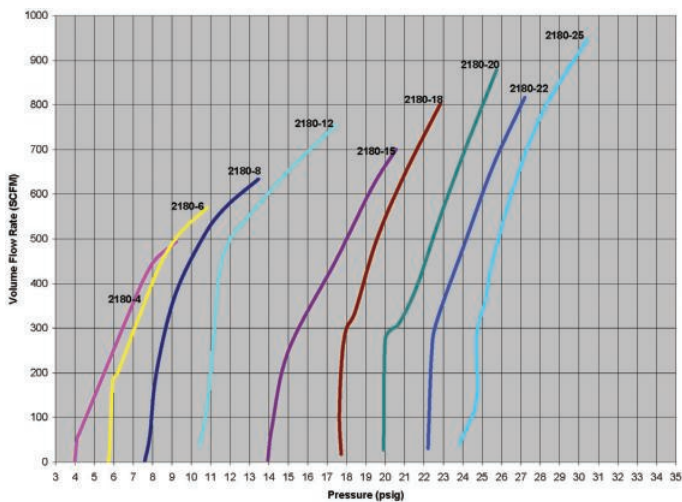

### Flow Rate vs Pressure

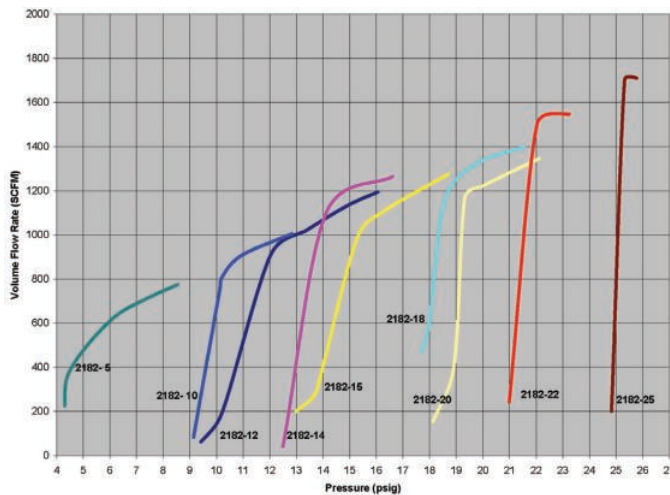

### Flow Rate vs Pressure

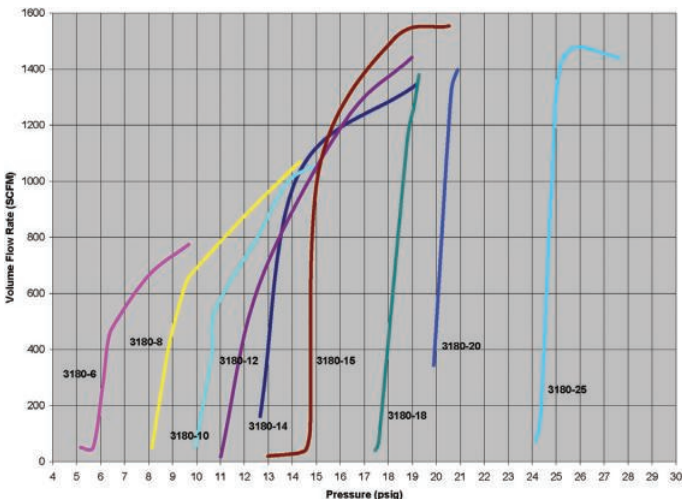

Dry Bulk  
Products

# Blower Mounted - Swing Check/Air Relief Manifold

Dry Bulk  
Products

Application:	Designed specifically for use on tractor mounted air blowers and to replace the multiple pipe connections typically used to connect the blower to a swing check and air relief valve.
Standards:	Manufactured with a 4" TTMA flange connection for fastening directly to the blower All "White" EPDM & Silicone seals are FDA compliant.
Materials:	Aluminum body, silicone flapper and lid seal <b>400°F (204°C)</b> stainless hardware
Features & Benefits:	<ul style="list-style-type: none"> <li>• Compact unit includes high flow swing check, port for air relief valve and inlet / outlet ports</li> <li>• Fastens directly to blower using available TTMA thread adapters</li> <li>• 2" FNPT port for air relief valve</li> <li>• Interchangeable inlet / outlet ports in 3" and 4" cam and groove and 4" female NPT</li> </ul>



3090MA



3090MADC-82/18

Part #	Description	Manifold Outlet Connection	Overall Length	Weight
<b>3090F</b>	swing check manifold with white silicone spring loaded flapper	4" female NPT	11½"	8.7
<b>3090M</b>	swing check manifold with white silicone spring loaded flapper	not included	9⅝"	6.2
<b>3090MS</b>	swing check manifold with white silicone spring loaded flapper and security seal	not included	9⅝"	6.6
<b>3090MA</b>	swing check manifold with white silicone spring loaded flapper	3" cam and groove adapter	12½"	7.5
<b>3090MA-DC</b>	swing check manifold with white silicone spring loaded flapper with dust cap and chain	3" cam and groove adapter	14½"	8.6
<b>3090MADC-82/18</b>	swing check manifold with white silicone spring loaded flapper with dust cap and chain, with 2182/18 air relief valve	3" cam and groove adapter	20⅞"	16.45
<b>3090MADC-82/18A</b>	swing check manifold with white silicone spring loaded flapper with dust cap and chain, with 2182/18A air relief valve	4" cam and groove adapter	20⅞"	16.45
<b>3090MADC-82/20</b>	swing check manifold with white silicone spring loaded flapper with dust cap and chain, with 2182/20 air relief valve	3" cam and groove adapter	20⅞"	16.45
<b>3090MADC-82/20A</b>	swing check manifold with white silicone spring loaded flapper with dust cap and chain, with 2182/20A air relief valve	4" cam and groove adapter	20⅞"	16.45
<b>3090MAS</b>	swing check manifold with white silicone spring loaded flapper and security kit installed	3" cam and groove adapter	12½"	7.9
<b>3090MB</b>	swing check manifold with white silicone spring loaded flapper	4" cam and groove adapter	12½"	7.6
<b>3090MBS</b>	swing check manifold with white silicone spring loaded flapper and security kit installed	4" cam and groove adapter	12½"	8.1
<b>3091MA</b>	swing check manifold with metal spring loaded flapper	3" cam and groove adapter	12½"	7.4
<b>3091MB</b>	swing check manifold with metal spring loaded flapper	4" cam and groove adapter	12½"	7.5
<b>3091MBS</b>	swing check manifold with metal spring loaded flapper and security kit installed	4" cam and groove adapter	12½"	7.6

### Swing Check Manifold Inlets / Outlets and Options

Part #	Description
<b>6000-16</b>	3" cam and groove adapter manifold outlet, requires one 3090RK1 O-ring kit
<b>6000-17</b>	4" cam and groove adapter manifold outlet, requires one 3090RK1 O-ring kit
<b>6000-20</b>	4" female NPT manifold outlet, requires one 3090RK1 O-ring kit
<b>3090RK1</b>	O-ring kit
<b>TTF4AL-3EMT</b>	3" male NPT blower to manifold inlet adapter, requires 4" TTMA gasket
<b>TTF4AL-4EMT</b>	4" male NPT blower to manifold inlet adapter, requires 4" TTMA gasket

• See page 26 for repair kits and replacement parts.

# TTMA Series Flange Adapters

<b>Application:</b>	Provides a simple and easy way to convert threaded components to standard TTMA flange configurations. TTMA flange adapters have a round TTMA flange on one end with either a male or female NPT thread on the other.
<b>Standards:</b>	Flange connections are manufactured to connect with the TTMA (Tank Truck Manufacturers Association) flange pattern, see below for flange dimensions.
<b>Material:</b>	Machined one-piece cast aluminum
<b>Features &amp; Benefits:</b>	<ul style="list-style-type: none"> <li>• Solid cast aluminum is more durable than welded fabrications</li> <li>• Compact size reduces the overall space needed for installation</li> <li>• 3" or 4" round TTMA flange pattern with either 3" or 4" male or female NPT</li> </ul>



TTF4AL-4MT



TTF4AL-3EMT



TTF4AL-4FT

Part #	Description
<b>TTF3AL-3MT</b>	3" TTMA flange x 3" male NPT, 2½" overall length
<b>TTF4AL-3MT</b>	4" TTMA flange x 3" male NPT, 2½" overall length
<b>TTF4ALHC-3MT</b>	4" TTMA flange x 3" male NPT, 2½" overall length, hardcoated
<b>TTF4AL-3EMT</b>	4" TTMA flange x 3" male NPT, 5½" overall length
<b>TTF4AL-3FT</b>	4" TTMA flange x 3" female NPT, 2½" overall length
<b>TTF4AL-4MT</b>	4" TTMA flange x 4" male NPT, 2½" overall length
<b>TTF4ALHC-4MT</b>	4" TTMA flange x 4" male NPT, 2½" overall length, hardcoated
<b>TTF4AL-4EMT</b>	4" TTMA flange x 4" male NPT, 5½" overall length
<b>TTF4AL-4FT</b>	4" TTMA flange x 4" female NPT, 2½" overall length

## Flange Gaskets

<b>Application:</b>	Creates a leak-tight connection between two bolted together flange faces.
<b>Standards:</b>	TTMA flange gaskets are manufactured to seal with flanges produced to the 3" or 4" TTMA (Tank Truck Manufacturers Association) flange pattern.
<b>Materials:</b>	PTFE, Klingsil® or Cork/Buna



Part #	Size	Description	OD	ID	Thickness	Bolt Circle
<b>Round TTMA Flange Gaskets</b>						
<b>300GTTFCB</b>	3"	TTMA - Cork/Buna	5⅝"	3½"	⅛"	4⅞"
<b>300GTTFTK</b>	3"	PTFE envelope with Klingsil® filler	5⅝"	3½"	1/16"	4⅞"
<b>300GTTFK</b>	3"	Klingsil® nylon	5⅝"	3½"	⅛"	4⅞"
<b>40321TF</b>	3"	TTMA - PTFE with soft fiber core	5 <sup>29</sup> / <sub>32</sub> "	3½"	3/32"	4⅞"
<b>400GTTFCB</b>	4"	TTMA - Cork/Buna	6⅝"	4 <sup>9</sup> / <sub>16</sub> "	⅛"	5⅞"
<b>400GTTFTK</b>	4"	PTFE envelope with Klingsil® filler	6⅝"	4 <sup>9</sup> / <sub>16</sub> "	1/16"	5⅞"
<b>400GTTFK</b>	4"	Klingsil® nylon	6⅝"	4 <sup>9</sup> / <sub>16</sub> "	⅛"	5⅞"
<b>40322TF</b>	4"	TTMA - PTFE with soft fiber core	6⅞"	4 <sup>5</sup> / <sub>8</sub> "	3/32"	5⅞"
<b>Square TTMA Flange Gaskets</b>						
<b>300GDBSQCB</b>	3"	Square TTMA - cork/Buna	4½"	3 <sup>3</sup> / <sub>8</sub> "	⅛"	---
<b>300GDBSQK</b>	3"	Square TTMA - Klingsil® nylon	4½"	3 <sup>3</sup> / <sub>8</sub> "	1/16"	---
<b>300GDBSQE</b>	3"	Square TTMA - white EPDM	4½"	3 <sup>3</sup> / <sub>8</sub> "	⅛"	---

## Round TTMA Flange Dimensions

Nominal Pipe Size	Flange OD	Aluminum Flange Thickness	Diameter of Bolt Circle	Number of Bolts	Diameter of Bolt Holes	Diameter of Bolts Used
3"	5⅝"	3/8"	4⅞"	8	7/16"	3/8"
4"	6⅝"	3/4"	5⅞"	8	7/16"	3/4"

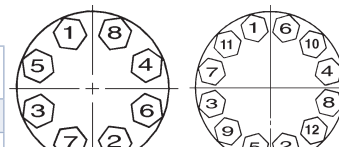

# Swing Check Valves

## Bayco High Flow Series

Dry Bulk Products

<b>Application:</b>	Often used on both the blower and trailer, designed to prevent product backflow if a product line should become plugged.
<b>Standards:</b>	Bayco High Flow series swing check valves have 2", 3" or 4" connection choices: female NPT, round TTMA flange or square TTMA flange. All white EPDM & silicone seals are FDA compliant.
<b>Materials:</b>	Aluminum body and inspection lid, stainless-steel hardware, metal-to-metal, EPDM <b>250°F (121°C)</b> or silicone seals <b>400°F (204°C)</b> are available (seal availability is dependent upon the model, see chart below for more information).
<b>Features &amp; Benefits:</b>	<ul style="list-style-type: none"> <li>• Choice of seals: metal-to metal, Buna or silicone</li> <li>• Choice of connections female NPT, round TTMA flange or square TTMA flange</li> <li>• Flapper return springs are standard</li> <li>• Huck bolted flapper assembly prevents loose parts from contaminating the product</li> <li>• Inspection lids can be removed to facilitate routine flapper assembly inspections (system must not be in service during inspections or repair)</li> <li>• Complete repairs can easily be carried out on all high flow swing check valves without removing from the tank</li> <li>• When in use the flapper can swing completely out of the air path, resulting in improved air flow and subsequently increased product flow</li> </ul>



3030SQ-SSP



3031TE



3031VIC



4040RD

Part #	Connection Type	Seal Type	Flapper Return Springs ?	Overall Length
<b>Female NPT</b>				
<b>3020TE</b>	2" female NPT both ends	white EPDM seal	yes	5 1/8"
<b>3030TE-SSP</b>	3" female NPT both ends	white silicone seal	yes	7 1/8"
<b>3031TE</b>	3" female NPT both ends	metal-to-metal seal	yes	7 1/8"
<b>4040TE</b>	4" female NPT both ends	white EPDM seal	yes	9"
<b>4041TE</b>	4" female NPT both ends	metal-to-metal seal	yes	9"
<b>4042TE</b>	4" female NPT both ends	white silicone seal	yes	9"
<b>Square TTMA Flange</b>				
<b>3020SQ</b>	2" square TTMA flange	white EPDM seal	yes	5 1/8"
<b>3030SQ-SSP</b>	3" square TTMA flange	white silicone seal	yes	6 7/8"
<b>3031SQ</b>	3" square TTMA flange	metal-to-metal seal	yes	6 7/8"
<b>Round TTMA Flange</b>				
<b>3030RD-SSP</b>	3" round TTMA flange	white silicone seal	yes	6 7/8"
<b>3031RD</b>	3" round TTMA flange	metal-to-metal seal	yes	6 7/8"
<b>4040RD</b>	4" round TTMA flange	white EPDM seal	yes	9"
<b>4041RD</b>	4" round TTMA flange	metal-to-metal seal	yes	9"
<b>4042RD</b>	4" round TTMA flange	white silicone seal	yes	9"
<b>Grooved Pipe</b>				
<b>3030VIC-SSP</b>	3" grooved end both ends	white silicone seal	yes	8"
<b>3031VIC</b>	3" grooved end both ends	metal-to-metal seal	yes	8"

- See pages 31, 32, 33 for repair kits and replacement parts
- See page 9 for TTMA flange gaskets

# Swing Check Valves

## Bayco Classic 3000 Series

<b>Application:</b>	The classic 3000 series of swing check valves are often used on both the blower and trailer.
<b>Standards:</b>	All Bayco 3000 series swing check valves have 3" connection choices: female NPT, round TTMA flange or square TTMA flange.
<b>Materials:</b>	Aluminum body, Bayloy inspection caps and flapper valve assembly. Buna <b>250°F (121°C)</b> or silicone seals <b>400°F (204°C)</b> are optional.
<b>Features &amp; Benefits:</b>	<ul style="list-style-type: none"> <li>• Choice of seals: metal-to metal, Buna or silicone</li> <li>• Choice of connections female NPT, round TTMA flange or square TTMA flange</li> <li>• Available with or without flapper return springs</li> <li>• Huck bolted flapper assembly prevents loose parts from contaminating the product</li> <li>• Inspection lids can be removed to facilitate routine flapper assembly inspections (system must not be in service during inspections or repair)</li> <li>• Limited repairs can be carried out on both threaded and square flanged units without removing from the tank, round flange units must be removed from the tank to facilitate repairs</li> <li>• For swing check valves that can be completely repaired on the tank see the Bayco High Flow 3030 Series on page 10</li> </ul>



3000TE



3001SQ-N



3000-N

Part #	Connection Type	Seal Type	Flapper Return Springs	Overall Length
<b>3000TE</b>	3" female NPT both ends	metal-to-metal seal	no	7 $\frac{1}{8}$ "
<b>3000TE-SP</b>	3" female NPT both ends	metal-to-metal seal	yes	7 $\frac{1}{8}$ "
<b>3000TE-B</b>	3" female NPT both ends	black Buna seal	no	7 $\frac{1}{8}$ "
<b>3000TE-BSP</b>	3" female NPT both ends	black Buna seal	yes	7 $\frac{1}{8}$ "
<b>3000TE-S</b>	3" female NPT both ends	white silicone seal	no	7 $\frac{1}{8}$ "
<b>3000TE-SSP</b>	3" female NPT both ends	white silicone seal	yes	7 $\frac{1}{8}$ "
<b>3001SQ-N</b>	3" square TTMA flange	metal-to-metal seal	no	6 $\frac{7}{8}$ "
<b>3001SQ-SP</b>	3" square TTMA flange	metal-to-metal seal	yes	6 $\frac{7}{8}$ "
<b>3001SQ-B</b>	3" square TTMA flange	black Buna seal	no	6 $\frac{7}{8}$ "
<b>3001SQ-BSP</b>	3" square TTMA flange	black Buna seal	yes	6 $\frac{7}{8}$ "
<b>3001SQ-S</b>	3" square TTMA flange	white silicone seal	no	6 $\frac{7}{8}$ "
<b>3001SQ-SSP</b>	3" square TTMA flange	white silicone seal	yes	6 $\frac{7}{8}$ "
<b>3000-N</b>	3" round TTMA flange	metal-to-metal seal	no	5 $\frac{5}{8}$ "
<b>3000-SP</b>	3" round TTMA flange	metal-to-metal seal	yes	5 $\frac{5}{8}$ "
<b>3000-B</b>	3" round TTMA flange	black Buna seal	no	5 $\frac{5}{8}$ "
<b>3000-BSP</b>	3" round TTMA flange	black Buna seal	yes	5 $\frac{5}{8}$ "
<b>3000-S</b>	3" round TTMA flange	white silicone seal	no	5 $\frac{5}{8}$ "
<b>3000-SSP</b>	3" round TTMA flange	white silicone seal	yes	5 $\frac{5}{8}$ "

- See pages 31, 32 for repair kits and replacement parts
- See page 9 for TTMA flange gaskets

# Pneuclean™ Pneumatic Filtration System

Dry Bulk Products

Application:	Designed to remove microscopic particles generated by blowers during pneumatic conveying of contaminant-sensitive dry bulk products. Contaminants such as iron and hydrocarbons are produced by air blowers and can adversely affect dry products such as plastic pellets and food materials. These filter units are typically mounted on dry bulk tanker trailers, but can also be mounted on the tractor. Units are placed after the blower and before the bulk storage tanker. This in-line pneumatic system is also suitable for industrial applications or wherever microscopic filtration (up to 4 microns) of impurities is required.
Standards:	Standard units employ 4" inlets and outlets, choose from schedule 40 pipe, grooved pipe, TTMA flange or 4" cam and groove adapter connections (3" plumbing can be used with available weld-on 4" x 3" cam and groove adapters). Maximum working pressure is <b>50 PSI</b> with a MERV rating of 8.
Materials:	Aluminum canister and lid, stainless V-clamp. Polyester filter material.
Features & Benefits:	<ul style="list-style-type: none"> <li>• Variety of connection types (see chart below for details)</li> <li>• Canister is heavy duty aluminum</li> <li>• Overall weight is 26 lbs.</li> <li>• Maximum air flow is 1000 CFM</li> <li>• Special cartridge-style filter element has a typical life expectancy of approximately 12 months or 2000 hours of service</li> <li>• Noise reduction filter reduces noise by 13.8 db at 600 CFM</li> <li>• FDA medium with 99.99% maximum efficiency at 4 microns</li> <li>• Back pressure <b>0.05 PSI</b></li> <li>• Quick release V clamp for easy inspection and servicing</li> </ul>



PC5000



PC5000TTTE

Part #	Description
<b>PC5000</b>	complete Pneuclean™ filtration system with 4" schedule 40 pipe inlet and outlet
<b>PC5000-002</b>	complete Pneuclean™ filtration system with 4" schedule 40 pipe inlet and outlet with Outer Perf Element
<b>PC5000AA</b>	complete Pneuclean™ filtration system with 4" cam and groove adapter inlet and outlet
<b>PC5000VV</b>	complete Pneuclean™ filtration system with 4" grooved pipe inlet and outlet
<b>PC5000TTTE</b>	complete Pneuclean™ filtration system with 4" TTMA flange inlet and 90° 4" male NPT outlet
<b>PC5003</b>	mounting bracket (sold separately, 2 required)

## Replacement Parts



PC5001



PC5001-002

Part #	Description
<b>PC5001</b>	replacement Pneuclean™ filter element, rated to <b>400°F (204°C)</b>
<b>PC5001-002</b>	complete Pneuclean filtration system with 4" schedule 40 pipe inlet and outlet with PC5001-002 element with outer perf
<b>PC5004</b>	replacement V-clamp for securing lid to body
<b>PC5005</b>	replacement lid O-ring seal
<b>PC5006</b>	replacement canister bottom gasket
<b>PC5007</b>	replacement lid

# Clump Buster

<b>Application:</b>	Designed to be used in-line for dry bulk applications where dry material may tend to clump during off-loading.
<b>Standards:</b>	Manufactured with cam and groove end configurations.
<b>Materials:</b>	Aluminum body, stainless-steel screen and V-band clamp
<b>Features &amp; Benefits:</b>	<ul style="list-style-type: none"> <li>• 4" cam and groove ends</li> <li>• Two piece housing design with V-band clamp (DB1000)</li> <li>• Stainless screen hole diameter is 7/16"</li> <li>• Seals are Buna-N</li> <li>• Bell shaped housing provides maximum flow (DB1000)</li> <li>• DB1000-SFI comes with sight glass</li> </ul>



DB1000



Inside View DB1000



DB1000-SFI

Part #	Description
<b>DB1000</b>	clump buster
<b>DB1000-SFI</b>	clump buster with sight glass

## Cam & Groove In-Line Sight Glasses

<b>Application:</b>	The cam and groove sight glasses are often connected to the dry bulk tanker's product outlet allowing the operator to visually confirm that product is flowing out of the tank.
<b>Standards:</b>	Interchanges with all product produced to commercial Item description A-A-59326B.
<b>Materials:</b>	Aluminum, acrylic sight glass, brass cam arms, Buna gaskets
<b>Features &amp; Benefits:</b>	<ul style="list-style-type: none"> <li>• Allows the operator to see product flow</li> <li>• Precision machined to rigid tolerances.</li> <li>• Durable stainless-steel cam arm pins will not rust or bind, providing strength and safety</li> <li>• Recess holds gasket firmly in place - ensures proper placement</li> <li>• Intended for dry goods only</li> </ul>

Part #	Description
<b>Coupler x Adapter</b>	
<b>3544CA</b>	4" cam and groove coupler x 4" cam and groove adapter
<b>3543CA</b>	4" cam and groove coupler x 3" cam and groove adapter
<b>3534CA</b>	3" cam and groove coupler x 4" cam and groove adapter
<b>3533CA</b>	3" cam and groove coupler x 3" cam and groove adapter
<b>Coupler x Coupler</b>	
<b>3544CC</b>	4" cam and groove coupler x 4" cam and groove coupler
<b>3543CC</b>	4" cam and groove coupler x 3" cam and groove coupler
<b>3533CC</b>	3" cam and groove coupler x 3" cam and groove coupler
<b>Adapter x Adapter</b>	
<b>3544AA</b>	4" cam and groove adapter x 4" cam and groove adapter
<b>3534AA</b>	3" cam and groove adapter x 4" cam and groove adapter
<b>3533AA</b>	3" cam and groove adapter x 3" cam and groove adapter



3543CA

# Grooved Pipe Connections

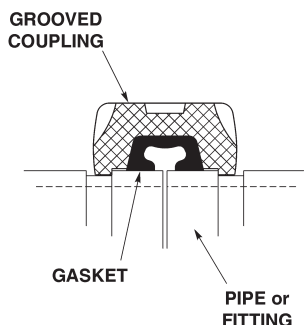

<b>Application:</b>	Designed to join two pieces of pipe together. The two pipes are butted to one another each pipe has a groove that runs the circumference of the pipe exterior. The grooved clamp has ridges that lock into the two pipe grooves and a gasket is compressed to the pipes to create a leak-tight seal. Grooved clamps are often used on pipe connections on dry bulk tankers in place of welding offering the ability to adjust, change or replace pipe sections without the need for a permanent joint such as a weld.
<b>Standards:</b>	Manufactured to fit new and existing grooved pipe connections
<b>Materials:</b>	Aluminum or coated ductile iron bodies with steel bolts/nuts, Buna seals
<b>Features &amp; Benefits:</b>	<ul style="list-style-type: none"> <li>• Constructed of rugged cast aluminum or iron</li> <li>• Maintenance is easy to perform</li> </ul>

## Aluminum Bolt Clamps



DBV-WB400

<b>Features &amp; Benefits:</b>	<ul style="list-style-type: none"> <li>• Lightweight yet rugged</li> <li>• Unlike steel groove clamps that secure the pipe ends with high clamping force against the tubing/piping walls, the Dixon® aluminum bolted clamp takes the full bolt force and locks into the groove of the tube/pipe, preventing distortion of the tube/pipe diameter</li> <li>• Precision casting and machined dimensions provide an exact fit and great appearance</li> <li>• Lock nuts prevent loosening in applications with vibration</li> <li>• White Buna seal for food applications</li> </ul>
---------------------------------	---

Size	Seal	Part #	Maximum PSI	Approximate Weight (lbs)	Bolt Torque (ft lbs)
4"	White Buna	<b>DBV-WB400</b>	<b>120</b>	1.5	50

## Painted Iron Groove x Groove Bolt Clamps



<b>Applications:</b>	Designed for applications requiring moderate internal pressure or where weight is a factor. Suitable for sand applications.
<b>Materials:</b>	Ductile iron, rust inhibiting paint
<b>Features &amp; Benefits:</b>	<ul style="list-style-type: none"> <li>• Ensures a leak-tight connection</li> </ul>

Size	Description	Part #
2"	painted iron groove x groove clamp with Buna seal	<b>L02BU</b>
3"	painted iron groove x groove clamp with Buna seal	<b>L03BU</b>
4"	painted iron groove x groove clamp with Buna seal	<b>L04BU</b>
5"	painted iron groove x groove clamp with Buna seal	<b>L05BU</b>

## Replacement Gaskets



Size	Description	Part #
2"	Buna grooved coupling replacement gasket	<b>G200T</b>
3"	Buna grooved coupling replacement gasket	<b>G300T</b>
4"	Buna grooved coupling replacement gasket	<b>G400T</b>
4"	white Buna N gasket	<b>G400N</b>
5"	Buna grooved coupling replacement gasket	<b>G500T</b>

# Grooved Pipe Connections

## Groove x Groove Painted Iron Clamps with Baylast™ Gasket

Features & Benefits:	<ul style="list-style-type: none"> <li>• Painted red</li> <li>• Baylast™ rated for biodiesel, Ethanol, diesel, gas and ULSD</li> <li>• Groove x groove</li> </ul>
----------------------	---

Size	Seal	Maximum PSI	Part #
2"	Baylast™	500	L02BL
3"	Baylast™	300	L03BL
4"	Baylast™	300	L04BL



L02BL

## Replacement Clamp Gaskets

Clamp Size	Part #	Seal	Fuel Compatibility
2"	G200BL	Baylast™ (2 orange stripes)	Gasoline and diesel, up to E100 & B100 Biofuels
3"	G300BL	Baylast™ (2 orange stripes)	
4"	G400BL	Baylast™ (2 orange stripes)	



G400BL

## Aluminum Quick Connect Clamps

Application:	Quick line clamp designed to couple groove to groove connections in dry bulk applications.
Materials:	White Buna-N split gasket, heavy duty composite handle, forged aluminum body, stainless-steel locking mechanism
Features & Benefits:	<ul style="list-style-type: none"> <li>• 4" dry bulk line clamp</li> <li>• Adjustable locking mechanism</li> <li>• Safety locking clip is included</li> <li>• 50 PSI working pressure</li> </ul>

Part #	Description
DBC400	4" aluminum groove x groove quick clamp
DBC400-P	4" aluminum pipe x pipe quick clamp
DBC400-PG	4" aluminum pipe x groove quick clamp



DBC400

## Pipe Band Clamps

Applications:	Suitable for both Food Grade and non Food Grade applications where pipe and hopper tee outlets are joined. Typically used on dry bulk cargo tank pipe connections.
Materials:	Stainless-steel band and clamps, white Buna FDA approved seals
Features & Benefits:	<ul style="list-style-type: none"> <li>• Works with both groove and straight pipe connections</li> <li>• Static conductive strap build into clamp</li> <li>• Heavy duty worm gear clamps</li> <li>• Stainless-steel support wrap improves strength</li> <li>• Band clamp retainers align clamp position</li> </ul>

Part #	Size	Description
DBPCB400	4"	stainless steel band clamp with white Buna seal



DBPCB400

# Butterfly Valves

Dry Bulk Products

<b>Application:</b>	Butterfly valves are commonly used on dry bulk tankers to control the flow of product; designed to be placed between 2 ASME/ANSI 125 or 150 lb. flanges.
<b>Materials:</b>	Aluminum bodies with iron or stainless-steel disc, polymer bushings, Buna-N (Nitrile) seals and seats, spring, stem and locking lever pin are stainless-steel, aluminum handle and throttling plate.
<b>Features &amp; Benefits:</b>	<ul style="list-style-type: none"> <li>• Rugged cast aluminum</li> <li>• Flange gaskets are not required; the valves elastomer seat also doubles as the flange gasket.</li> <li>• Handles are high strength 713 aluminum, with a retrogressive re-aging process which creates as stronger handle than the cast iron handle which are commonly used in the industry</li> <li>• Iron or stainless discs are standard for superior wear resistance</li> <li>• FDA approved black or white Buna-N seals, <b>-20°F to 275°F (-29°C to 135°C)</b></li> </ul>

## Butterfly Valve Dimensions

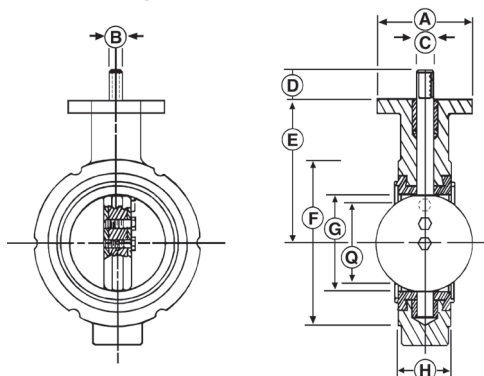

Size	A	B	C	D	E	F	G	H	Q	Weight (lbs.)
2"	4.000	0.375	0.563	1.250	3.938	4.125	2.125	1.625	1.688	3
3"	4.000	0.375	0.563	1.250	4.875	5.375	3.125	1.750	2.875	5
4"	4.000	0.438	0.625	1.250	6.000	6.875	4.125	2.000	3.875	8
5"	4.000	0.438	0.625	1.250	6.000	7.625	5.188	2.125	5.000	9
6"	4.000	0.438	0.625	1.250	6.625	8.750	6.125	2.125	6.000	9
8"	6.000	0.500	0.750	1.250	8.313	11.000	8.125	2.500	8.000	--
10"	6.000	0.625	0.875	1.250	9.125	13.375	10.125	2.500	10.000	--

- All dimensions are given in inches
- "Q" dimension is the minimum allowable inside diameter of the pipe or mating flange

## One-Piece Aluminum Body with Iron Disc and Black Buna-N Seals



DB4-400-1500



4-480-1500

### With Integrated Notch Plate

Size	Description	Complete Valve Part # <sup>1</sup>
2"	125/150# flange	<b>2-400-1500</b>
3"	125/150# flange	<b>DB3-400-1500</b>
4"	125/150# flange	<b>DB4-400-1500</b>
4"	TTMA	<b>4A-400-1500</b>
5"	125/150# flange	<b>DB5-400-1500</b>
6"	125/150# flange	<b>DB6-400-1500</b>
8"	125/150# flange	<b>8-400-1500</b>

Size	Description	Complete Valve Part # <sup>1</sup>
4"	125/150# flange	<b>4-480-1500</b>
4"	TTMA	<b>4A-480-1500</b>
5"	125/150# flange	<b>5-480-1500</b>
6"	125/150# flange	<b>6-480-1500</b>

# Butterfly Valves

## One-Piece Aluminum Body with Stainless-Steel Disc and White Buna-N Seal



DB-400-3501



4-480-3501  
with integrated notch plate

Size	Description	Complete Valve Part # <sup>1</sup>
3"	125/150# flange	<b>DB3-400-3501</b>
4"	125/150# flange	<b>DB4-400-3501</b>
4"	TTMA	<b>4A-400-3501</b>
5"	125/150# flange	<b>DB5-400-3501</b>
6"	125/150# flange	<b>6-400-3501</b>

Valve Size	Description	Complete Valve Part # <sup>1</sup>
4"	125/150# flange	<b>4-480-3501</b>
4"	TTMA	<b>4A-480-3501</b>
5"	125/150# flange	<b>5-480-3501</b>
6"	125/150# flange	<b>6-480-3501</b>

<sup>1</sup> Handle kits are sold separately.

## Two-Piece Aluminum Body with Stainless-Steel Disc and White Buna-N Seal

### Features & Benefits:

- Designed specifically for pneumatic conveying and abrasive applications
- Seat ID matches the ID of Schedule 40 pipe, resulting in smoother product flow
- Two-piece split body design simplifies field maintenance by eliminating the need for special tools

Size	Description	Complete Valve Part # <sup>1</sup>
3"	125/150# flange	<b>3-380-828501</b>
4"	125/150# flange	<b>4-380-828U501</b>
5"	125/150# flange	<b>5-380-828U501</b>
6"	125/150# flange	<b>6-380-828U501</b>



3-380-828501

<sup>1</sup> Handle kits are sold separately.

## Aluminum Butterfly Valve Handle Kits

Size	Description	Material	Part #
2-3"	10 position handle and throttle plate	steel	<b>DB237-23-10</b>
3-6"	5 position handle and throttle plate	aluminum	<b>DB206-46-5</b>
4-6"	10 position handle and throttle plate	steel	<b>DB237-46-10</b>
8"	10 position handle and throttle plate	aluminum	<b>DB206-810</b>
10"	10 position handle and throttle plate	aluminum	<b>DB206-1010</b>

# Butterfly Valves

<b>Application:</b>	Composite butterfly valves are commonly used on dry bulk cargo tankers to control the flow of product.
<b>Materials:</b>	Composite bodies with iron, aluminum or stainless-steel discs and white Baylast™ rubber seats.
<b>Features:</b>	<ul style="list-style-type: none"> <li>Reinforced composite body valves are a rugged lightweight alternative to the heavier, more expensive aluminum valves</li> <li>Bayco proven field reliability and corrosion free design</li> <li>Drop in replacement to upgrade existing aluminum valves</li> <li>Weight reduction allows for increased payload</li> </ul>
<b>Specifications:</b>	Handle kits are sold separately, choose aluminum or iron.

## Composite Butterfly Valves



DB3-900-501



DB5-900-301



DB5-900-501



DB6-900-501

Part #	Connection Type	Disc Material	Baylast™ Seat Color
<b>DB3-900-150</b>	3" composite butterfly valve	iron	black
<b>DB3-900-301</b>	3" composite butterfly valve	aluminum	white
<b>DB3-900-501</b>	3" composite butterfly valve	stainless-steel	white
<b>DB4-900-150</b>	4" composite butterfly valve	iron	black
<b>DB4-900-301</b>	4" composite butterfly valve	aluminum	white
<b>DB4-900-501</b>	4" composite butterfly valve	stainless-steel	white
<b>DB5-900-150</b>	5" composite butterfly valve	iron	black
<b>DB5-900-301</b>	5" composite butterfly valve	aluminum	white
<b>DB5-900-501</b>	5" composite butterfly valve	stainless-steel	white
<b>DB6-900-150</b>	6" composite butterfly valve	iron	black
<b>DB6-900-301</b>	6" composite butterfly valve	aluminum	white
<b>DB6-900-501</b>	6" composite butterfly valve	stainless-steel	white

## Composite Butterfly Valve Handle Kits

Part #	Size	Description	Material
<b>DB206-23-5</b>	2-3"	5 position handle and throttle plate	aluminum
<b>DB206-46-5</b>	4-6"	5 position handle and throttle plate	aluminum

# Hopper Tees

<b>Application:</b>	Straight and bottom drop tees are used at the base of dry bulk tank hoppers. With straight tees the dry bulk product is unloaded utilizing a blower generated pneumatic flow through the tee and air pressure on top of the hopper. The bottom drop tee can be utilized like the straight tee by using pneumatic conveyance or can be used for gravity unloading of the dry goods by opening the drop door on the base of the tee.
<b>Standards:</b>	Dimensionally interchangeable with industry standard offerings. Flanged to the tank hopper and grooved or pipe connection ends.
<b>Materials:</b>	Aluminum or Baycast Iron Alloy
<b>Features &amp; Benefits:</b>	<ul style="list-style-type: none"> <li>• Straight tees are cast as one-piece</li> <li>• High unloading rates and reduced flow turbulence</li> <li>• Bottom drop tees have easy to use swing out bottom drop door</li> </ul>



DB500TA



DB500LTA



DB600TA



DB600LTA



DB605LTA



DB510TI-VXP



DB510TI-PXC



DB510TI-PXP

Part #	Connection Type	Low Profile	Material		Overall Height	Overall Length
			Aluminium	Iron		
<b>Straight Tees</b>						
<b>DB500TA</b>	5" x 4" straight tee - groove x groove		✓		6.438	13.875
<b>DB600TA</b>	6" x 6" straight tee - groove x groove		✓		7.000	13.875
<b>DB500TI</b>	5" x 4" straight tee - pipe x pipe			✓	6.5625	13.875
<b>DB500TI-PXV</b>	5" x 4" straight tee - pipe x groove			✓	6.5625	13.875
<b>DB500TI-VXV</b>	5" x 4" straight tee - groove x groove			✓	6.5625	13.875
<b>DB500LTA</b>	5" x 4" straight tee - groove x groove low profile	✓	✓		6.187	13.875
<b>DB600LTA</b>	6" x 6" straight tee - groove x groove low profile	✓	✓		5.063	13.875
<b>DB605LTA</b>	6" x 5" straight tee - groove x groove low profile	✓	✓		6.094	13.875
<b>Bottom Drop Tees</b>						
<b>DB510TA</b>	5" x 4" drop tee - groove x groove		✓		7.625	13.875
<b>DB510TI</b>	5" x 4" drop tee - groove x groove			✓	7.639	13.875
<b>DB510TI-PXP</b>	5" x 4" drop tee - pipe x pipe			✓	7.639	13.875
<b>DB510TI-PXT</b>	5" x 4" drop tee - pipe to NPI 4" male thread			✓	7.639	13.875
<b>DB510TI-PXV</b>	5" x 4" drop tee - pipe x groove			✓	7.639	13.875
<b>DB510TI-VXP</b>	5" x 4" drop tee - groove x pipe			✓	7.639	13.875
<b>DB510TI-VXC</b>	5" x 4" drop tee - groove x cam & groove coupler			✓	7.623	15.593
<b>DB510TI-PXC</b>	5" x 4" drop tee - pipe x cam & groove coupler			✓	7.623	15.593
<b>DB510TI-VXT</b>	5" x 4" drop tee - groove to NPI 4" male thread			✓	7.639	13.875
<b>DB610TI-PXP</b>	6" x 4" drop tee - pipe to pipe			✓	7.265	13.975
<b>DB610TI-PXT</b>	6" X 4" drop tee - pipe x thread			✓	7.265	13.975
<b>DB610TI-PXV</b>	6" x 4" drop tee - pipe to groove			✓	7.265	13.975
<b>DB610TI-VXP</b>	6" x 4" drop tee - groove to pipe			✓	7.265	13.975
<b>DB610TI-VXT</b>	6" x 4" drop tee - groove x thread			✓	7.265	13.975
<b>DB610TI-VXV</b>	6" x 4" drop tee - groove to groove			✓	7.265	13.975

# Disk Fluidizer

<b>Application:</b>	Designed to provide the optimum amount of air volume needed for efficient pneumatic unloading of bulk trailers, allowing more airflow, less back pressure and higher unloading rates.
<b>Features &amp; Benefits:</b>	<ul style="list-style-type: none"> <li>• Seals completely to hopper or wear plate to stop the back flow of product into the aeration lines, even when flood loading</li> <li>• Durable, food grade silicone resists hardening, cracking or tearing</li> <li>• Robust design does not have snap retention legs that can break off or flimsy disks that crack and wear prematurely</li> <li>• Fluidizer component parts can withstand operating temperatures up to <b>350°F (177°C)</b></li> </ul>

## Commonly Used Fluidizer Kits

Part #	Description
<b>Typical kits for aluminum trailers. If used to haul abrasive products like sand or cement use hopper savers to protect from wear on the aluminum hopper.</b>	
111111	1-port assembly, includes blue silicone disk, grey stem hopper saver, blue silicone manifold gasket, 1-port grey manifold, tee handle
111131	3-port assembly, includes blue silicone disk, grey stem hopper saver, blue silicone manifold gasket, 3-port grey manifold, tee handle
<b>These are typical kits used in steel trailers. (Do not include hopper savers)</b>	
113111	1-port assembly, includes blue silicone disk, grey stem, blue silicone manifold gasket, 1-port grey manifold, tee handle
113131	3-port assembly, includes blue silicone disk, grey stem, blue silicone manifold gasket, 3-port grey manifold, tee handle
<b>These are standard kits used in Heil trailers</b>	
111141	1-port assembly, includes blue silicone disk, grey stem hopper saver, blue silicone manifold gasket, 1-port clear manifold, tee handle
111161	3-port assembly, includes blue silicone disk, grey stem hopper saver, blue silicone manifold gasket, 3-port clear manifold, tee handle

## Fluidizer Components



4124



4125



4134



4127



4122



4623



4129

Part #	Description
4124	blue silicone fluidizer disk (food grade)
4134	white silicone fluidizer disk (food grade)
4125	grey stem with brass insert
4135	natural stem with stainless-steel insert
4155	aluminum stem
4157	carbon steel stem
4126B	1½" stain. steel hopper saver, white silicone backing
4127	blue silicone manifold gasket (food grade)
4137	white silicone manifold gasket (food grade)
5050	20" stainless-steel, 3 disk fluidizer plate (16" ID)
5052	20" carbon steel, 3 disk fluidizer plate (16" ID)
5012	20" neoprene gasket
4121	manifold, 1 port grey
4122	manifold, 2 port grey
4123	manifold, 3 port grey
4621	manifold, 1 port clear
4622	manifold, 2 port clear
4623	manifold, 3 port clear
4129	tee handle assembly - stainless-steel
4130	raised tee handle assembly
4139	hex bolt assembly - stainless-steel
4149	internal hex bolt assembly - stainless-steel
4159	bolt assembly T.I.R. stainless-steel
4111	1¾" hopper plug with gasket
4167	1½" hopper plug with gasket

# Tube Doors

## Hose Tube Doors

<b>Application:</b>	When not in use fuel delivery hoses are often stored in tubes that run the length of the tanker. A welded cap on one end and a hinged tube door welded on the other end keep the hoses in the storage tubes.
<b>Standards:</b>	Manufactured to weld to 6", 7" or 8" hose tubes.
<b>Materials:</b>	Aluminum body, Buna seals, stainless-steel door closure spring and hardware, nylon bushings
<b>Features &amp; Benefits:</b>	<ul style="list-style-type: none"> <li>• Pad-lockable</li> <li>• Keeps fuel delivery hoses neatly and safely stored in the designated storage tubes</li> <li>• Protects expensive delivery hoses and fittings from road dirt, salt and other environmental factors</li> </ul>



TDF6



TDF7



TDF8

Part #	Description
<b>TDF6</b>	6" hose tube door
<b>TDF7</b>	7" hose tube door
<b>TDF8</b>	8" hose tube door

## Air Relief Valve Testing Equipment

<b>Application:</b>	<p>In order to properly test air relief valves, enough air volume (SCFM) needs to be available directly to the air relief valve, or early blow offs will be falsely observed. The air relief starts to open slightly before the set pressure, and if there is not enough air volume to fully open the valve the tester may mistakenly take this to be an early blow off.</p> <p>Dixon® developed two pieces of equipment designed to provide enough air volume to properly test the valves:</p> <ul style="list-style-type: none"> <li>• DB9000 - with its own 20 gallon air tank which can be charged from most air compressors</li> <li>• DB9001 - mounted directly to a blower</li> </ul>
<b>Standards:</b>	<ul style="list-style-type: none"> <li>• ASME approved pressure vessel (DB9000)</li> <li>• Use shop air supply to test Dixon Bayco air relief valves</li> <li>• ASME approved 20 gallon tank with safety pop off</li> <li>• High flow pressure regulator</li> </ul>
<b>Material:</b>	Mainly steel construction
<b>Features &amp; Benefits:</b>	<ul style="list-style-type: none"> <li>• Allows fleets to properly and safely test air relief valves</li> <li>• Provided with a test platform to safely hold the air relief valve in the test stand allowing for the safe disassembly and reassembly of valves for internal inspection, cleaning and repair</li> </ul>

### Stationary Air Relief Tester

Part #
<b>DB9000</b>



# TTMA Reducing Flange Adapters

Application:	Used in applications where 3" and 4" TTMA flanges need to be connected.
Standards:	Flange connections are manufactured to connect with the TTMA (Tank Truck Manufacturers Association) flange pattern, see page 9 flange dimensions.
Material:	Aluminum
Features & Benefits:	<ul style="list-style-type: none"> <li>• Both sides machined to create smooth gasket sealing surfaces</li> <li>• 3/4" thick</li> <li>• 4" TTMA hole pattern sized for (8) 3/8" socket head cap screws</li> <li>• 3" TTMA hole pattern is blind threaded with 3/8"-16 thread to a depth of 9/16", supplied with (8) 3/8"-16 x 1" socket head cap screws</li> <li>• Easily connects with any item that has a 3" or 4" TTMA flange</li> </ul>



4443

Part #	Description
<b>4443</b>	4" TTMA x 3" TTMA reducer flange

See page 9 for TTMA flange gaskets.

## TTMA Weldable Flanges

Application:	Used in applications where a device such as a valve or sight flow with a TTMA flange needs to be connected to a pipe; the TTMA weldable flange is welded to the pipe and the desired device is bolted on.
Standards:	Flange connections are manufactured to connect with the TTMA (Tank Truck Manufacturers Association) flange pattern, see page 9 for flange dimensions.
Material:	Aluminum
Features & Benefits:	<ul style="list-style-type: none"> <li>• Butt weld version: the ID on side A is beveled to aid with butt welding., the flange face of side B is machined to create an even surface for the gasket seal.</li> <li>• Socket weld version: the ID on side A has a machined socket to allow the pipe to slide in to be socket welded</li> <li>• Flange face of side B is machined to create an even surface for the gasket seal.</li> <li>• Flanges are 3/8" thick</li> <li>• Easily connect with any item that has a 3" or 4" TTMA flange</li> </ul>



TTF3AL



TTF400SP

Part #	Description
<b>TTF3AL</b>	3" TTMA butt weld on flange
<b>TTF4AL</b>	4" TTMA butt weld on flange
<b>TTF400SP</b>	4" TTMA socket weld on flange

• See page 9 for TTMA flange gaskets.

# Cam & Groove Couplings x TTMA Flange

<b>Application:</b>	Used to connect dry bulk product hoses; the TTMA flange x cam and groove allows product hoses to be connected directly to the dry bulk tanker piping system.
<b>Standards:</b>	Interchanges with all product produced to commercial item description A-A-59326B. Flange connections are manufactured to connect with the TTMA (Tank Truck Manufacturers Association) flange pattern, see page 9 for flange dimensions.
<b>Materials:</b>	Aluminum, Buna cam and groove gaskets
<b>Features &amp; Benefits:</b>	<ul style="list-style-type: none"> <li>• Precision machined to rigid tolerances</li> <li>• Durable stainless-steel cam arm pins will not rust or bind, for greater strength and safety</li> <li>• Recess holds gasket firmly in place - ensures proper placement</li> </ul>



300-ALT-AL



300-DLT-AL



40022ALTAL



40022DLTAL

Part #	Description
<b>300-ALT-AL</b> <sup>1</sup>	3" cam and groove adapter (straight) x 3" TTMA flange
<b>3040ALTAL</b>	4" cam and groove adapter (straight) x 3" TTMA flange
<b>400-ALT-AL</b> <sup>1</sup>	4" cam and groove adapter (straight) x 4" TTMA flange
<b>40022ALTAL</b>	4" cam and groove adapter (22½°) x 4" TTMA flange
<b>600-ALT-AL</b>	6" cam and groove adapter (straight) x 6" TTMA flange
<b>300-DLT-AL</b>	3" cam and groove coupler (straight) x 3" TTMA flange
<b>3040DLTAL</b>	4" cam and groove coupler (straight) x 3" TTMA flange
<b>400-DLT-AL</b>	4" cam and groove coupler (straight) x 4" TTMA flange
<b>40022DLTAL</b>	4" cam and groove coupler (22½°) x 4" TTMA flange
<b>600-DLT-AL</b>	6" cam and groove coupler (straight) x 6" TTMA flange

<sup>1</sup> 300-ALT-AL and 400-ALT-AL are also available in 316 stainless-steel

• See page 9 for TTMA flange gaskets.

# Cam & Groove with Straight Thread (NPSM)

Dry Bulk Products

Application:	Used to connect dry bulk product hoses. Standard threaded cam and groove fittings have a tapered thread, which when threaded to another tapered thread, leaves exposed thread within the product flow path. The cavity left by the exposed thread not only causes product turbulence, but it also is a place where product can build up. When the Dixon® cam and groove with female straight threads is threaded onto a male tapered thread (NPT), the male tapered thread threads all the way to the bottom of the thread cavity, creating a smooth product path. This reduces product turbulence and build-up.
Standards:	Interchanges with all product produced to commercial item description A-A-59326B. Threads are machined to the NPSM standard.
Materials:	Aluminum, cork/Buna adapter gasket, Buna coupler gasket
Features & Benefits:	<ul style="list-style-type: none"> <li>• No exposed threads within the product flow, reduces product turbulence and product build up</li> <li>• Precision machined to rigid tolerances</li> <li>• Durable stainless-steel cam arm pins will not rust or bind, for greater strength and safety</li> <li>• Recess holds coupler gasket firmly in place - ensures proper placement</li> </ul>



400-AS-AL



ADS400

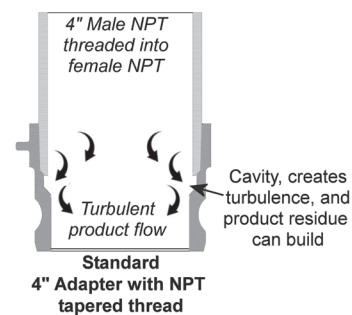
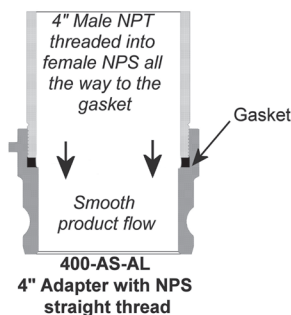

Part #	Description
<b>400-AS-AL</b>	4" cam and groove adapter with female NPSM (straight thread)
<b>400GAGFI</b>	replacement cork/Buna thread gasket for 400-AS-AL
<b>ADS400</b>	4" cam and groove coupler with female NPSM (straight thread)
<b>400-G-BU</b> <sup>1</sup>	replacement Buna coupler gasket for ADS400

<sup>1</sup> Other material coupler gaskets are available, please contact Dixon®.

• Please contact Dixon® for other materials and configurations.

# Products for Blowers

## 2182 Blower 2" Air Relief Valves

### Bill of Materials

Item #	Description	Qty
1	vent cowl	1
2	top body	1
3	valve seat	1
4	diaphragm	1
5	spring	1
6	lock washer	4
7	valve plate	1
8	spacer	---
9	cup seal	1
10	cap	1
11	body bolt	4

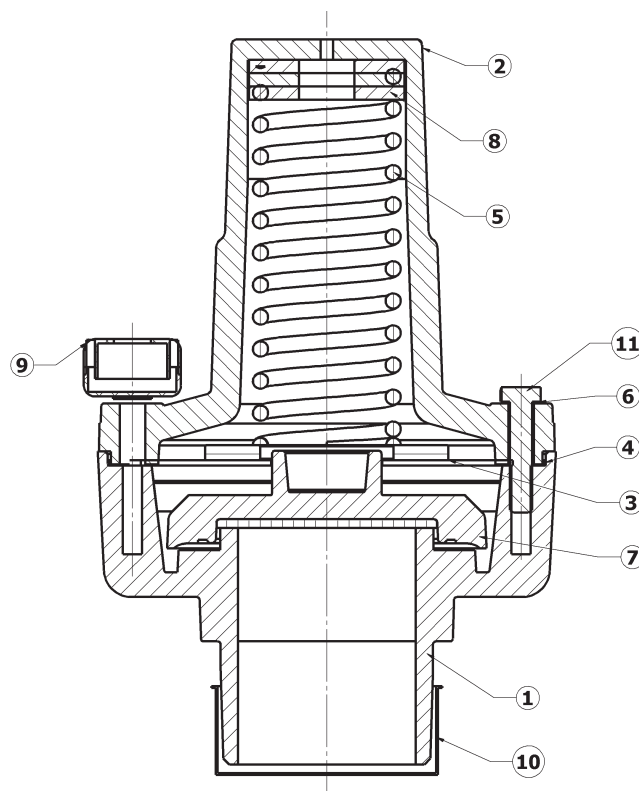

### Repair Kits

Part #	Description	Includes Item #
<b>2182RK15</b>	2182 repair kit, <b>15 PSI</b> spring (+2/-0 PSI tolerance), spring seat, diaphragm, valve plate, bolts, lockwashers, tamper proof seal and valve label	3, 4, 5, 6, 8, 9, 10
<b>2182RK18</b>	2180/18 repair kit, <b>18 PSI</b> spring (+2/-0 PSI tolerance), spring seat, diaphragm, valve plate, bolts, lockwashers, tamper proof seal and valve label	3, 4, 5, 6, 8, 9, 10



Disassembly, tampering or modifications will void the product warranty and could result in personal injury or death and extensive property damage.

Dry Bulk  
Products

Dry Bulk  
Replacement Parts

# Products for Blowers

## High Flow Blower Swing Check Manifold Valves 3090 Series TTMA Flange x Adapter

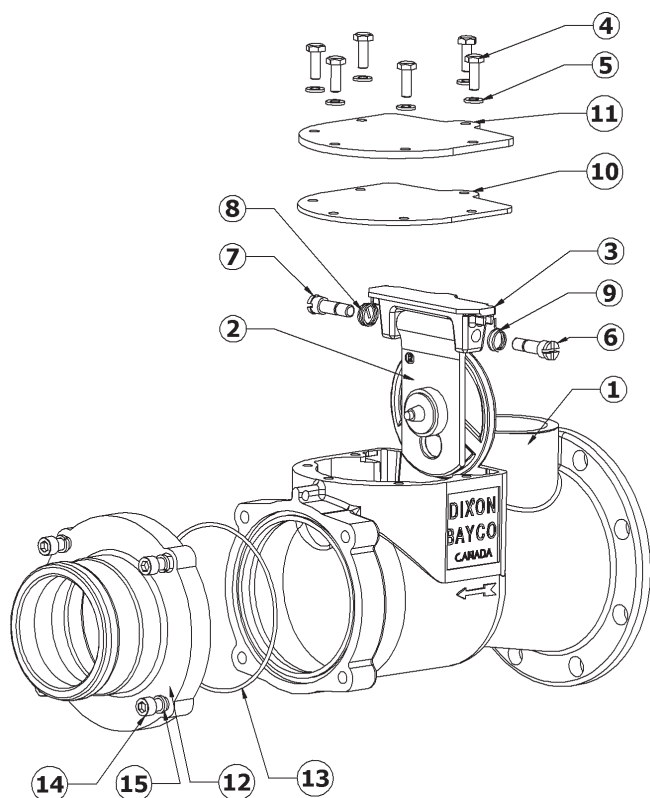

### Bill of Materials

Item #	Description	Part No.	Qty
1	swing check manifold body	---	1
2A	valve flapper assembly silicone seal (3090M, 3090MA, 3090MB and 3090F)	use kit <b>3090RK2</b>	1
2B	valve flapper assembly metal seal (3091MA)	use kit <b>3091RK2</b>	1
3	flapper valve yoke	<b>341595</b>	1
4	bolt	use kit <b>3030HK</b>	6
5	lock washer	use kit <b>3030HK</b>	6
6	left hand shaft	<b>390799</b>	1
7	right hand shaft	<b>390798</b>	1
8	right hand spring	use kit <b>3030RK3</b>	1
9	left hand spring	use kit <b>3030RK3</b>	1
10	cover gasket silicone	<b>112257</b>	1
11	cover	<b>341611</b>	1
12A	3" adapter outlet (for 3090MA, 3090MAS and 3091MA, includes items 14 and 15)	<b>6000-16</b>	1
12B	4" adapter outlet (for 3090MB, and 3090MBS, includes items 14 and 15)	<b>6000-17</b>	1
12C	4" FNPT outlet (for 3090F)	<b>6000-20</b>	1
13	adapter outlet O-ring	<b>3090RK1</b>	1
14	adapter outlet hex bolt	use kit <b>6000NPHK</b>	4
15	adapter outlet lock washer	use kit <b>6000NPHK</b>	4

### Repair Kits

Part #	Description	Includes Item #
<b>3090RK1</b>	adapter outlet O-ring	13
<b>3091RK2</b>	replacement metal seal flapper kit, flapper assembly, yoke, springs, shafts, cover gasket (for 3091MA)	2B, 3, 6, 7, 8, 9, 10
<b>3090RK2</b>	complete rebuild kit, silicone flapper assembly, yoke, springs, shafts, cover gasket, bolts and lock washers (for 3090M, 3090MA, 3090MB and 3090F)	2A, 3, 4, 5, 6, 7, 8, 9, 10
<b>3091RK1</b>	complete rebuild kit, metal seat flapper assembly, yoke, springs, shafts, cover gasket, bolts and lock washers (for 3091MA)	2B, 3, 4, 5, 6, 7, 8, 9, 10
<b>3030HK</b>	replacement cover bolts and lock washers	4, 5
<b>3030RK3</b>	replacement left and right springs	8, 9
<b>6000NPHK</b>	outlet bolts and lock washers	14, 15

Dry Bulk Replacement Parts

# Products for Blowers

## 2180 Series 2" Air Relief Valves models 2180 and A2180

### Bill of Materials

Item #	Description	Qty
1	vent cowl	1
2	top body	1
3	valve	1
4	spring	1
5	valve seat	1
6	diaphragm	1
7	spacers	---
8	body bolt	4
9	body bolt washer	4
10	cup seal	1
11	plug	1

- Only **15 PSI** and **18 PSI** repair kits are available (below), all valves of other pressure settings must be returned to Dixon® for rebuilding.

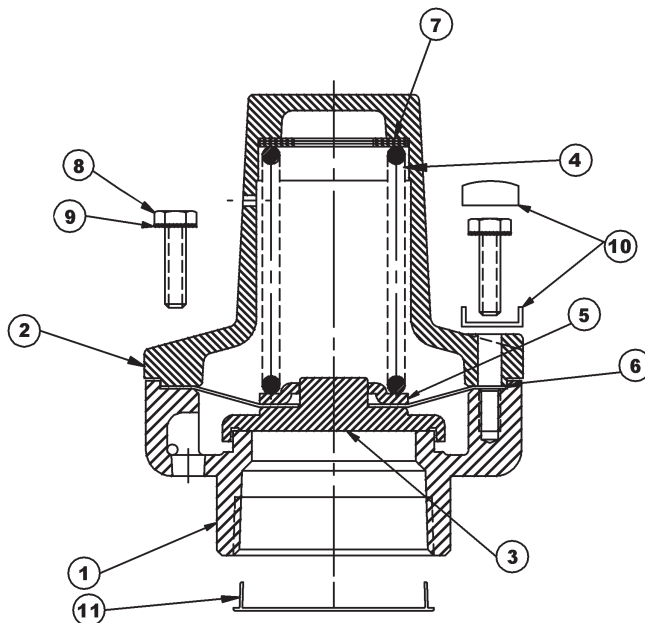

The detailed instructions enclosed with each repair kit must be followed. Failure to comply with these instructions including disassembly, tampering or modifications using processes and parts not described in these instructions or supplied with this rebuild kit will void the product warranty and could result in personal injury or death and extensive property damage.



### Repair Kits

Part #	Description	Includes Item #
<b>2180RK15</b>	2182 repair kit, <b>15 PSI</b> spring (+2/-0 PSI tolerance), spring seat, diaphragm, valve plate, bolts, lockwashers, tamper proof seal and valve label	3, 4, 5, 6, 8, 9, 10
<b>2180RK18</b>	2180/18 repair kit, <b>18 PSI</b> spring (+2/-0 PSI tolerance), spring seat, diaphragm, valve plate, bolts, lockwashers, tamper proof seal and valve label	3, 4, 5, 6, 8, 9, 10

Repair kits fit the 2180 series (non adjustable) relief valves with female NPT, grooved and cam and groove adapter ends (not for use in the adjustable 2180 series).

## 3180 Series 3" Air Relief Valves

### Bill of Materials

Item #	Description	Qty
1	bottom cowl	1
2	cover	1
3	spring seat	1
4	spring	1
5	set washer	1
6	hex screw	2
7	drilled screw	2
8	lock washer	4
9	cup seal	1
10	plug	1
11	valve sub-assembly	1

- Repair kits are not available. All 3180 and A3180 relief valves must be returned to Dixon® for rebuilding.
- Disassembly, tampering or modifications will void the product warranty and could result in personal injury

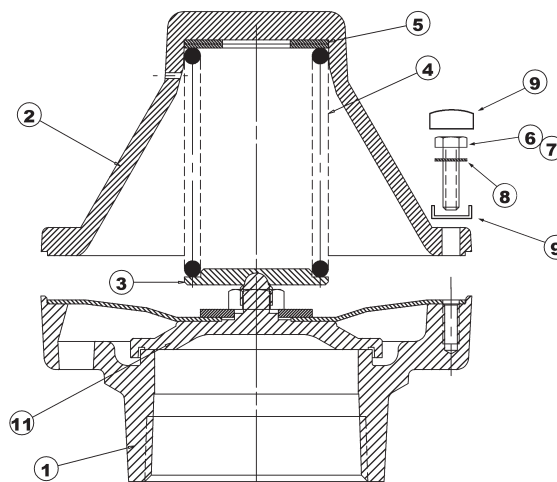

Replacement Parts  
Dry Bulk

# Products for Blowers

## 2" and 3" Adjustable Air Relief Valves models A2180ADJ and A3180ADJ

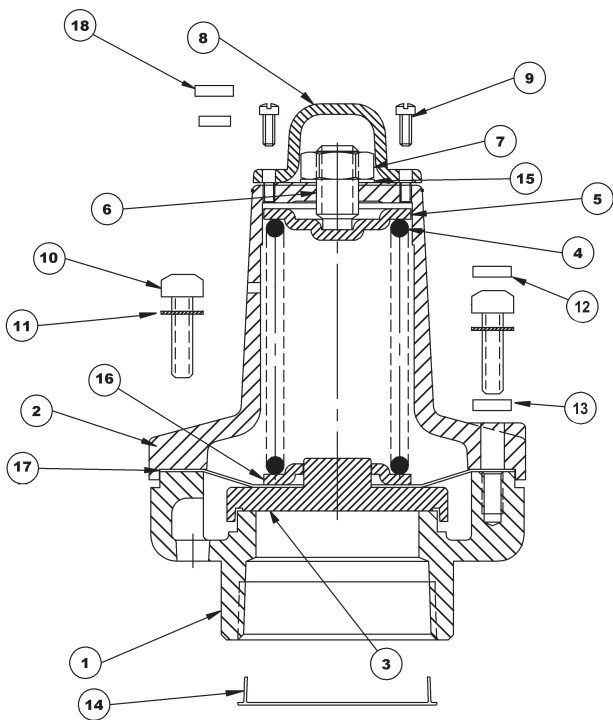

### Bill of Materials

Item #	Description	Qty
1	vent cowl	1
2	top body	1
3	valve	1
4	spring	1
5	spring plate	1
6	adjustable screw	1
7	lock nut	1
8	adjustment cap	1
9	cap screw	2
10	body screw	4
11	body screw lock washer	4
12	cup seal top	1
13	cup seal bottom	1
14	plug	1
15	lock washer	1
16	spring seat	1
17	diaphragm	1
18	cap screw cup seal	1

- Repair kits are not available. All adjustable relief valves must be returned to Dixon® for rebuilding.
- Disassembly, tampering or modifications will void the product warranty and could result in personal injury or death and extensive property damage. 

## 1120 Series 1½" Vacuum Relief Valves

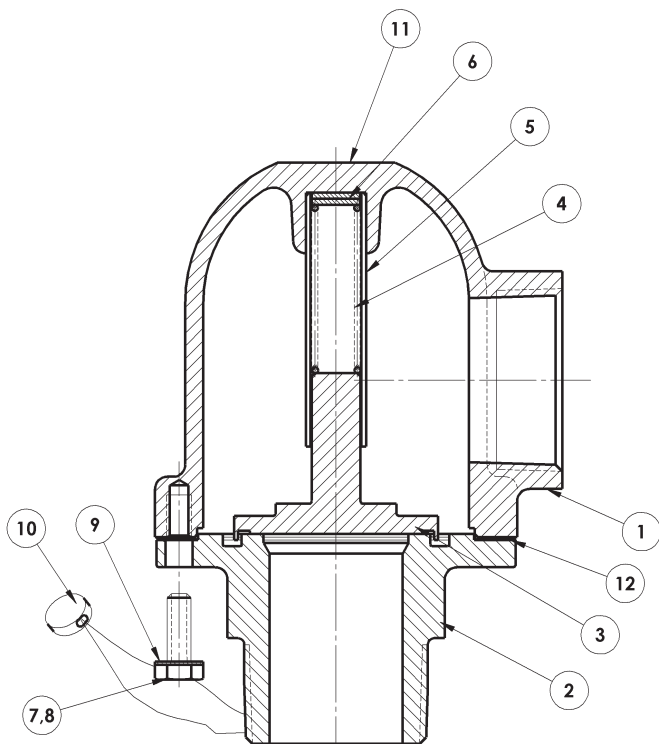

### Bill of Materials

Item #	Description	Qty
1	cover	1
2	bottom	1
3	valve	1
4	spring	1
5	stem guide	1
6	spacer	2
7	drilled screw	2
8	screw	2
9	lock washer	4
10	cup seal	1
11	label	1
12	gasket	1

- Repair kits are not available. All 1120 relief valves must be returned to Dixon® for rebuilding.
- Disassembly, tampering or modifications will void the product warranty and could result in personal injury or death and extensive property damage. 

Dry Bulk Replacement Parts

# Trailer/Tank Mounted Air Relief Valves

## 2120 Series 2" Vacuum Relief Valves

### Bill of Materials

Item #	Description	Qty
1	cover	1
2	bottom	1
3	valve	1
4	valve stem	1
5	valve guide	1
6	spring	1
7	set washer	2
8	drilled screw	2
9	screw	2
10	lock washer	4
11	cup seal	1
12	label	1
13	thread plug	1
14	gasket	1

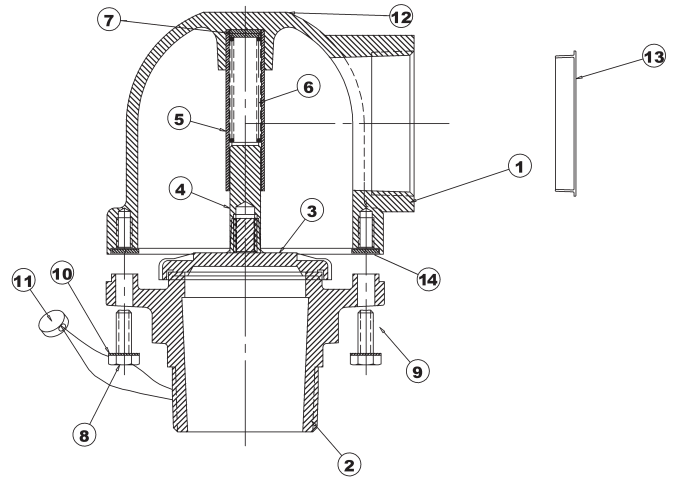

- Repair kits are not available. All 2120 relief valves must be returned to Dixon® for rebuilding.
- Disassembly, tampering or modifications will void the product warranty and could result in personal injury or death and extensive property damage.



## 3120 Series 3" Vacuum Relief Valves

### Bill of Materials

Item #	Description	Qty
1	top cover	1
2	bottom body	1
3	valve	1
4	valve stem	1
5	stem guide	1
6	spring	1
7	set washer	3
8	screw	4
9	drilled screw	2
10	lock washer	6
11	cup seal	1
12	thread plug	2
13	gasket	1

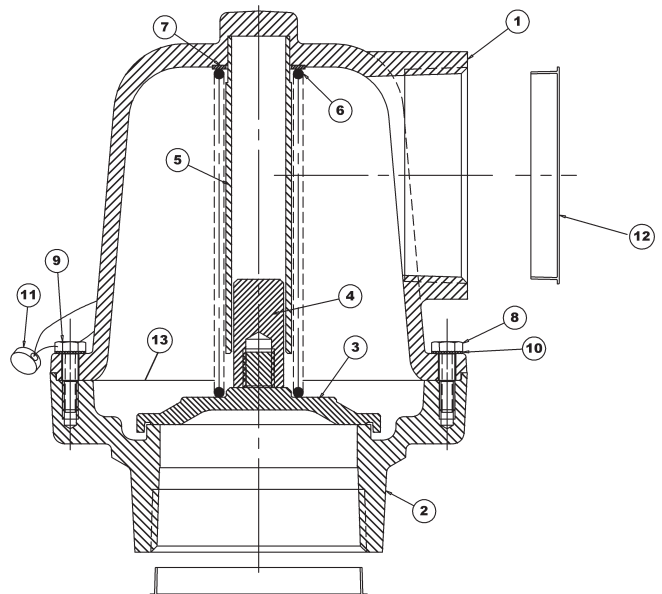

- Repair kits are not available. All 3120 relief valves must be returned to Dixon® for rebuilding.
- Disassembly, tampering or modifications will void the product warranty and could result in personal injury or death and extensive property damage.



Dry Bulk  
Replacement Parts

# Cam & Groove In-Line Sight Glass

## Replacement Parts

3544CA 3543CA 3534CA 3533CA 3544CC 3543CC 3533CC 3544AA 3534AA 3533AA

Part #	Description	3544CA	3543CA	3534CA	3533CA	3544CC	3543CC	3533CC	3544AA	3534AA	3533AA
6000-24	3" adapter end	N/A	1	N/A	1	N/A	N/A	N/A	N/A	N/A	1
341351	3" adapter end with threaded bolt holes	N/A	N/A	N/A	N/A	N/A	N/A	N/A	N/A	1	1
6000-18	4" adapter end	1	N/A	1	N/A	N/A	N/A	N/A	2	1	N/A
6000-23	3" coupler end	N/A	N/A	1	1	N/A	1	2	N/A	N/A	N/A
6000-19	4" coupler end	1	1	N/A	N/A	2	1	N/A	N/A	N/A	N/A
6400SGK	replacement sight glass kit (2 Buna O-rings and acrylic sight glass)	1	1	1	1	1	1	1	1	1	1
6544CA-1	sight glass spacers	4	4	4	4	4	4	4	4	4	4
AS156	Buna O-ring for sight glass	2	2	2	2	2	2	2	2	2	2
SC5-16-18X2.5P	bolts 5/16" x 2 1/2"	N/A	N/A	N/A	N/A	N/A	N/A	N/A	4	4	4
SC5-16-18X2.75P	bolts 5/16" x 2 3/4"	4	4	4	4	4	4	4	N/A	N/A	N/A
110978	hex nut 5/16"	4	4	4	4	4	4	4	N/A	N/A	N/A
111430	helicoil nut 5/16"	N/A	N/A	N/A	N/A	N/A	N/A	N/A	4	N/A	N/A
110977	lock washer (for nut end of bolt)	4	4	4	4	4	4	4	N/A	N/A	N/A

## Swing Check Valves

### Bayco Classic 3000 Series 3" Swing Check Valves 3000 Threaded and 3001 Square Flange Units

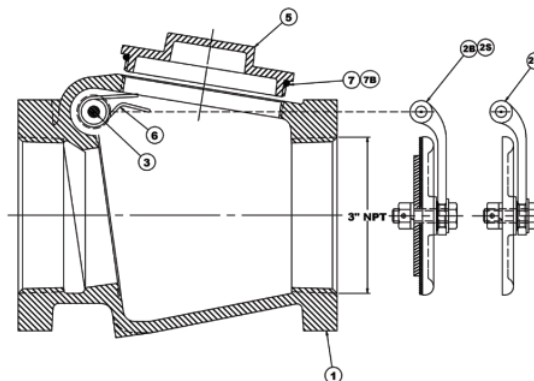
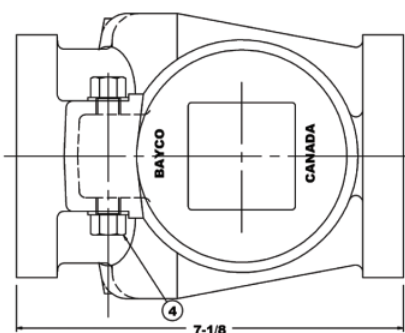

#### Bill of Materials

Item #	Description	Part #	Qty
1	swing check body	---	1
2M	valve flapper assembly with metal seal	use kit <b>300-SPK</b>	1
2B	valve flapper assembly with Buna seal	use kit <b>300-BSPK</b>	1
2S	valve flapper assembly with silicone seal	use kit <b>300-SSPK</b>	1
3	shaft	<b>3000-4</b>	1
4	shaft nut	<b>3000-5</b>	2
5	clean out cap	<b>341131</b>	1
6	spring (for units with spring return flapper)	<b>SPRG/L4603</b>	1
7	clean out cap O-ring seal	<b>O-RINGAS238</b>	1
7B	clean out cap O-ring silicone	<b>112254</b>	1

#### Repair Kits

Part #	Description	Includes Item #
<b>300-SSPK</b>	silicone seal flapper assembly, shaft, nuts, flapper spring and clean out cap O-ring seal	2S, 3, 4, 6, 7B
<b>300-SK</b>	silicone seal flapper assembly, shaft, nuts and clean out cap O-ring seal	2S, 3, 4, 7B
<b>300-BSPK</b>	Buna seal flapper assembly, shaft, nuts, flapper spring and clean out cap O-ring seal	2B, 3, 4, 6, 7B
<b>300-BK</b>	Buna seal flapper assembly, shaft, nuts and clean out cap O-ring seal	2B, 3, 4, 7B

Dry Bulk Replacement Parts

# Swing Check Valves

## Bayco Classic 3000 Series 3" Swing Check Valves 3000 Round Flange Units

### Bill of Materials

Item #	Description	Part #	Qty
1	swing check body	---	1
2M	valve flapper assembly with metal seal	use kit <b>300-SPK</b>	1
2B	valve flapper assembly with Buna seal	use kit <b>300-BSPK</b>	1
2S	valve flapper assembly with silicone seal	use kit <b>300-SSPK</b>	1
3	shaft	<b>3000-4</b>	1
4	shaft nut	<b>3000-5</b>	2
5	clean out cap	<b>3000CAP</b>	1
6	spring (for units with spring return flapper)	<b>SPRG/L4603</b>	1

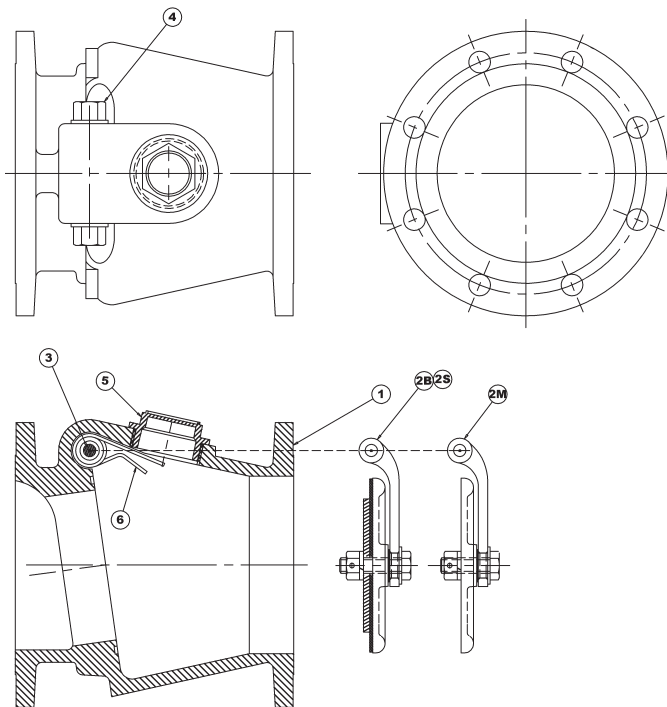

### Repair Kits

Part #	Description	Includes Item #
<b>300-SSPK</b>	silicone seal flapper assembly, shaft, nuts, flapper spring	2S, 3, 4, 6
<b>300-SK</b>	silicone seal flapper assembly, shaft, nuts	2S, 3, 4
<b>300-BSPK</b>	Buna seal flapper assembly, shaft, nuts, flapper spring	2B, 3, 4, 6
<b>300-BK</b>	Buna seal flapper assembly, shaft, nuts	2B, 3, 4
<b>300-SPK</b>	metal seal flapper assembly, shaft, nuts, flapper spring	2M, 3, 4, 6
<b>300-K</b>	metal seal flapper assembly, shaft, nuts	2M, 3, 4

## Bayco High Flow 3020 Series 2" Swing Check Valves

### Bill of Materials

Item #	Description	Part #	Qty
1	swing check body	---	1
2	valve flapper assembly, white EPDM	use kit <b>3020-FA</b>	1
3	shaft	<b>390777</b>	1
4	cover plate & retaining ring	use kit <b>3020-CS</b>	1
5	shaft bearing	<b>111321</b>	2
6	right spring	<b>111324</b>	1
7	left spring	<b>111325</b>	1
8	cover O-ring	<b>111326</b>	1
9	cap	<b>3020-C</b>	1
10	threaded shaft plug	<b>111443</b>	2
11	shaft bushing	<b>390784</b>	2
**	flange close clearance nuts (2 provided with 3020SQ, due to close clearance between flange and body)	<b>111485</b>	2

\*\* not illustrated

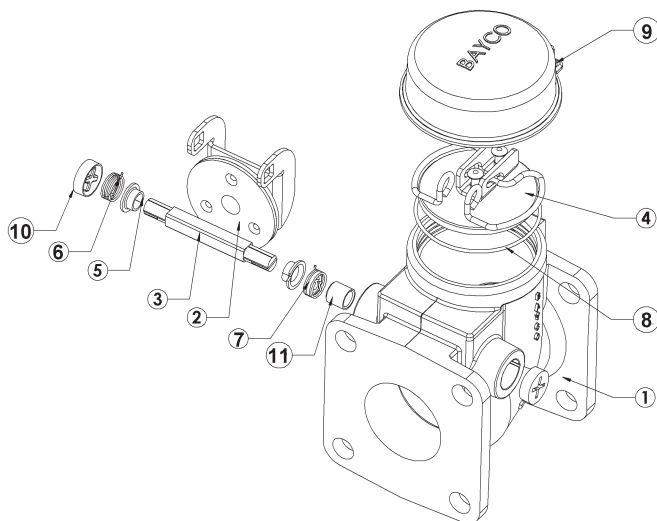

### Repair Kits

Part #	Description	Includes Item #
<b>3020-CS</b>	top cover plate kit, cover plate, spring clip assembly and O-ring seal	4, 8
	replacement white EPDM flapper kit, flapper assembly, shaft, shaft bearings, springs and	

Replacement Parts

Dry Bulk

# Swing Check Valves

## Bayco High Flow 3030 Series 3" Swing Check Valves Round Flange, Square Flange, Threaded and Grooved Ends

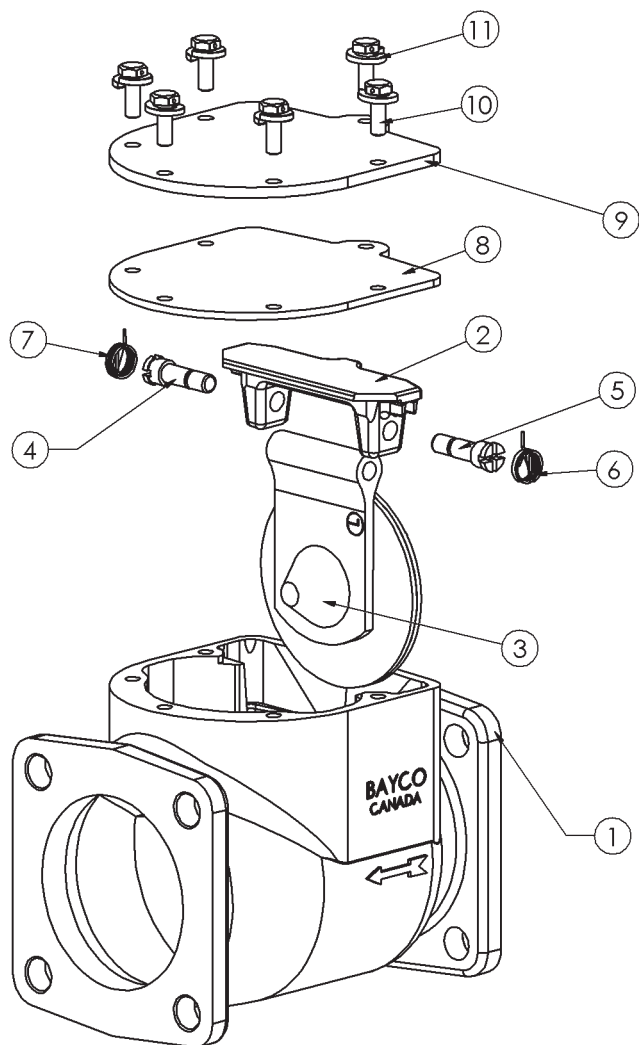

### Bill of Materials

Item #	Description	Part #	Qty
1	swing check body	---	1
2	flapper valve yoke	<b>341595</b>	1
3	valve flapper assembly with metal seal	use kit <b>3091RK1</b>	1
4	right hand shaft	<b>390798</b>	1
5	left hand shaft	<b>390799</b>	1
6	left hand spring	use kit <b>3030RK3</b>	1
7	right hand spring	use kit <b>3030RK3</b>	1
8	cover gasket silicone	<b>112257</b>	1
9	cover	<b>341611</b>	1
10	bolt	use kit <b>3030HK</b>	6
11	lock washer	use kit <b>3030HK</b>	6

Dry Bulk  
Replacement Parts

### Repair Kits

Part #	Description	Includes Item #
<b>3090RK2</b>	complete rebuild kit, silicone flapper assembly, yoke, springs, shafts, cover gasket, bolts and lock washers (for 3030RD-SSP, 3030SQ-SSP, 3030TE-SSP and 3030VIC-SSP)	2, 3A, 4, 5, 6, 7, 8, 10, 11
<b>3091RK1</b>	complete rebuild kit, metal seal flapper assembly, yoke, springs, shafts, cover gasket, bolts and lockwashers (for 3031RD, 3031SQ, 3031TE and 3031VIC)	2, 3B, 4, 5, 6, 7, 8, 10, 11
<b>3030HK</b>	replacement bolts and lockwashers	10, 11
<b>3030RK3</b>	replacement left and right springs	6, 7

# Swing Check Valves

## Bayco High Flow 4040 Series 4" Swing Check Valves Round Flange and Threaded Units

### Bill of Materials

Item #	Description	Part #	Qty
1	swing check body	---	1
2A	valve flapper assembly white EPDM (4040RD and 4040TE)	use kit <b>4040RK1</b>	1
3	flapper valve yoke	<b>341595</b>	1
4A	left hand shaft (4040RD and 4040TE)	<b>390799</b>	1
4B	left hand shaft (4041RD, 4042RD, 4041TE, 4042TE)	<b>390846</b>	1
5A	left hand spring (4040RD and 4040TE)	use kit <b>3030RK3</b>	1
5B	left hand spring (4041RD, 4042RD, 4041TE and 4042TE)	use kit <b>4041RK3</b>	1
6A	right hand shaft (4040RD and 4040TE)	<b>390798</b>	1
6B	right hand shaft (4041RD, 4042RD, 4041TE and 4042TE)	<b>390847</b>	1
7A	right hand spring (4040RD and 4040TE)	use kit <b>3030RK3</b>	1
7B	right hand spring (4041RD, 4042RD, 4041TE and 4042TE)	use kit <b>4041RK3</b>	1
8	cover gasket	<b>111215</b>	1
9	cover	<b>340039</b>	1
10	bolt	use kit <b>3030HK</b>	6
11	lock washer	use kit <b>3030HK</b>	6

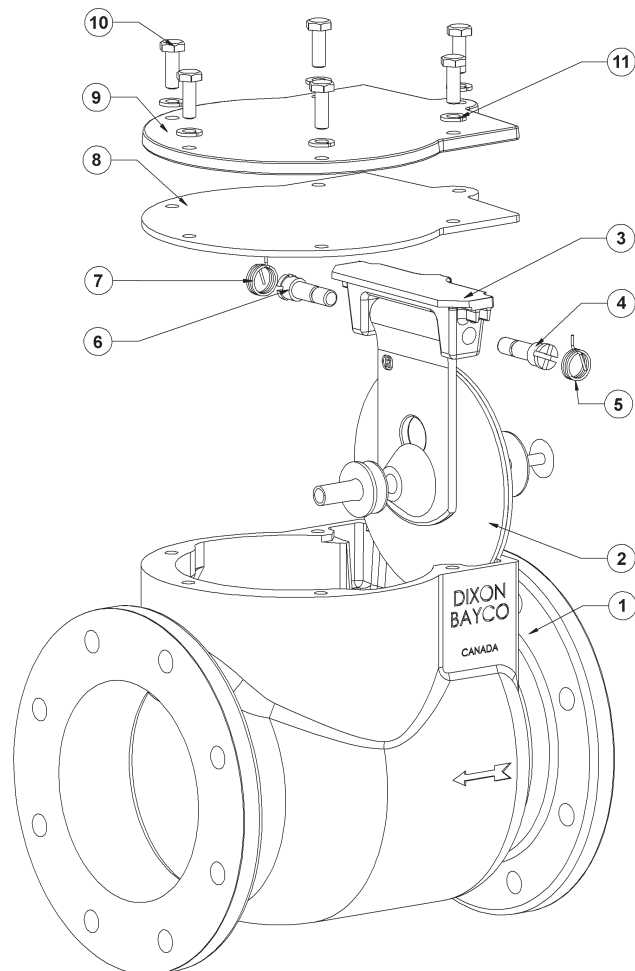

### Repair Kits

Part #	Description	Includes Item #
<b>4040RK1</b>	replacement white EPDM flapper kit, flapper assembly, yoke, springs, shafts, cover gasket (for 4040RD and 4040TE)	2A, 3, 4A, 5A, 6A, 7A, 8
<b>4041RK1</b> <sup>1</sup>	complete rebuild kit, metal seat flapper assembly, yoke, springs, shafts, cover gasket, bolts and lock washers (for 4041RD and 4041TE)	2B, 3, 4B, 5B, 6B, 7B, 8, 10, 11
<b>4042RK1</b> <sup>1</sup>	complete rebuild kit, red silicone flapper assembly, yoke, springs, shafts, cover gasket, bolts and lock washers (for 4042RD and 4042TE)	2C, 3, 4A, 5A, 6A, 7A, 8, 10, 11
<b>3030HK</b>	replacement bolts and lock washers	10, 11
<b>3030RK3</b>	replacement left and right springs (for 4040RD and 4040TE)	5A, 7A
<b>4041RK3</b>	replacement left and right springs (for 4041RD, 4041TE, 4042RD and 4042TE)	5B, 7B

<sup>1</sup> Kits 4041RK1 and 4042RK1 contain 2 sets of shafts and springs. Swing check valves manufactured after March 2007 should use the larger axial shafts and larger torsion springs. Swing check valves manufactured prior to March 2007 will require the use of the shorter axial shafts and the smaller torsion springs.

The smaller torsion springs will not return the flappers contained in the 4041RK1 and 4042RK1 kits to a fully closed position if the valve is mounted vertically or upside down. Ensure that these mounting positions are avoided if the smaller springs are used with the 4041RK1 and 4042RK1 kits.



# Clump Buster

## Clump Buster - DB1000

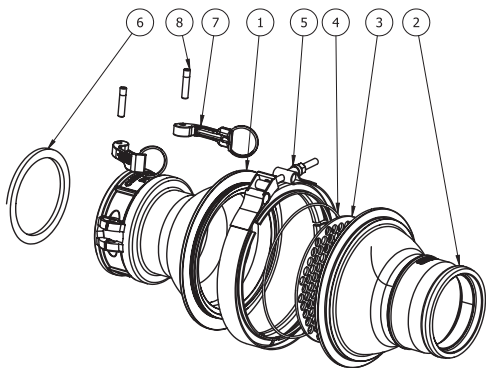
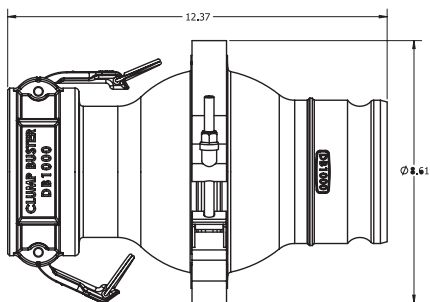

### Bill of Materials - DB1000

Item #	Description	Part #	Qty
1	coupler - machining	<b>341841</b>	1
2	adapter - machining	<b>341842</b>	1
3	screen	<b>391862</b>	1
4	O-ring 2-166	<b>112293</b>	1
5	clamp	<b>112291</b>	1
6	gasket 4"	<b>400-G-BU</b>	1
7	cam arm with ring	<b>300-HR-BR</b>	2
8	pin	<b>325-P</b>	2

## Clump Buster With Sight Glass - DB1000-SFI

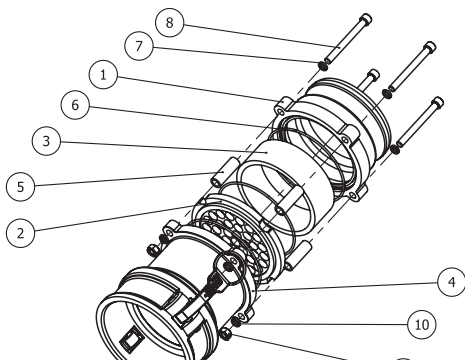
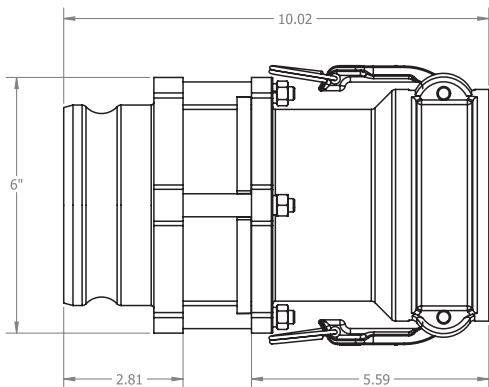

### Bill of Materials - DB1000SFI

Item #	Description	Part #	Qty
1	4" adapter for SG (AL)	<b>341228</b>	1
2	clump buster screen	<b>112295</b>	1
3	sight glass	<b>6000-10</b> (390114)	1
4	coupler assembly 4"	<b>6000-19</b>	1
5	spacer	<b>390911 spacer</b>	4
6	O-ring 3 3/4" x 0.093" Buna-N	<b>AS156</b> (110177)	3
7	lock washer	<b>111723</b>	4
8	screw socket head 0.3125-18NC x 3"	<b>112296</b>	4
9	nut	<b>110978</b>	4
10	lock washer	<b>110977</b>	4

Dry Bulk Replacement Parts

# Grooved Pipe Connections

## Aluminum Quick Connect Clamps

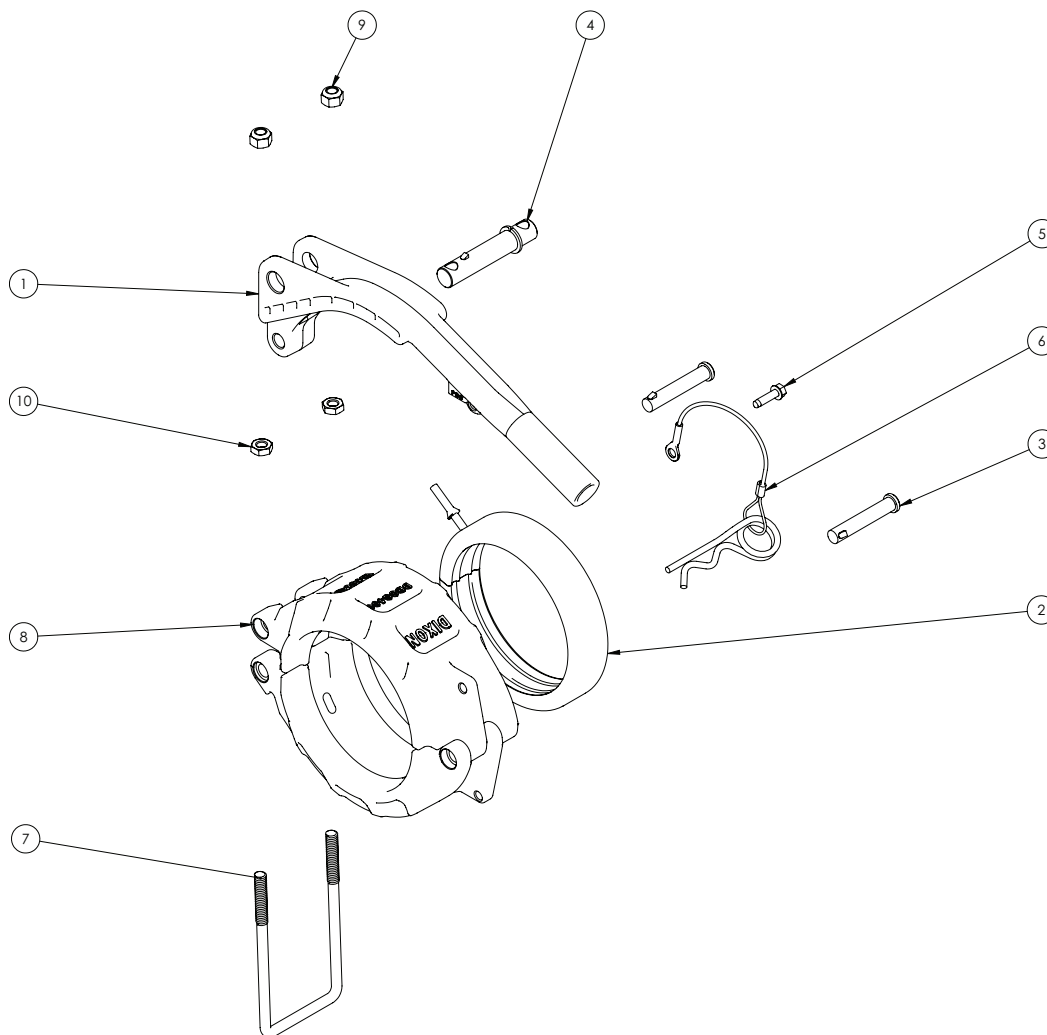

### Bill of Materials - DBCG400

Item #	Description	Part #	Material	Qty
1	4" pipe coupler handle	<b>40396NY</b>	nylon	1
2	4" pipe coupler split gasket	<b>40398BN</b>	Buna-N / EPDM	1
3	small quick assembly pin	<b>40431SS</b>	stainless-steel	2
4	large quick assembly pin	<b>40430SS</b>	stainless-steel	1
5	screw	<b>10765SS</b>	stainless-steel	1
6	lanyard and cotter pin assembly	<b>40432</b>	---	1
7	coupler, bail latch	<b>40429SS</b>	stainless-steel	1
8	4" pipe coupler half	<b>40397AL</b>	aluminum	2
9	5/16-18 nut, nylon insert	<b>40427SS</b>	stainless-steel	2
10	5/15-18 jam nut	<b>40428SS</b>	stainless-steel	2

Dry Bulk  
Replacement Parts

# Butterfly Valves

## Butterfly Valve Replacement Parts

Part #	Description
<b>2-400-422240</b>	replacement stainless-steel valve stem for 2" valve
<b>3-400-422240</b>	replacement stainless-steel valve stem for 3" valve
<b>4-400-422240</b>	replacement stainless-steel valve stem for 4" valve
<b>5-400-422240</b>	replacement stainless-steel valve stem for 5" valve
<b>6-400-422240</b>	replacement stainless-steel valve stem for 6" valve
<b>2-3-400-99BPKIT</b>	bushing and packing kit for 2" and 3" valves
<b>4-6-400-99BPKIT</b>	bushing and packing kit for 4", 5" and 6" valves (not for 6" 2-piece valve 6-390-828U501)
<b>6-99-400BPKIT</b>	bushing and packing kit for 6" (6-390-828U501)
<b>2-3-213</b>	stainless screw sets for 2" and 3" valves
<b>4-5-6-213</b>	stainless screw sets for 4", 5" and 6" valves

Complete Valve Part # <sup>1</sup>	Replacement Handle Kits		Replacement Disc		Replacement Seats	
	Aluminum Part #	Iron Part #	Iron Part #	Stainless Steel	Black Buna Seat Part #	White Buna Seat Part #
2-400-1500	<b>DB206-23-5</b>	<b>DB237-23-10</b>	<b>2-400-422237F</b>	---	<b>2-400-422500</b>	---
3-380-828501			---	---	---	<b>3-400-422501</b>
3-480-1500	<b>DB206-23-5</b>	<b>DB237-23-10</b>	<b>3-400-422237F</b>	---	<b>3-400-422500</b>	---
3-480-3501			<b>3-400-422209F</b>	---	<b>3-400-422501</b>	---
4-380-828U501	<b>DB206-46-5</b>	<b>DB237-46-10</b>	---	---	---	<b>4-400-422501</b>
4-480-1500	<b>DB206-46-5</b>	<b>DB237-46-10</b>	<b>4-400-422237U</b>	---	<b>4-400-422500</b>	---
4-480-3501	<b>DB206-23-5</b>	<b>DB237-23-10</b>	<b>4-400-422209U</b>	---	<b>4-400-422501</b>	---
4A-400-1500	<b>DB206-46-5</b>	<b>DB237-46-10</b>	<b>4A-400-422237U</b>	---	<b>4A-400-422500</b>	---
4A-400-3501			<b>4A-400-422209U</b>	---	<b>4A-400-422501</b>	---
4A-480-1500			<b>4A-400-422237U</b>	---	<b>4A-400-422500</b>	---
4A-480-3501			<b>4A-400-422209U</b>	---	<b>4A-400-422501</b>	---
5-380-828U501	<b>DB206-46-5</b>	<b>DB237-46-10</b>	---	---	---	<b>5-400-422501</b>
5-480-1500	<b>DB206-46-5</b>	<b>DB237-46-10</b>	<b>5-400-422237U</b>	---	<b>5-400-422500</b>	---
5-480-3501			<b>5-400-422209U</b>	---	<b>5-400-422501</b>	---
6-380-828U501	<b>DB400-206-65</b>	<b>DB400-237-610</b>	---	---	---	<b>6-390-393501</b>
6-400-3501	<b>DB206-46-5</b>	<b>DB237-46-10</b>	<b>6-400-422209U</b>	---	<b>6-400-422501</b>	---
6-480-1500			<b>6-400-422237U</b>	---	<b>6-400-422500</b>	---
6-480-3501			<b>6-400-422209U</b>	---	<b>6-400-422501</b>	---
8-400-1500	---	---	<b>8-400-4222370</b>	---	<b>8-400-422500</b>	---
10-400-1500	---	---	<b>10-400-4222370</b>	---	<b>10-400-422500</b>	---
DB3-400-1500	<b>DB206-23-5</b>	<b>DB237-23-10</b>	<b>112366</b>	---	<b>112363</b>	---
DB3-400-3501			---	<b>112365</b>	---	<b>112364</b>
DB4-400-1500	<b>DB206-46-5</b>	<b>DB237-46-10</b>	<b>112356</b>	---	<b>112354</b>	---
DB4-400-3501	<b>DB206-23-5</b>	<b>DB237-23-10</b>	---	<b>112357</b>	---	<b>112355</b>
DB5-400-1500	<b>DB206-46-5</b>	<b>DB237-46-10</b>	<b>112321R</b>	---	<b>112318</b>	---
DB5-400-3501			---	<b>112353</b>	---	<b>112352</b>

Dry Bulk Replacement Parts

<sup>1</sup> Handle kits are sold separately, choose aluminum or iron (2" thru 6" aluminum handles have 5 open positions, 8" and 10" aluminum and all iron handles have 10 open positions)

# Hopper Tees

## Bill of Materials - DB510TI / DB510TA / DB610TI

Item #	Description	Part #	Qty
1	grease fitting	40158ST	1
2	nut - ground bolt 1/2"-13	10224	3
3	5" bottom drop tee fitting door	40394AL	1
4	lockwasher	40263SS	2
5	bottom drop hopper tee clamp handle	40402SS	1
6	5" bottom drop hopper tee door insert	40403I	1
7	5 x 4 bottom drop hopper tee- xv		1
8	bottom drop hopper tee pivot/clamp rod	40436SS	3
9	1/2"-13 x 3 l hcsc	40443SS	1
10	bottom drop tee fitting handle cap	40444BR	1
11	e-clip 13.8mm x 5.84mm x .9mm	40442SS	1
12	1/2"-13 x 3 l hcsc	40437SS	2
13	1/2" washer (0.531 ID x 1.125 OD)	40440SS	2
14	1/2"-13 lock nut w/nylon insert	40435SS	2
15	5" bottom drop tee fitting door gasket	40441BN	1
16	3/8" washer (0.406 ID x 1.000 OD)	40438SS	2
17	3/8"-16 x 0.625l hcsc	40439SS	2
18	cotter pin 3/32 x 1 1/4"	40445SS	2
19	jam nut, 1/2"-13	40456SS	2
20	retain plate	40453SS	1
21	8-32 screw	40454SS	4
22	#8 split washer	40455SS	4

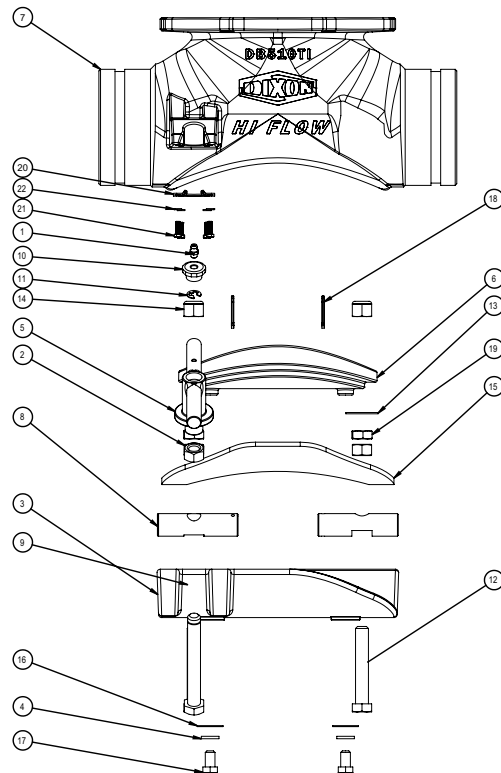

### Replacement Parts

Part #	Description
40394AL	5" drop tee fitting door
40436SS	bottom drop tee pivot/clamp rod

### Ultraflo Bottom Tee Replacement Parts

Part #	Description
4X4-BD-DOOR	4" bottom drop door only
8X4BD DOOR	8" bottom drop door only
4X4-BDGASKET	4" bottom drop door gasket only
6X4-BDGASKET	6" bottom drop door gasket only
8X4-BDGASKET	8" bottom drop door gasket only
4X4BDDOORASM	4" bottom drop door assembly with gasket
5X4-BDDOORASM	5" bottom drop door assembly with gasket
6X4-BDDOORASM	6" bottom drop door assembly with gasket
8X4-BDDOORASM	8" bottom drop door assembly with gasket
3/8T-BOLT	4" bottom drop door T-bolt
3/8INSERT	4" bottom drop door threaded insert for T-bolt
BDBOLTS	5", 6" and 8" bottom drop door bolt
GASKETRETAINER	gasket retainer - all sizes
3/8RETAINBOLT	3/8" gasket retainer bolt and lock nut - all sizes
5-RF	retention flange for low profile tees

Dry Bulk  
Replacement Parts

Part #	Page #	Part #	Page #	Part #	Page #
10-400-1500.....	16	2180/xx .....	4	300GDBSQK.....	9
10-400-4222370.....	36	2180B/15.....	4	300GTTFCB.....	9
10-400-422500.....	36	2180RK15.....	27	300GTTFK.....	9
10224.....	37	2180RK18.....	27	300GTTFTK.....	9
10765SS.....	35	2180V/15.....	4	3020-C.....	31
110977.....	30, 34	2182.....	6	3020-CS.....	31
110978.....	30, 34	2182/xx.....	3	3020-FA.....	31
111111.....	20	2182F/xx.....	3	3020SQ.....	10
111131.....	20	2182RK15.....	25	3020TE.....	10
111141.....	20	2182RK18.....	25	3030HK.....	26, 32, 33
111161.....	20	3-380-828501.....	17	3030RD-SSP.....	10
111215.....	33	3-400-422209F.....	36	3030RK3.....	26, 32, 33
111321.....	31	3-400-422237F.....	36	3030SQ-SSP.....	10
111324.....	31	3-400-422240.....	36	3030TE-SSP.....	10
111325.....	31	3-400-422500.....	36	3030VIC-SSP.....	10
111326.....	31	3-400-422501.....	36	3031RD.....	10
111430.....	30	3/8INSERT.....	37	3031SQ.....	10
111443.....	31	3/8RETAINBOLT.....	37	3031TE.....	10
111485.....	31	3/8T-BOLT.....	37	3031VIC.....	10
111723.....	34	300-ALT-AL.....	23	3040ALTAL.....	23
1120.....	6	300-BK.....	30, 31	3040DLTAL.....	23
1120/xx.....	6	300-BSPK.....	30, 31	3090F.....	8
112254.....	30	300-DLT-AL.....	23	3090M.....	8
112257.....	26, 32	300-HR-BR.....	34	3090MA.....	8
112291.....	34	300-K.....	30, 31	3090MA-DC.....	8
112293.....	34	300-SK.....	30, 31	3090MADC-82/18.....	8
112295.....	34	300-SPK.....	30, 31	3090MADC-82/18A.....	8
112296.....	34	300-SSPK.....	30, 31	3090MADC-82/20.....	8
112318.....	36	3000-4.....	30, 31	3090MADC-82/20A.....	8
112321R.....	36	3000-5.....	30, 31	3090MAS.....	8
112352.....	36	3000-B.....	11	3090MB.....	8
112353.....	36	3000-BSP.....	11	3090MBS.....	8
112354.....	36	3000-N.....	11	3090MS.....	8
112355.....	36	3000-S.....	11	3090RK1.....	26, 8
112356.....	36	3000-SP.....	11	3090RK2.....	26, 32
112357.....	36	3000-SSP.....	11	3091MA.....	8
112363.....	36	3000CAP.....	31	3091MB.....	8
112364.....	36	3000TE.....	11	3091MBS.....	8
112365.....	36	3000TE-B.....	11	3091RK1.....	26, 32
112366.....	36	3000TE-BSP.....	11	3091RK2.....	26
113111.....	20	3000TE-S.....	11	3120.....	6
113131.....	20	3000TE-SP.....	11	3120ADJ/XX.....	6
2-3-213.....	36	3000TE-SSP.....	11	3120/xx.....	6
2-3-400-99BPKIT.....	36	3001SQ-B.....	11	3180.....	6
2-400-1500.....	16	3001SQ-BSP.....	11	3180/xx.....	4
2-400-422237F.....	36	3001SQ-N.....	11	325-P.....	34
2-400-422240.....	36	3001SQ-S.....	11	340039.....	33
2-400-422500.....	36	3001SQ-SP.....	11	341131.....	30
2120.....	6	3001SQ-SSP.....	11	341228.....	34
2120/xx.....	6	300GDBSQCB.....	9	341351.....	30

Part #	Page #	Part #	Page #	Part #	Page #
341611	26, 32	4040RD	10	4621	20
341841	34	4040RK1	33	4622	20
341842	34	4040TE	10	4623	20
3533AA	13	4041RD	10	4A-400-1500	16
3533CA	13	4041RK1	33	4A-400-3501	17
3533CC	13	4041RK3	33	4A-400-422209U	36
3534AA	13	4041TE	10	4A-400-422237U	36
3534CA	13	40427SS	35	4A-400-422500	36
3543CA	13	40428SS	35	4A-400-422501	36
3543CC	13	40429SS	35	4A-480-1500	16
3544AA	13	4042RD	10	4A-480-3501	17
3544CA	13	4042RK1	33	4X4-BD-DOOR	37
3544CC	13	4042TE	10	4X4-BDGASKET	37
390777	31	40430SS	35	4X4BDDOORASM	37
390784	31	40431SS	35	5-380-828U501	17
390798	26, 32, 33	40432	35	5-400-422209U	36
390799	26, 32, 33	40435SS	37	5-400-422237U	36
390846	33	40436SS	37	5-400-422240	36
390847	33	40437SS	37	5-400-422500	36
390911 spacer	34	40438SS	37	5-400-422501	36
391862	34	40439SS	37	5-480-1500	16
4-380-828U501	17	40440SS	37	5-480-3501	17
4-400-422209U	36	40441BN	37	5-RF	37
4-400-422237U	36	40442SS	37	5012	20
4-400-422240	36	40443SS	37	5050	20
4-400-422500	36	40444BR	37	5052	20
4-400-422501	36	40445SS	37	5X4-BDDOORASM	37
4-480-1500	16	40453SS	37	6-380-828U501	17
4-480-3501	17	40454SS	37	6-390-393501	36
4-5-6-213	36	40455SS	37	6-400-3501	17
4-6-400-99BPKIT	36	40456SS	37	6-400-422209U	36
400-ALT-AL	23	4111	20	6-400-422237U	36
400-AS-AL	24	4121	20	6-400-422240	36
400-DLT-AL	23	4122	20	6-400-422500	36
400-G-BU	24, 34	4123	20	6-400-422501	36
40022ALTAL	23	4124	20	6-480-1500	16
40022DLTAL	23	4125	20	6-480-3501	17
400GAGFI	24	4126B	20	6-99-400BPKIT	36
400GTTFCB	9	4127	20	600-ALT-AL	23
400GTTFK	9	4129	20	600-DLT-AL	23
400GTTFTK	9	4130	20	6000-10	34
40158ST	37	4134	20	6000-16	26, 8
40263SS	37	4135	20	6000-17	26, 8
40321TF	9	4137	20	6000-18	30
40322TF	9	4139	20	6000-19	30, 34
40394AL	37	4149	20	6000-20	26, 8
40396NY	35	4155	20	6000-23	30
40397AL	35	4157	20	6000-24	30
40398BN	35	4159	20	6000NPHK	26
40402SS	37	4167	20	6400SGK	30

Part #	Page #	Part #	Page #	Part #	Page #
6X4-BDDOORASM.....	37	DB510TI-PXC.....	19	PC5004.....	12
6X4-BDGASKET.....	37	DB510TI-PXP.....	19	PC5005.....	12
8-400-1500.....	16	DB510TI-PXT.....	19	PC5006.....	12
8-400-4222370.....	36	DB510TI-PXV.....	19	PC5007.....	12
8-400-422500.....	36	DB510TI-VXC.....	19	SC5-16-18X2.5P.....	30
8X4-BDDOORASM.....	37	DB510TI-VXP.....	19	SC5-16-18X2.75P.....	30
8X4-BDGASKET.....	37	DB510TI-VXT.....	19	SPRG/L4603.....	30, 31
8X4BD DOOR.....	37	DB6-400-1500.....	16	TDF6.....	21
A2180/xxADJ.....	5	DB6-900-150.....	18	TDF7.....	21
A2180ADJ.....	6	DB6-900-301.....	18	TDF8.....	21
A2182.....	6	DB6-900-501.....	18	TTF3AL.....	22
A3180/xxADJ.....	5	DB600LTA.....	19	TTF3AL-3MT.....	9
A3180ADJ.....	6	DB600TA.....	19	TTF400SP.....	22
AC200TUBE.....	5	DB605LTA.....	19	TTF4AL.....	22
ADS400.....	24	DB610TI-PXP.....	19	TTF4AL-3EMT.....	8, 9
AS156.....	30, 34	DB610TI-PXT.....	19	TTF4AL-3FT.....	9
BDBOLTS.....	37	DB610TI-PXV.....	19	TTF4AL-3MT.....	9
CAL15.....	4	DB610TI-VXP.....	19	TTF4AL-4EMT.....	8, 9
CAL25.....	4	DB610TI-VXT.....	19	TTF4AL-4FT.....	9
DB1000.....	13	DB610TI-VXV.....	19	TTF4AL-4MT.....	9
DB1000-SFI.....	13	DB9000.....	21	TTF4ALHC-3MT.....	9
DB206-1010.....	17	DBCG400.....	15	TTF4ALHC-4MT.....	9
DB206-46-5.....	17, 18, 36	DBCG400-P.....	15		
DB206-810.....	17	DBCG400-PG.....	15		
DB237-23-10.....	17, 36	DBPCB400.....	15		
DB237-46-10.....	17, 36	DBV-WB400.....	14		
DB3-400-1500.....	16	G200BL.....	15		
DB3-400-3501.....	17	G200T.....	14		
DB3-900-150.....	18	G300BL.....	15		
DB3-900-301.....	18	G300T.....	14		
DB3-900-501.....	18	G400BL.....	15		
DB4-400-1500.....	16	G400N.....	14		
DB4-400-3501.....	17	G400T.....	14		
DB4-900-150.....	18	G500T.....	14		
DB4-900-301.....	18	GASKETRETAINER.....	37		
DB4-900-501.....	18	L02BL.....	15		
DB400-206-65.....	36	L02BU.....	14		
DB400-237-610.....	36	L03BL.....	15		
DB5-400-1500.....	16	L03BU.....	14		
DB5-400-3501.....	17	L04BL.....	15		
DB5-900-150.....	18	L04BU.....	14		
DB5-900-301.....	18	L05BU.....	14		
DB5-900-501.....	18	O-RINGAS238.....	30		
DB500LTA.....	19	PC5000.....	12		
DB500TA.....	19	PC5000-002.....	12		
DB500TI.....	19	PC5000AA.....	12		
DB510TI.....	19	PC5000TTTE.....	12		
DB500TI-PXV.....	19	PC5000VV.....	12		
DB500TI-VXV.....	19	PC5001.....	12		
DB510RK.....	19	PC5001-002.....	12		

## Limited Warranty

DIXON VALVE & COUPLING COMPANY, LLC (herein called "Dixon") warrants the products described herein, and manufactured by Dixon to be free from defects in material and workmanship for a period of one (1) year from date of shipment by Dixon under normal use and service. It's sole obligation under this warranty being limited to repairing or replacing, as hereinafter provided, at its option any product found to Dixon's satisfaction to be defective upon examination by it, provided that such product shall be returned for inspection to Dixon's factory within three (3) months after discovery of the defect. The repair or replacement of defective products will be made without charge for parts or labor. This warranty shall not apply to: (a) parts or products not manufactured by Dixon, the warranty of such items being limited to the actual warranty extended to Dixon by its supplier; (b) any product that has been subject to abuse, negligence, accident, or misapplication; (c) any product altered or repaired by others than Dixon; and (d) to normal maintenance services and the replacement of service items (such as washers, gaskets and lubricants) made in connection with such services. To the extent permitted by law, this limited warranty shall extend only to the buyer and any other person reasonably expected to use or consume the goods who is injured in person by any breach of the warranty. No action may be brought against Dixon for an alleged breach of warranty unless such action is instituted within one (1) year from the date the cause of action accrues. This limited warranty shall be construed and enforced to the fullest extent allowable by applicable law.

Other than the obligation of Dixon set forth herein, Dixon disclaims all warranties, express or implied, including but not limited to any implied warranties of merchantability or fitness for a particular purpose, and any other obligation or liability. The foregoing constitutes Dixon's sole obligation with respect to damages, whether direct, incidental or consequential, resulting from the use or performance of the product.

Some products and sizes may be discontinued when stock is depleted, or may require a minimum quantity for ordering.

---

## Limits of Liability

This catalog is intended as a product offering. It is not intended to be a user or technical manual. Information in this catalog is subject to change without notice. All users and distributors of products sold through this catalog should contact Dixon® with questions of use, compatibilities, coupling procedures and life of product. Our full-time engineering and test staff is always available to recommend uses and to assist distributors and users with any questions.



---

## Safety



Safety logos, which appear throughout our catalog, are used as a reminder that the user should carefully review for the appropriateness of the product for the media, application and environment in which it will be used.

NOTE: Because of the health hazards associated with contamination and lead content in drinking water systems, Dixon® couplings, unless otherwise specifically approved, are not recommended for potable water service and should not be used in applications where drinking water will contact the wetted surfaces of the coupling.

Warning: Dixon® products may contain chemicals known to the State of California to cause cancer, birth defects, or other reproduction harm.

---

## Copyright

Copyright © 2019 by Dixon Valve & Coupling, LLC

All rights reserved. This book is copyrighted material. Use, reproduction or copying of it by anyone other than Dixon® is strictly forbidden without its express written consent.

**Dixon®**

ph 877.963.4966

fx 800.283.4966

dixonvalve.com

# DBD518 INDEX

**Dry Bulk  
Products**  
pages 2 - 24

**Dry Bulk  
Replacement  
Parts**  
Pages 25 - 37

**Dry Bulk  
Index**  
pages 38 - 40

## United States

### **Albany, NY**

ph 518.725.0998  
178A Corporate Drive  
Gloversville, NY 12078  
nysales@dixonvalve.com

### **Atlanta, GA**

ph 770.486.9619  
101 T.D.K. Boulevard  
Suite A  
Peachtree City, GA 30269  
gasales@dixonvalve.com

### **Dallas, NC**

ph 704.376.5755  
2925 Chief Court  
Dallas, NC 28034  
ncsales@dixonvalve.com

### **Chestertown, MD**

ph 800.355.1991  
800 High Street  
Chestertown, MD 21620  
sales@dixonvalve.com

### **Chicago, IL**

ph 630.323.4442  
1011 N. Hilltop Drive  
Itasca, IL 60143  
chsales@dixonvalve.com

### **Cleveland, OH**

ph 330.425.3000  
1900 Enterprise Parkway  
Twinsburg, OH 44087  
ohsales@dixonvalve.com

### **Houston, TX**

ph 713.678.4291  
6525 Homestead Road  
Houston, TX 77028  
txsales@dixonvalve.com

### **Kansas City, MO**

ph 816.221.0064  
1244 Saline Street  
N. Kansas City, MO 64116  
kcsales@dixonvalve.com

### **Los Angeles, CA**

ph 909.605.6400  
8840 Flower Road  
Suites 150/160  
Rancho Cucamonga, CA 91730  
casales@dixonvalve.com

### **Portland, OR**

ph 503.289.0400  
2642 North Marine Drive  
Portland, OR 97217  
plsales@dixonvalve.com

### **Salt Lake City, UT**

ph 801.972.1180  
McGillis Ind. Pk. Suite A  
1972 South 4370 West  
Salt Lake City, UT 84104  
utsales@dixonvalve.com

### **Tampa, FL**

ph 813.247.3500  
5120 Adamo Drive  
Suite E  
Tampa, FL 33619  
flsales@dixonvalve.com



*The Right Connection®*

## **Dixon Bayco**

800 High Street  
Chestertown, MD 21620  
Tech Hot Line: 877-582-3569  
ph 410.778.2002 • 800.355.1991  
fx 410.778.4702 • 800.283.4966  
dixonvalve.com

## International

### **Wingfield SA, Australia**

ph 61.8.8202.6000  
fx 61.8.8202.6099

### **Edmonton, Alberta, Canada**

ph 780.469.5444  
fx 780.463.9205

### **Innisfil, Ontario, Canada**

ph 705.436.1125  
fx 705.436.6251

### **Montreal, Quebec, Canada**

ph 514.422.9292  
fx 514.422.0166

### **Preston, England**

ph 44.1772.323529  
fx 44.1772.314664

### **Paris, France**

ph 33.171.841016  
fx 33.171.841019

### **Troisdorf-Spich, Germany**

ph 49.2241.84406.0  
fx 49.2241.8440679

### **Monterrey, Mexico**

ph 52.81.8354.5649  
fx 52.81.8354.8197

### **St. Petersburg, Russia**

ph 7.812.677.5447  
fx 7.812.956.4782

### **Singapore**

ph 65 6232 5272  
fx 65 6232 5270

### **Sharjah, United Arab Emirates**

ph 971.657.41488  
fx 971.657.41484



**GOODYEAR**  
RUBBER PRODUCTS, INC.

📞 **727-342-5088**

You can also email us at  
**GRP@goodyearrubberproducts.com**